



Creating healthy spaces



Window ventilators

Contents

INTRODUCTION

Need for ventilation	3
Brief guide to UK building regulations, part F - ventilation	4
i-Flux® principle: technology self-regulating	5
Overview technical characteristics	6

OVERFRAME FLAP VENTILATORS

Thermally broken

Invisivent® EVO	8
Invisivent® EVO HF	10

Thermally broken and sound absorbing

Invisivent® EVO AK	12
Invisivent® EVO AK Basic	13
Invisivent® EVO AK High	14
Invisivent® EVO AK Ultra	15
Invisivent® EVO AK Extreme	16
Invisivent® EVO AKD (Max)	17
Invisivent® EVO HR	19
Invisivent® EVO HR Basic	20
Invisivent® EVO HR High	21
Invisivent® EVO HR Ultra	22
AKR33-module	23
Invisivent® EVO UT	24
Invisivent® EVO range	26

FLAP VENTILATORS GLAZED-IN/AT TRANSOM

Thermally broken

TC45	28
TC60	30
AR60-THK60	32
AR75	34
AR90-THK90	36
THM90 ^{EVO} /THM90PB ^{EVO} /THM90TR ^{EVO}	38

Thermally broken and sound absorbing

AK80 ^{EVO} - AK80	40
AK80GL	42

Sonovent®	44
Sonovent® Compact	48
Sonovent® I	50
Sonovent® V	52

FLAP VENTILATOR FOR CONSERVATORIES

Oxyvent®	54
----------	----

ACOUSTIC VENTILATOR FOR SLANT ROOFS

Sonovent® D	56
-------------	----

ROLLER SHUTTER FLAP VENTILATOR

Transivent®	58
-------------	----

SLIDING VENTS

THL100 - THL100V	60
T67 - T100 - T130 - T150	62
TL67 - TL100 - TL100 PB	64

SLOTVENTS

Introduction	66
Interior slotvents	67
Exterior slotvents	69
Sonoslot®	71
Sonoslot® Max	72
Slotvent combinations	73

COMBINED VENTILATION AND SUN SHADING OVERFRAME

Fixvent® Mono AK ^{EVO}	74
---------------------------------	----

EPILOGUE

Additional info	76
How to ventilate in an energy-efficient residence?	78
References	79

Note: please contact RENSON® to check availability of the products in your country.

Need for ventilation

Every day, the indoor air is being polluted by its inhabitants (breathing, sweating), through their activities (cooking, showering, heating and smoking), but also by the building itself and its furnishing (radon, volatile organic compounds, paint, detergents,...). Excessive insulation and inadequate ventilation create a dead and stale air which accumulates mites, molds, viruses, bacteria, as well as moisture and harmful chemicals such as CO₂.

A poor indoor climate may cause breathing problems, dry throat, eye irritation, headaches, allergies, impaired concentration, lack of energy, sleepiness, Moreover, excess moisture in the home can cause odors, condensation and mold growth, hence the importance to properly ventilate on a regular basis.

Ventilation: for you and your home!

Many people think that opening the window from time to time is sufficient. However, the effect of opening a window is only temporary and ventilation through open windows is uncontrollable (and therefore wasted energy). In addition, opening the window leads to other problems such as noise, the risk of burglary, the intrusion of insects and so on.

Continuous and controlled ventilation is the only effective method to ensure a healthy indoor climate.

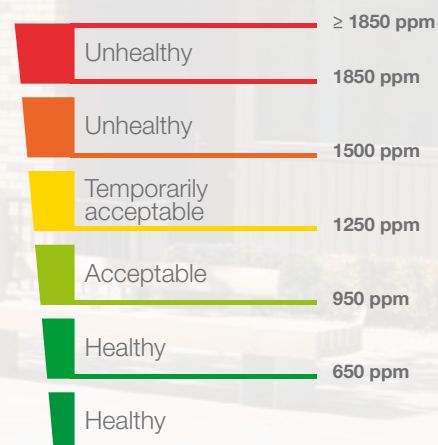

Domestic buildings

New Buildings (with any design air permeability)

Previously ventilation area was shown in free area mm² whereas now it is calculated and shown as Equivalent Area (EA) per mm² as in the table shown below based upon 2 occupants in the main bedroom and a single occupant in all other bedrooms.

total floor area (m ²)	Number of Bedrooms				
	1	2	3	4	5
< 50	35000	40000	50000	60000	65000
51 - 60	35000	40000	50000	60000	65000
61 - 70	45000	45000	50000	60000	65000
71 - 80	50000	50000	50000	60000	65000
81 - 90	55000	60000	60000	60000	65000
91 - 100	65000	65000	65000	65000	65000
> 100	add 7000 mm ² for every additional 10 m ² floor area				

The minimum equivalent area (EA) for habitable rooms is 5000 mm² EA and for any wet room 2500 mm² EA.

Please contact RENSON UK for more information regarding basements, habitable rooms with non opening windows, modular or portable buildings and acoustic needs for buildings.

Existing Buildings

Where renovations are being carried out to an existing building then the background ventilation should not be smaller than originally provided, but it must be at least 5000 mm² EA for habitable rooms and 2500 mm² EA for wet rooms.

Please contact RENSON UK for more information regarding connecting to a conservatory, addition of a wet room or addition of a habitable room.

Non-domestic buildings

New Offices

10 l/s (litres per second) per person of air supply is needed

Existing offices, hotels, ...

- Floor area under 10m² - 2500 mm² EA
- Floor area over 10m² - 250 mm²/m² EA
- Kitchens - 2500 mm² EA
- Bathrooms/showers/WC - 2500 mm² EA per bath, shower or toilet

New schools (according to Building Bulletin 101)

8 l/s (litres per second) per person of air supply is needed.

Unique, self-regulating flap ventilators: innovative and energy-saving



i-Flux® technology

By applying the **i-Flux Technology**, RENSON® can guarantee an optimal comfort and minimize energy loss with its ventilators. **i-Flux Technology** is based upon the following three principles:

1. Airflow independent of wind pressure:

by means of a self-regulating flap in the ventilator that immediately reacts to wind pressure differences, the airflow remains constant (also at high wind forces) and draught is avoided.

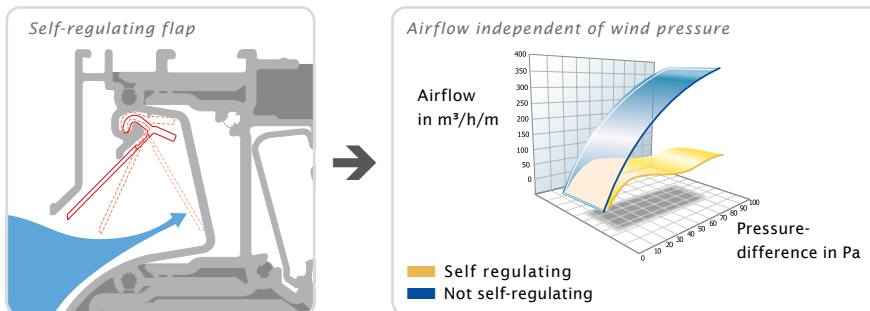

2. Adjustable airflow by means of a manually adjustable interior flap:

the inhabitant can determine himself which level of airflow is required (e.g. in function of the occupancy of the room).

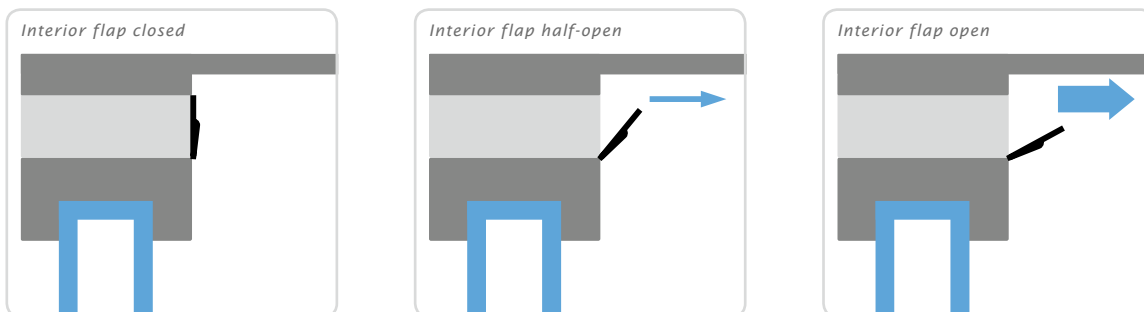

3. Incoming air deflected upwards for an optimal comfort:

by the specific shape of the interior flap, incoming fresh air is deflected upwards, ensuring an optimal spread of the fresh air in the room and hence an optimal comfort for the inhabitants.

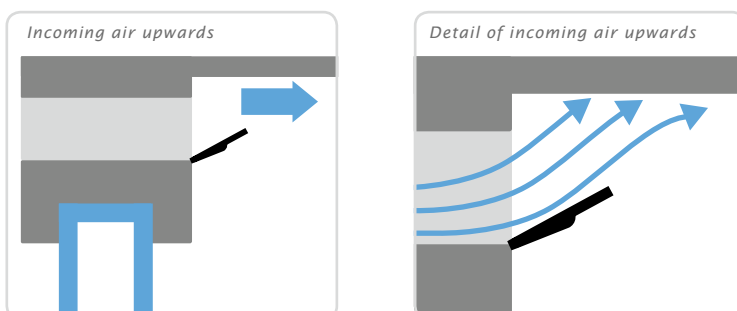

Overview technical characteristics < Introduction

	Page	Equivalent Area (mm ² /m)	Q at 1 Pa (l/s/m)	Q at 1 Pa (m ³ /h/m)	Q at 2 Pa (l/s/m)	Q at 2 Pa (m ³ /h/m)	Q at 10 Pa (l/s/m)	Q at 20 Pa (l/s/m)	Free area (mm ² /m)	Sound reduction D _{new} (C _C) in open position (dB/m)	U-value (W/m ² K)
Overframe flap ventilators											
INVISIVENT ^{EVO}	8	13728	10,8	38,8	14,3	51,3	13,1	14,4	15000	27 (-1;-1)	2,8
INVISIVENT ^{EVO} HF	10	17942	14,1	50,8	18,5	66,6	16,5	18,0	15100	28 (-1;-2)	2,8
INVISIVENT ^{EVO} AK Basic	12	13489	10,6	38,2	15,9	57,2	17,9	16,0	12550	34 (0;-1)	2,0
INVISIVENT ^{EVO} AK High	14	9349	7,3	26,5	11,6	41,7	14,0	11,8	9765	39 (0;-1)	2,2
INVISIVENT ^{EVO} AK Ultra	15	7016	5,5	19,9	9,1	32,8	8,0	9,8	6916	42 (0;-2)	2,2
INVISIVENT ^{EVO} AK Extreme	16	2404	1,9	6,8	2,8	9,9	6,4	9,3	2069	48 (0;-2)	1,7
INVISIVENT ^{EVO} AKD	17	4961	3,9	14,0	5,6	20,3	13,3	19,3	5331	39 (0;-2)	1,2
INVISIVENT ^{EVO} AKD Max	17	1400	1,1	4,0	1,7	6,1	4,0	5,7	1354	47 (-1;-4)	1,2
INVISIVENT ^{EVO} HR Basic	20	13489	10,6	38,2	15,9	57,2	17,9	16,0	12550	34 (0;-1)	2,0
INVISIVENT ^{EVO} HR High	21	9349	7,3	26,5	11,6	41,7	14,0	11,8	9765	39 (0;-1)	2,2
INVISIVENT ^{EVO} HR Ultra	22	7016	5,5	19,9	9,1	32,8	8,0	9,8	6919	42 (0;-2)	2,2
INVISIVENT ^{EVO} AKR33-module	23	11818	9,3	33,4	12,9	46,6	11,6	12,9	13000	33 (-1;-2)	3,6
INVISIVENT ^{EVO} UT	24	10092	7,9	28,6	12,3	44,2	30,7	33,6	9765	39 (0;-1)	2,2
Flap ventilators glazed-in/at transom											
TC45	28	10435	8,2	29,5	11,5	41,4	25,8	36,5	11333	27 (0;0)	4,1
TC60	30	15652	12,3	44,3	17,4	62,6	38,9	55,0	12314	28 (0;0)	3,3
AR60	32	10427	8,2	29,5	11,8	42,3	19,7	23,9	14900	27 (0;0)	4,5
THK60	32	11841	9,3	33,5	13,2	47,5	29,6	41,8	14841	27 (0;0)	4,5
AR75 Small	34	14174	11,1	40,1	15,3	54,9	17,3	14,7	10762	26 (-1;-1)	3,0
AR75 Medium	34	17409	13,7	49,3	18,8	67,5	21,4	18,9	13531	26 (-1;-2)	3,0
AR75 Large	34	19034	15,0	53,9	22,6	81,3	24,5	21,7	16171	26 (-1;-2)	3,0
AR75 Xlarge	34	24301	19,1	68,8	29,0	104,3	31,5	28,0	18431	26 (-1;-1)	3,0
AR90	36	14252	11,2	40,3	15,6	56,2	11,4	9,1	11070	30 (-1;-2)	3,9
THK90	36	14736	11,6	41,7	16,1	57,9	34,5	48,0	14120	28 (0;-1)	3,9
THM90 ^{EVO}	38	11841	9,3	33,5	13,9	50,0	13,5	15,1	11200	26 (0;0)	3,8
THM90PB ^{EVO}	38	11841	9,3	33,5	13,9	50,0	13,5	15,1	11200	26 (0;0)	3,8
THM90TR ^{EVO}	38	11841	9,3	33,5	13,9	50,0	13,5	15,1	11200	26 (0;0)	3,8
AK80 ^{EVO} /1	40	n.p.d.	0,6	2,0	1,1	4,1	3,5	3,7	1280	47 (0;-3)	2,3
AK80 ^{EVO} /2	40	n.p.d.	0,9	3,2	1,7	6,2	5,4	5,8	2080	44 (-1;-4)	2,3
AK80 ^{EVO} /3	40	n.p.d.	1,3	4,7	2,1	7,5	6,6	6,3	2440	41 (-1;-3)	2,3
AK80 ^{EVO} /4	40	n.p.d.	4,1	14,8	6,6	23,6	20,5	19,6	5293	33 (-1;-2)	2,1
AK80/1	40	1488	1,2	4,2	1,6	5,9	3,6	5,0	1280	47 (0;-3)	2,3
AK80/2	40	2163	1,7	6,1	2,5	9,0	5,8	8,4	2080	44 (-1;-4)	2,3
AK80/3	40	2545	2,0	7,2	2,9	10,4	7,1	10,4	2440	41 (-1;-3)	2,3
AK80/4	40	8780	6,9	24,8	9,7	34,9	21,1	29,6	6680	33 (-1;-2)	2,1
AK80GL/1	42	1488	1,2	4,2	1,6	5,9	3,6	5,0	1280	47 (0;-3)	2,3
AK80GL/2	42	2163	1,7	6,1	2,5	9,0	5,8	8,4	2080	44 (-1;-4)	2,3
AK80GL/3	42	2545	2,0	7,2	2,9	10,4	7,1	10,4	2440	41 (-1;-3)	2,3
AK80GL/4	42	8780	6,9	24,8	9,7	34,9	21,1	29,6	6680	33 (-1;-2)	2,1
SONOVENT [®] Small 10	44	17756	14,0	50,2	14,0	50,2	15,3	22,9	10000	46 (-1;-5)	4,5
SONOVENT [®] Small 15	44	29593	23,3	83,7	23,3	83,7	25,6	28,5	11000	41 (-1;-2)	4,5
SONOVENT [®] Small 20	44	31813	25,0	90,0	25,0	90,0	27,5	29,2	18900	40 (-1;-3)	4,5
SONOVENT [®] Small 25	44	33786	26,6	95,6	26,6	95,6	29,2	27,1	22300	37 (-1;-3)	4,5
SONOVENT [®] Medium 10	44	17509	13,8	49,5	13,8	49,5	15,1	n.p.d.	10000	48 (-2;-6)	4,6
SONOVENT [®] Medium 15	44	26511	20,8	75,0	20,8	75,0	22,9	n.p.d.	11000	45 (-2;-6)	4,6
SONOVENT [®] Medium 20	44	33292	26,2	94,2	26,2	94,2	28,8	n.p.d.	18900	43 (0;-3)	4,6
SONOVENT [®] Medium 25	44	34032	26,7	96,3	26,7	96,3	29,4	27,5	22300	39 (-1;-4)	4,6
SONOVENT [®] Large 10	44	16153	12,7	45,7	12,7	45,7	14,0	n.p.d.	10000	50 (-2;-6)	4,6
SONOVENT [®] Large 15	44	25524	20,1	72,2	20,1	72,2	22,1	n.p.d.	11000	49 (-2;-7)	4,6
SONOVENT [®] Large 20	44	32059	25,2	90,7	25,2	90,7	27,7	n.p.d.	18900	44 (-2;-6)	4,6
SONOVENT [®] Large 25	44	33416	26,3	94,5	26,3	94,5	28,9	25,0	22300	41 (-2;-6)	4,6
SONOVENT [®] XLarge 10	44	14427	11,3	40,8	11,3	40,8	12,5	n.p.d.	10000	56 (-2;-6)	4,7
SONOVENT [®] XLarge 15	44	21578	17,0	61,0	17,0	61,0	18,7	n.p.d.	11000	53 (-2;-6)	4,7
SONOVENT [®] XLarge 20	44	31073	24,4	87,9	24,4	87,9	26,9	n.p.d.	18900	46 (-2;-6)	4,7
SONOVENT [®] XLarge 25	44	32676	25,7	92,4	25,7	92,4	28,2	n.p.d.	22300	45 (-2;-6)	4,7
SONOVENT [®] Compact 10	48	15334	12,1	43,4	16,4	58,9	17,3	17,8	9500	36 (0;-1)	6,0
SONOVENT [®] Compact 13	48	19278	15,2	54,5	18,8	67,7	18,8	18,7	12500	35 (0;-1)	6,0
SONOVENT [®] Compact 15	48	24687	19,4	69,8	19,9	71,5	18,6	19,1	15000	33 (0;-1)	6,0
SONOVENT [®] I Small	50	43520	34,2	123,1	48,2	173,5	107,8	152,4	35857	32 (-1;-3)	5,2
SONOVENT [®] I Medium	50	44029	34,6	124,6	48,7	175,3	107,1	150,5	35857	33 (-1;-3)	5,2
SONOVENT [®] I Large	50	43392	34,1	122,8	48,0	172,8	107,3	151,8	35857	35 (-1;-4)	5,2
SONOVENT [®] I Xlarge	50	43138	33,9	122,0	48,0	172,8	107,3	151,8	35857	36 (-1;-4)	5,2
Flap ventilators for conservatories											
Oxyvent [®]	54	15058	11,8	42,6	16,7	60,2	37,4	52,9	19300	27 (-1;-2)	2,8
Acoustic ventilator for slant roofs											
SONOVENT [®] D Small	56	31070	24,4	87,9	28,0	100,8	30,8	34,8	22300	37 (-1;-3)	4,5
SONOVENT [®] D Medium	56	31070	24,4	87,9	28,0	100,8	30,8	34,8	22300	39 (-1;-4)	4,6
SONOVENT [®] D Large	56	31070	24,4	87,9	28,0	100,8	30,8	34,8	22300	41 (-2;-6)	4,6
Roller shutter flap ventilator											
Transivent [®]	58	13748	10,8	38,9	15,2	54,6	20,1	19,9	16368	28 (-1;-2)	3,0
Sliding vents											
THL100	60	16759	13,2	47,4	18,7	67,2	41,6	58,9	16200	22 (0;-1)	3,9
THL100V	60	12770	10,0	36,1	14,2	51,3	32,1	45,5	27950	22 (0;-1)	3,9
T67	62	11224	8,8	31,8	12,7	45,7	28,5	40,2	16330	n.p.d.	n.p.d.
T100	62	17326	13,6	49,0	19,5	70,3	43,8	61,9	25342	n.p.d.	n.p.d.
T130	62	24589	19,3	69,6	27,7	99,8	62,1	87,9	38302	n.p.d.	n.p.d.
T150	62	27992	22,0	79,2	31,9	114,8	71,5	101,0	45592	n.p.d.	n.p.d.
TL67	64	10137	8,0	28,7	11,4	41,4	25,3	36,2	16330	n.p.d.	n.p.d.
TL100	64	14198	11,2	40,2	16,0	57,5	35,8	50,6	25342	n.p.d.	n.p.d.
TL100 PB	64	14198	11,2	40,2	16,0	57,5	35,8	50,6	25342	n.p.d.	n.p.d.
Slotvents											
Sonoslot [®] , 275 mm	71	1273	1,0	3,6	1,4	5,0	3,2	3,3	1256	38 (0;0)	1,4
Sonoslot [®] , 375 mm	71	1607	1,3	4,5	1,7	6,2	4,0	4,2	1885	37 (0;0)	1,4
Sonoslot [®] , 475 mm	71	2121	1,7	6,0	2,3	8,3	5,3	5,6	2513	36 (0;0)	1,4
Sonoslot [®] , 700 mm	71	3181	2,5	9,0	3,4	12,4	8,0	8,4	3769	34 (0;0)	1,4
Sonoslot [®] Max without damping	72	2298	1,8	6,5	2,7	9,7	6,8	6,9	1871	38 (-1;-2)	n.p.d.
Sonoslot [®] Max with damping	72	1555	1,2	4,4	1,9	6,8	5,1	7,6	1871	40 (-1;-2)	n.p.d.
Combined ventilation and sun shading overframe											
Fixvent [®] Mono AK ^{EVO}											

See technical values on page 74-75

Airflow based upon aluminiumsize = 1000 mm (except slotvents)

* not for installation at transom • ** other thickness on request • *** 2000 mm glazed-in installation / 2500 mm installation at transom
n.p.d. : no performances determined • n.a. : not applicable

Self-regulating	i-FLux*	Glass reduction (mm)	Glass thickness (mm)	Finish	Maximum length (mm)	
Overframe flap ventilators						
yes	yes	0	n.p.d.	anodised / RAL / dual color	6000	INVISIVENT [®] EVO
yes	yes	0	n.p.d.	anodised / RAL / dual color	6000	INVISIVENT [®] EVO HF
yes	yes	0	n.p.d.	anodised / RAL / dual color	6000	INVISIVENT [®] EVO AK Basic
yes	yes	0	n.p.d.	anodised / RAL / dual color	6000	INVISIVENT [®] EVO AK High
yes	yes	0	n.p.d.	anodised / RAL / dual color	6000	INVISIVENT [®] EVO AK Ultra
no	no	0	n.p.d.	anodised / RAL / dual color	6000	INVISIVENT [®] EVO AK Extreme
yes	yes	0	n.p.d.	anodised / RAL / dual color	6000	INVISIVENT [®] EVO AKD
yes	yes	0	n.p.d.	anodised / RAL / dual color	6000	INVISIVENT [®] EVO AKD Max
yes	yes	0	n.p.d.	anodised / RAL / dual color	6000	INVISIVENT [®] EVO HR Basic
yes	yes	0	n.p.d.	anodised / RAL / dual color	6000	INVISIVENT [®] EVO HR High
yes	yes	0	n.p.d.	anodised / RAL / dual color	6000	INVISIVENT [®] EVO HR Ultra
yes	yes	0	n.p.d.	anodised / RAL / dual color	6000	INVISIVENT [®] EVO AKR33-module
as from 10 Pa	yes	0	n.p.d.	anodised / RAL / dual color	6000	INVISIVENT [®] EVO UT
Flap ventilators glazed-in/at transom						
no	no	45	20/24/28	anodised / RAL / dual color	2500	TC45
no	no	60	20/24/28	anodised / RAL / dual color	2500	TC60
yes	yes	60	20/24/28	anodised / RAL / dual color	2500	AR60
no	no	60	20/24/28	anodised / RAL / dual color	2500	THK60
yes	no	75/77	20/24/28/32/36*/40*/44*	anodised / RAL / dual color	2500	AR75 Small
yes	no	75/77	20/24/28/32/36*/40*/44*	anodised / RAL / dual color	2500	AR75 Medium
yes	no	75/77	20/24/28/32/36*/40*/44*	anodised / RAL / dual color	2500	AR75 Large
yes	no	75/77	20/24/28/32/36*	anodised / RAL / dual color	2500	AR75 Xlarge
yes	no	90	20/24/28	anodised / RAL / dual color	2500 (2000 mm for motorised control)	AR90
no	no	90	20/24/28	anodised / RAL / dual color	2500 (2000 mm for motorised control)	THK90
yes	no	90	20/24/28/33	anodised / RAL / dual color	2500 (2000 mm for motorised control)	THM90 ^{EVO}
yes	no	90	20/24/28	anodised / RAL / dual color	2500 (2000 mm for motorised control)	THM90PB ^{EVO}
yes	no	90	20/24	anodised / RAL / dual color	2500 (2000 mm for motorised control)	THM90TR ^{EVO}
as from 8 Pa	yes	n.a.	n.p.d.	anodised / RAL / dual color	2000 (1250 mm for cord control)	AK80 ^{EVO} /1
as from 8 Pa	yes	n.a.	n.p.d.	anodised / RAL / dual color	2000 (1250 mm for cord control)	AK80 ^{EVO} /2
as from 8 Pa	yes	n.a.	n.p.d.	anodised / RAL / dual color	2000 (1250 mm for cord control)	AK80 ^{EVO} /3
as from 8 Pa	yes	n.a.	n.p.d.	anodised / RAL / dual color	2000 (1250 mm for cord control)	AK80 ^{EVO} /4
no	no	n.a.	n.p.d.	anodised / RAL / dual color	2000 (1250 mm for cord control)	AK80/1
no	no	n.a.	n.p.d.	anodised / RAL / dual color	2000 (1250 mm for cord control)	AK80/2
no	no	n.a.	n.p.d.	anodised / RAL / dual color	2000 (1250 mm for cord control)	AK80/3
no	no	n.a.	n.p.d.	anodised / RAL / dual color	2000 (1250 mm for cord control)	AK80/4
no	no	108	20/24/28/32/36	anodised / RAL / dual color	2000 (1250 mm for cord control)	AK80GL/1
no	no	108	20/24/28/32/36	anodised / RAL / dual color	2000 (1250 mm for cord control)	AK80GL/2
no	no	108	20/24/28/32/36	anodised / RAL / dual color	2000 (1250 mm for cord control)	AK80GL/3
no	no	108	20/24/28/32/36	anodised / RAL / dual color	2000 (1250 mm for cord control)	AK80GL/4
yes	no	130/135	20/24/28/32**	RAL / dual color	2000/2500***	SONOVENT [®] Small 10
yes	no	130/135	20/24/28/32**	RAL / dual color	2000/2500***	SONOVENT [®] Small 15
yes	no	130/135	20/24/28/32**	RAL / dual color	2000/2500***	SONOVENT [®] Small 20
yes	no	130/135	20/24/28/32**	RAL / dual color	2000/2500***	SONOVENT [®] Small 25
yes	no	130/135	20/24/28/32**	RAL / dual color	2000/2500***	SONOVENT [®] Medium 10
yes	no	130/135	20/24/28/32**	RAL / dual color	2000/2500***	SONOVENT [®] Medium 15
yes	no	130/135	20/24/28/32**	RAL / dual color	2000/2500***	SONOVENT [®] Medium 20
yes	no	130/135	20/24/28/32**	RAL / dual color	2000/2500***	SONOVENT [®] Medium 25
yes	no	130/135	20/24/28/32**	RAL / dual color	2000/2500***	SONOVENT [®] Large 10
yes	no	130/135	20/24/28/32**	RAL / dual color	2000/2500***	SONOVENT [®] Large 15
yes	no	130/135	20/24/28/32**	RAL / dual color	2000/2500***	SONOVENT [®] Large 20
yes	no	130/135	20/24/28/32**	RAL / dual color	2000/2500***	SONOVENT [®] Large 25
yes	no	130/135	20/24/28/32**	RAL / dual color	2000/2500***	SONOVENT [®] XLarge 10
yes	no	130/135	20/24/28/32**	RAL / dual color	2000/2500***	SONOVENT [®] XLarge 15
yes	no	130/135	20/24/28/32**	RAL / dual color	2000/2500***	SONOVENT [®] XLarge 20
yes	no	130/135	20/24/28/32**	RAL / dual color	2000/2500***	SONOVENT [®] XLarge 25
yes	no	78	20/24/28/32/36	RAL / dual color	2000/2500***	SONOVENT [®] Compact 10
yes	no	78	20/24/28/32/36	RAL / dual color	2000/2500***	SONOVENT [®] Compact 13
yes	no	78	20/24/28/32/36	RAL / dual color	2000/2500***	SONOVENT [®] Compact 15
no	no	130/135	20/24/28/32**	RAL / dual color	2000/2500***	SONOVENT [®] I Small
no	no	130/135	20/24/28/32**	RAL / dual color	2000/2500***	SONOVENT [®] I Medium
no	no	130/135	20/24/28/32**	RAL / dual color	2000/2500***	SONOVENT [®] I Large
no	no	130/135	20/24/28/32**	RAL / dual color	2000/2500***	SONOVENT [®] I Xlarge
Flap ventilators for conservatories						
no	no	210	28 - 86 (by steps of 2 mm)	RAL / dual color	1500	Oxyvent [®]
Acoustic ventilator for slant roofs						
yes	no	n.a.	n.a.	RAL / dual color	1000	SONOVENT [®] D Small
yes	no	n.a.	n.a.	RAL / dual color	1000	SONOVENT [®] D Medium
yes	no	n.a.	n.a.	RAL / dual color	1000	SONOVENT [®] D Large
Roller shutter flap ventilator						
yes	yes	n.a.	n.a.	anodised / RAL	2200 (1500 mm for cord control)	Transivent [®]
Sliding vents						
no	no	129	15*/20/24/28	anodised / RAL / dual color	3500	THL100
no	no	129	15*/20/24/28	anodised / RAL / dual color	3500	THL100V
no	no	n.a.	n.a.	anodised / RAL / dual color	3500	T67
no	no	n.a.	n.a.	anodised / RAL / dual color	3500	T100
no	no	n.a.	n.a.	anodised / RAL / dual color	3500	T130
no	no	n.a.	n.a.	anodised / RAL / dual color	3500	T150
no	no	98	20	anodised / RAL / dual color	3500	TL67
no	no	129	4/20/24	anodised / RAL / dual color	3500	TL100
no	no	129	20	anodised / RAL / dual color	3500	TL100 PB
Slotvents						
yes	yes	n.a.	n.a.	anodised / Renson standard WHITE, 9005, 1247	275	Sonoslot [®] , 275 mm
yes	yes	n.a.	n.a.	anodised / Renson standard WHITE, 9005, 1247	375	Sonoslot [®] , 375 mm
yes	yes	n.a.	n.a.	anodised / Renson standard WHITE, 9005, 1247	475	Sonoslot [®] , 475 mm
yes	yes	n.a.	n.a.	anodised / Renson standard WHITE, 9005, 1247	700	Sonoslot [®] , 700 mm
yes	no	n.a.	n.a.	Renson standard WHITE / RAL 1247	700	Sonoslot [®] Max without damping
yes	no	n.a.	n.a.	Renson standard WHITE / RAL 1247	700	Sonoslot [®] Max with damping
Combined ventilation and sun shading overframe						
Fixvent [®] Mono AK ^{EVO}						

See technical values on page 74-75

Invisivent® EVO < Overframe flap ventilators

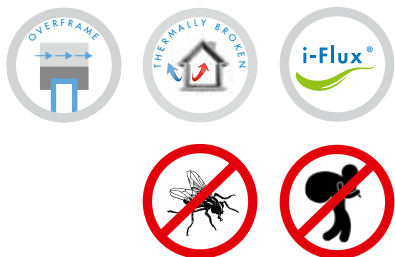

The most discrete, self-regulating overframe flap ventilator

With the Invisivent^{EVO}, RENSON has developed the most discrete self-regulating window ventilator in the world that combines a healthy living comfort with a maximum visual comfort.

Installation on top of the window frame

The Invisivent^{EVO} is a thermally broken window ventilator that is installed on top of the aluminium, timber or PVC window frame. This almost invisible installation guarantees maximum light penetration as the glass size is not reduced.

Thermally broken

No cold air transfer from outside to inside.

i-Flux®

Thanks to its self-regulating flap, the Invisivent^{EVO} ensures the supply of fresh and healthy air without draughts. Moreover, the interior profile deflects the incoming air upwards, causing an optimal spread of fresh air in the room.

Insect mesh

Burglar proof

The Invisivent^{EVO} range meets the requirements of burglary resistance class 2 according to standard prEN 1627 to 1630, and therefore suits to be used on a window class WK2.



Section detail

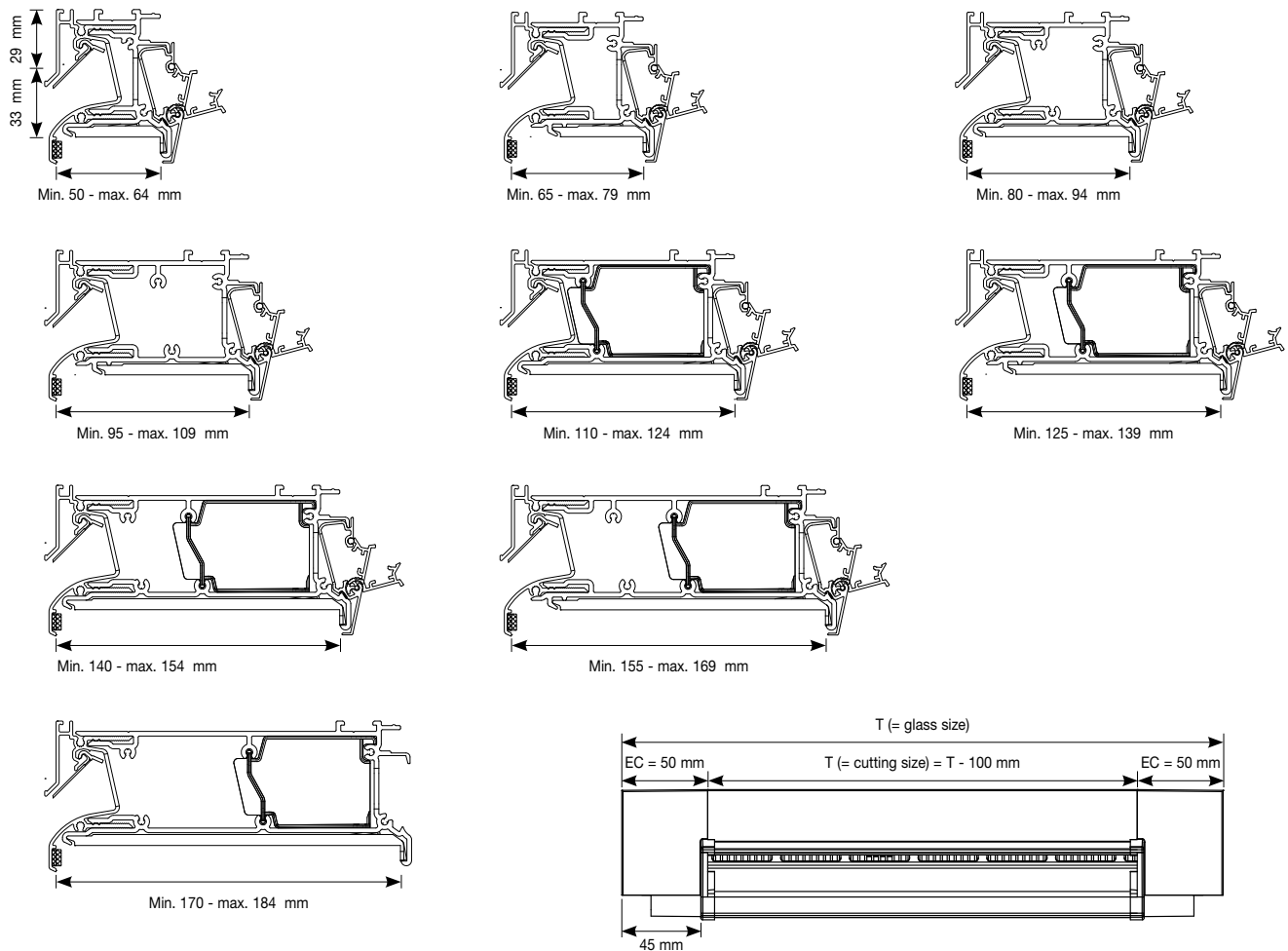

Technical characteristics	Invisivent® EVO
Airflow	
Equivalent area	13728 mm ² /m
Q at 1 Pa	10,8 l/s/m
Q at 1 Pa	38,8 m ³ /h/m
Q at 2 Pa	14,3 l/s/m
Q at 10 Pa	13,1 l/s/m
Q at 20 Pa	14,4 l/s/m
Comfort	
Sound reduction D _{n,e,w} (C;C _{tr})	
- in open position	27 (-1;-1) dB
- in closed position	49 (-2;-4) dB
Technical characteristics	
Controllable internal flap	6 stepped positions
Control options internal flap	Manual, cord, rod, motor
U value	2,8 W/m ² K
Air leakage at 50 Pa	<15% (in closed position)
Watertightness in closed position, up to	650 Pa
Watertightness in open position, up to	50 Pa
Dimensions	
Glass reduction	0 mm
Height	62 mm
Depths window frame	50 up to 184 mm (or more upon request)
Max. length	6000 mm



Invisivent® EVO HF < Overframe flap ventilators

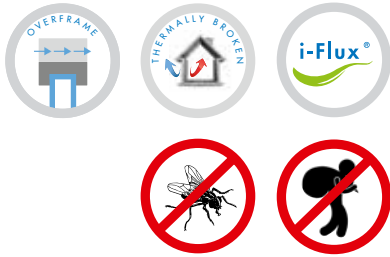

The most discrete, self-regulating overframe flap ventilator with higher airflow

The Invisivent^{EVO} HF delivers 30% more airflow than the regular Invisivent^{EVO}. This version of the Invisivent^{EVO} has been specifically developed for use in spaces with small windows where sufficient airflow must be achieved, and is ideal for ensuring sufficient fresh air in rooms with high occupancy such as classrooms. In closed position there is no visual difference between the Invisivent^{EVO} HF and Invisivent^{EVO}, so both models can be used in the same building.



Installation on top of the window frame

The Invisivent^{EVO} HF is a thermally broken window ventilator that is installed on top of the aluminium, timber or PVC window frame. This almost invisible installation guarantees maximum light penetration as the glass size is not reduced.

30% more airflow than the regular Invisivent® EVO

Thermally broken

No cold air transfer from outside to inside.

i-Flux®

Thanks to its self-regulating flap, the Invisivent^{EVO} HF ensures the supply of fresh and healthy air without draughts. Moreover, the interior profile deflects the incoming air upwards, causing an optimal spread of fresh air in the room.

Insect mesh

Burglar proof

The Invisivent^{EVO} range meets the requirements of burglary resistance class 2 according to standard prEN 1627 to 1630, and therefore suits to be used on a window class WK2.



Section detail

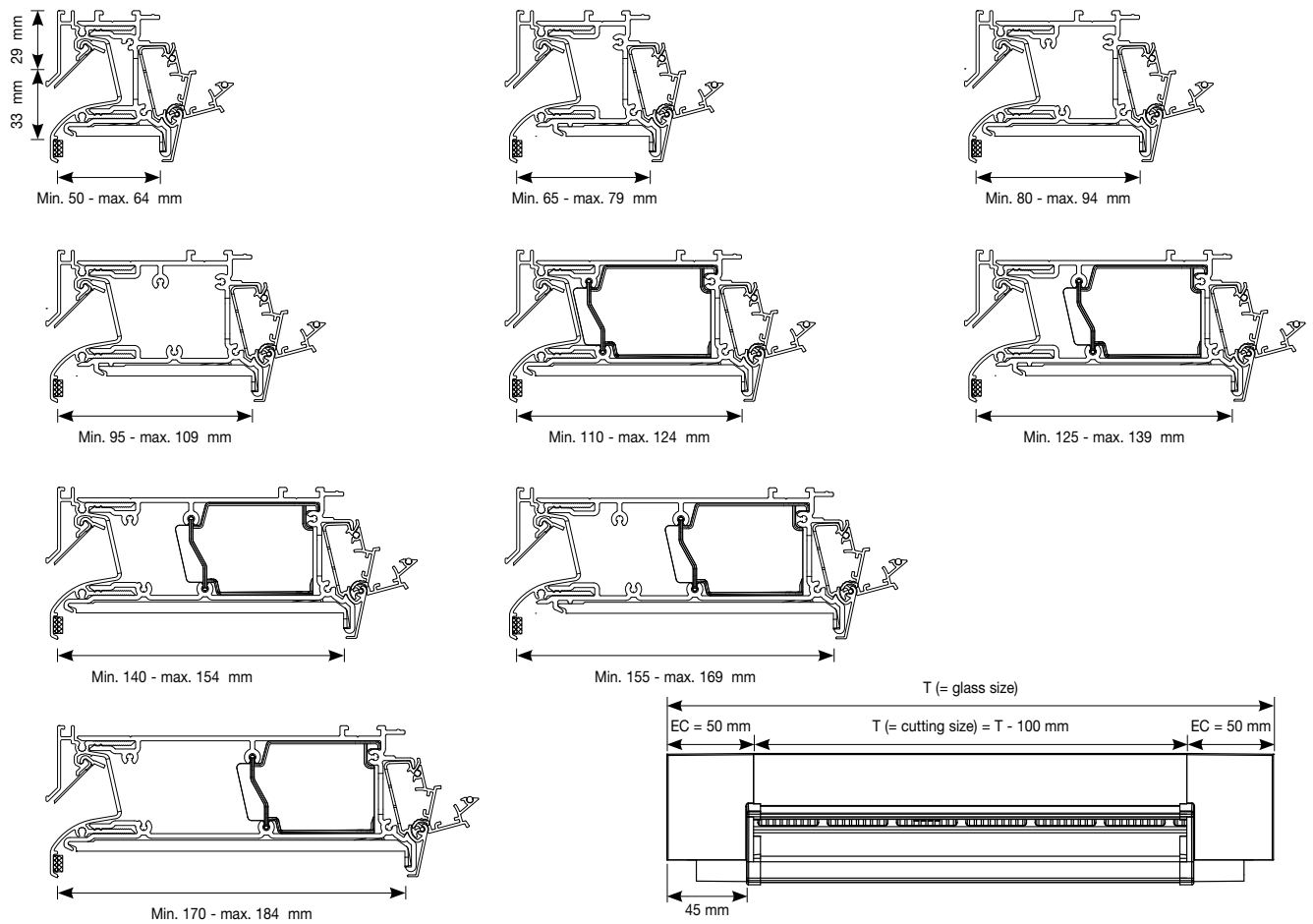

Technical characteristics	Invisivent® EVO HF
Airflow	
Equivalent area	17942 mm ² /m
Q at 1 Pa	14,1 l/s/m
Q at 1 Pa	50,8 m ³ /h/m
Q at 2 Pa	18,5 l/s/m
Q at 10 Pa	16,5 l/s/m
Q at 20 Pa	18,0 l/s/m
Comfort	
Sound reduction D _{n,e,w} (C;C _{tr})	
- in open position	28 (-1;-2) dB
- in closed position	49 (-2;-4) dB
Technical characteristics	
Controllable internal flap	5 stepped positions
Control options internal flap	Manual, cord, rod, motor
U value	2,8 W/m ² K
Air leakage at 50 Pa	<15% (in closed position)
Watertightness in closed position, up to	900 Pa
Watertightness in open position, up to	150 Pa
Dimensions	
Glass reduction	0 mm
Height	62 mm
Depths window frame	50 up to 184 mm (or more upon request)
Max. length	6000 mm



Invisivent® EVO AK < Acoustic overframe flap ventilators

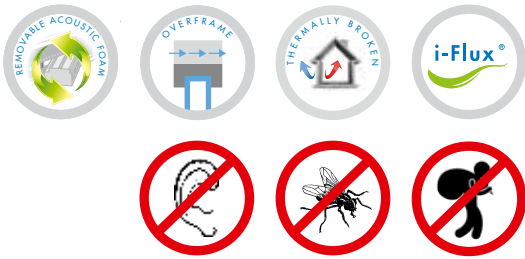

The most discrete, self-regulating and sound-absorbing overframe flap ventilator

The Invisivent^{EVO} AK is the acoustic version of the Invisivent^{EVO}. Four different Invisivent^{EVO} AK versions are available (Basic, High, Ultra or Extreme), each representing a different level of sound reduction. For each specific window frame depth, a different PVC profile is used (and special extension profiles are used for some window frame depths) in order to make the Invisivent^{EVO} AK fit perfectly to the window profile.

Window depth < 110 mm: Invisivent^{EVO} AK Basic + special extension profile
(>110 mm, an adapted PVC interior profile is used)

Window depth < 140 mm: Invisivent^{EVO} AK High / Ultra / Extreme + special extension profile
(>140 mm, an adapted PVC interior profile is used)



Installation on top of the window frame

The Invisivent^{EVO} AK is a thermally broken window ventilator that is installed on top of the aluminium, timber or PVC window frame. This almost invisible installation guarantees maximum light penetration as the glass size is not reduced.

Thermally broken

No cold air transfer from outside to inside.

i-Flux®

Thanks to its self-regulating flap, the Invisivent^{EVO} AK ensures the supply of fresh and healthy air without draughts (Invisivent^{EVO} AK Extreme is not self-regulating). Moreover, the interior profile deflects the incoming air upwards, causing an optimal spread of fresh air in the room.

Sound absorbing

In open position: Invisivent^{EVO} AK Basic: 34 (0;-1) dB
Invisivent^{EVO} AK High: 39 (0;-1) dB
Invisivent^{EVO} AK Ultra: 42 (0;-2) dB
Invisivent^{EVO} AK Extreme: 48 (0;-2) dB

Removable acoustic foam

Insect mesh

Burglar proof

The Invisivent^{EVO} range meets the requirements of burglary resistance class 2 according to standard prEN 1627 to 1630, and therefore suits to be used on a window class WK2.



Section detail Invisivent® EVO AK BASIC

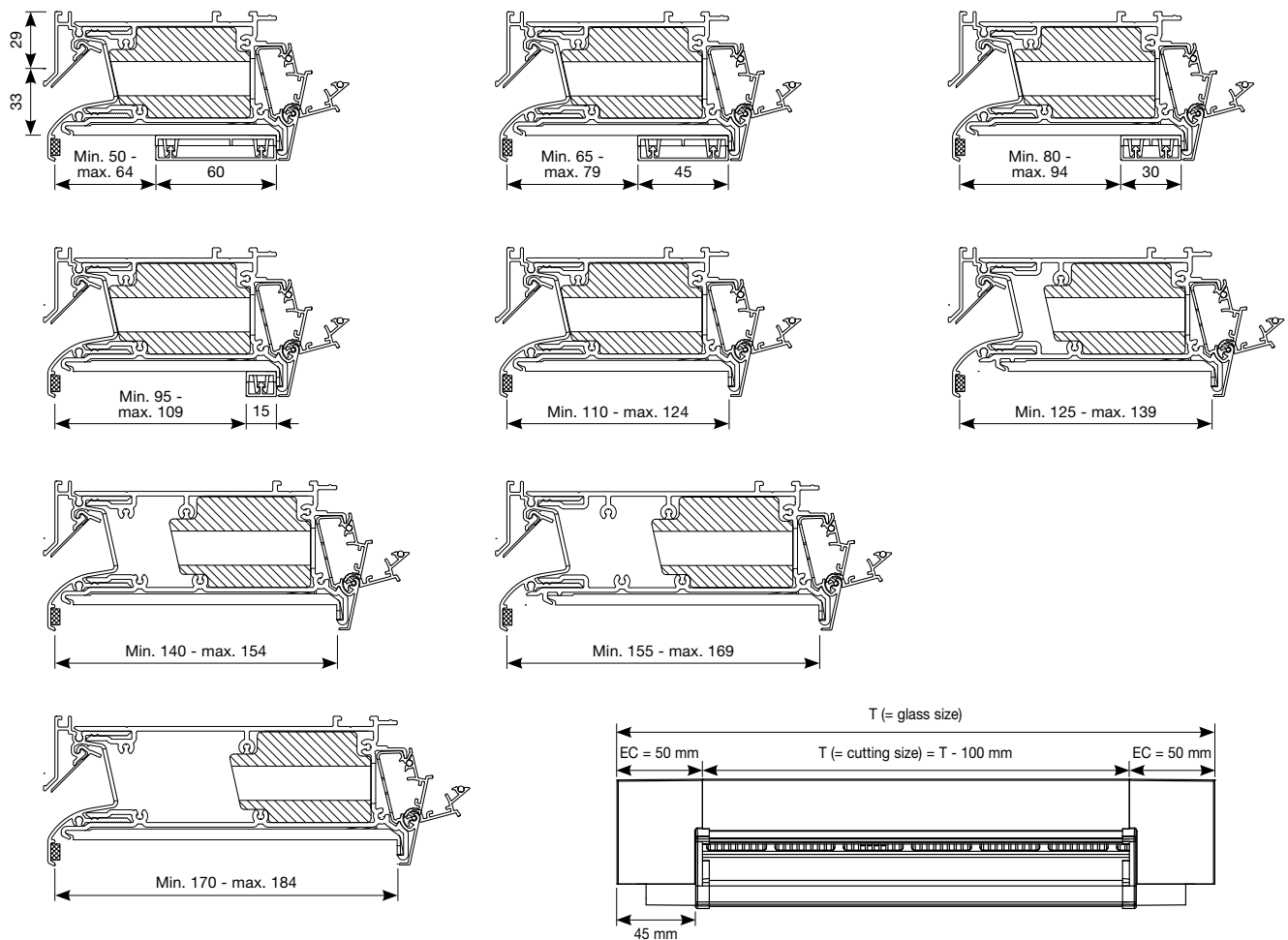

Technical characteristics	Invisivent® EVO AK Basic
Airflow	
Equivalent area	13489 mm ² /m
Q at 1 Pa	10,6 l/s/m
Q at 1 Pa	38,2 m ² /h/m
Q at 2 Pa	15,9 l/s/m
Q at 10 Pa	17,9 l/s/m
Q at 20 Pa	16,0 l/s/m
Comfort	
Sound reduction D _{n,e,w} (C;C _{tr})	
- in open position	34 (0;-1) dB
- in closed position	57 (-1;-4) dB
Technical characteristics	
Controllable internal flap	5 stepped positions
Control options internal flap	Manual, cord, rod, motor
U value	2,0 W/m ² K
Air leakage at 50 Pa	<15% (in closed position)
Watertightness in closed position, up to	900 Pa
Watertightness in open position, up to	150 Pa
Dimensions	
Glass reduction	0 mm
Height	62 mm
Depths window frame	50 up to 184 mm (or more upon request)
Max. length	6000 mm



Invisivent® EVO AK High < Acoustic overframe flap ventilators

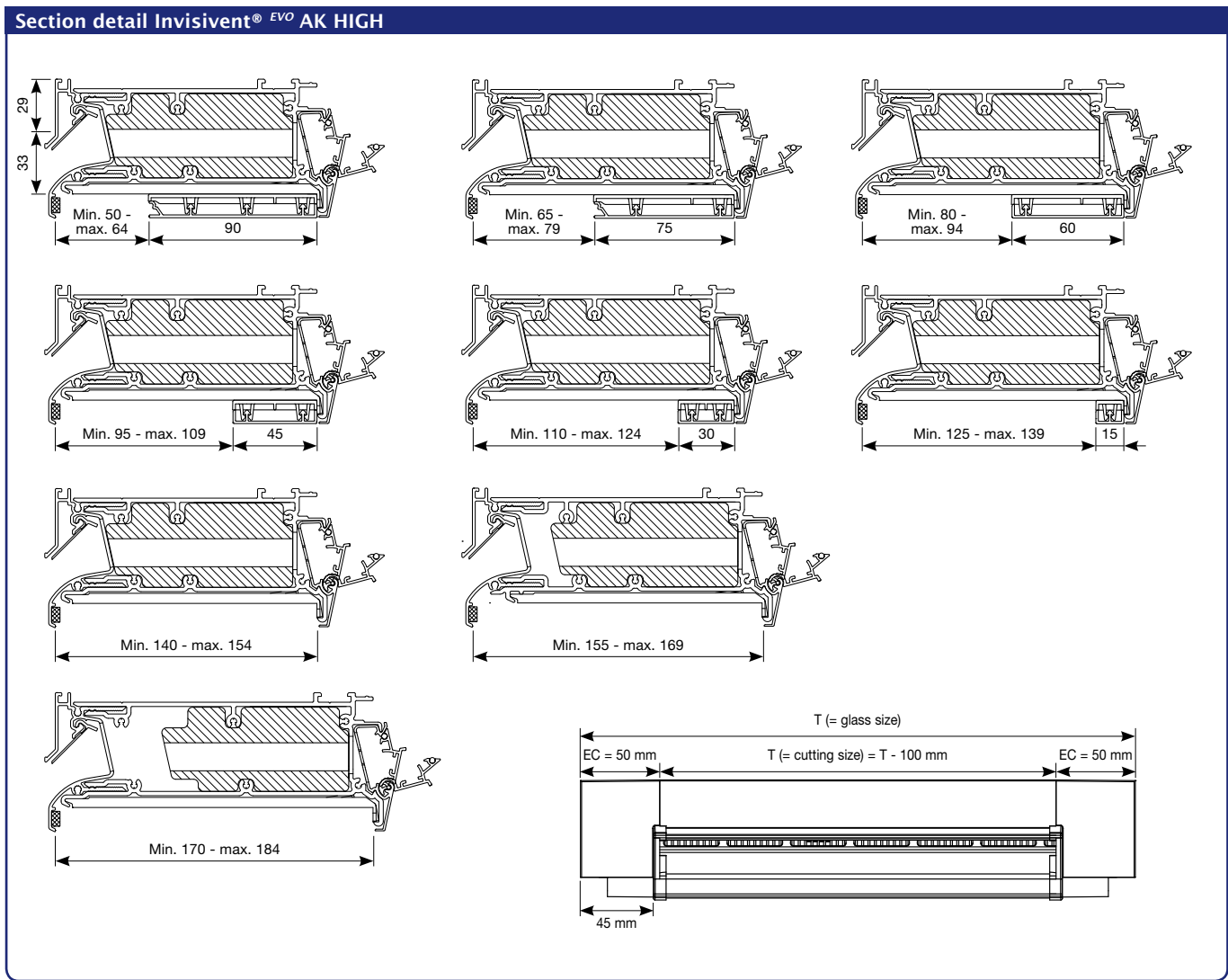

Technical characteristics	Invisivent® EVO AK High
Airflow	
Equivalent area	9349 mm ² /m
Q at 1 Pa	7,3 l/s/m
Q at 1 Pa	26,5 m ³ /h/m
Q at 2 Pa	11,6 l/s/m
Q at 10 Pa	14,0 l/s/m
Q at 20 Pa	11,8 l/s/m
Comfort	
Sound reduction D _{n,e,w} (C;C _{tr})	
- in open position	39 (0;-1) dB
- in closed position	62 (-2;-6) dB
Technical characteristics	
Controllable internal flap	5 stepped positions
Control options internal flap	Manual, cord, rod, motor
U value	2,2 W/m ² K
Air leakage at 50 Pa	<15% (in closed position)
Watertightness in closed position, up to	900 Pa
Watertightness in open position, up to	150 Pa
Dimensions	
Glass reduction	0 mm
Height	62 mm
Depths window frame	50 up to 184 mm (or more upon request)
Max. length	6000 mm

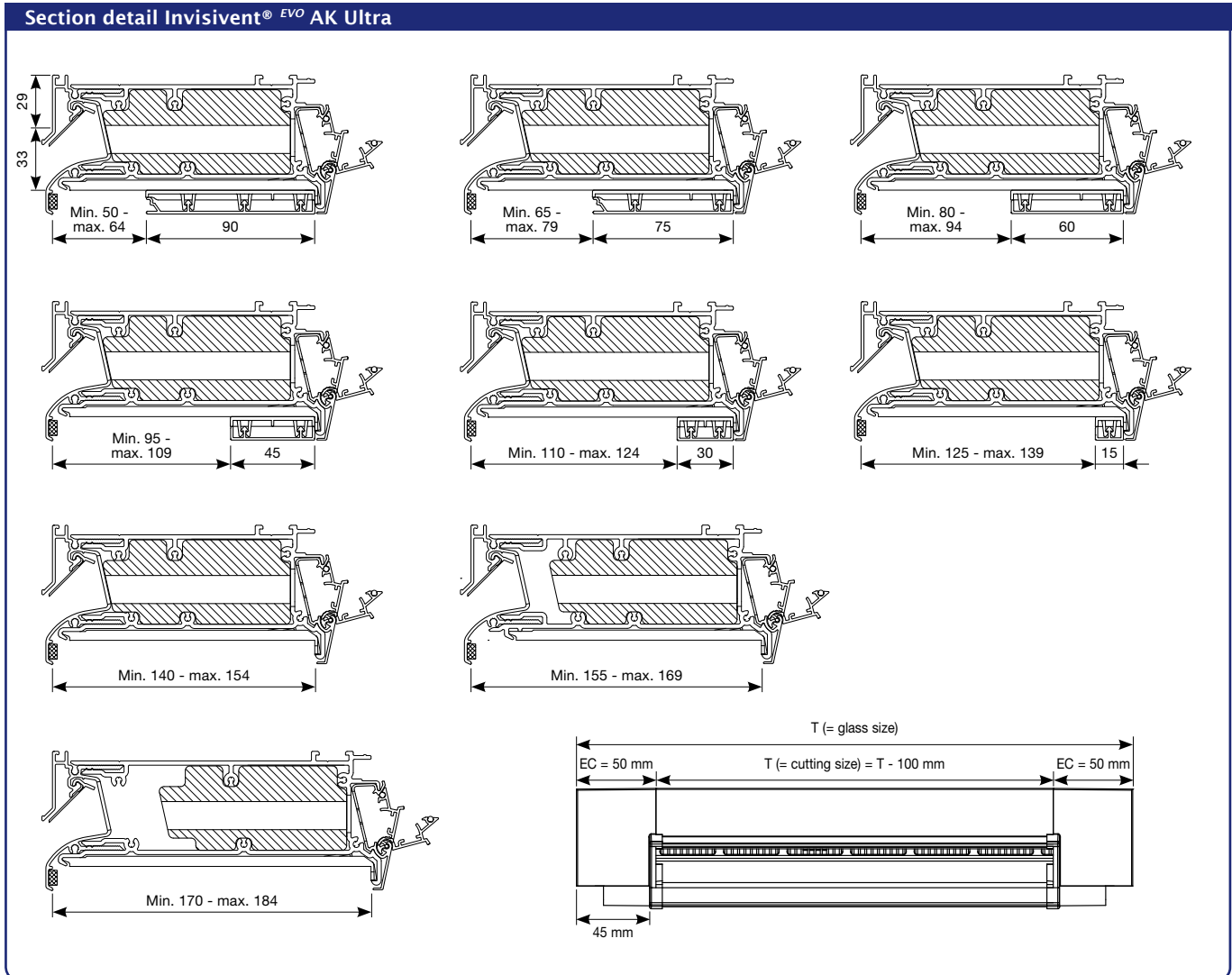

Technical characteristics	Invisivent® EVO AK Ultra
Airflow	
Equivalent area	7016 mm ² /m
Q at 1 Pa	5,5 l/s/m
Q at 1 Pa	19,9 m ³ /h/m
Q at 2 Pa	9,1 l/s/m
Q at 10 Pa	8,0 l/s/m
Q at 20 Pa	9,8 l/s/m
Comfort	
Sound reduction $D_{n,e,w}$ (C;C _{tr})	
- in open position	42 (0;-2) dB
- in closed position	64 (-1;-4) dB
Technical characteristics	
Controllable internal flap	5 stepped positions
Control options internal flap	Manual, cord, rod, motor
U value	2,2 W/m ² K
Air leakage at 50 Pa	<15% (in closed position)
Watertightness in closed position, up to	900 Pa
Watertightness in open position, up to	150 Pa
Dimensions	
Glass reduction	0 mm
Height	62 mm
Depths window frame	50 up to 184 mm (or more upon request)
Max. length	6000 mm



Invisivent® EVO AK Extreme < Acoustic overframe flap ventilators

Section detail Invisivent® EVO AK Extreme

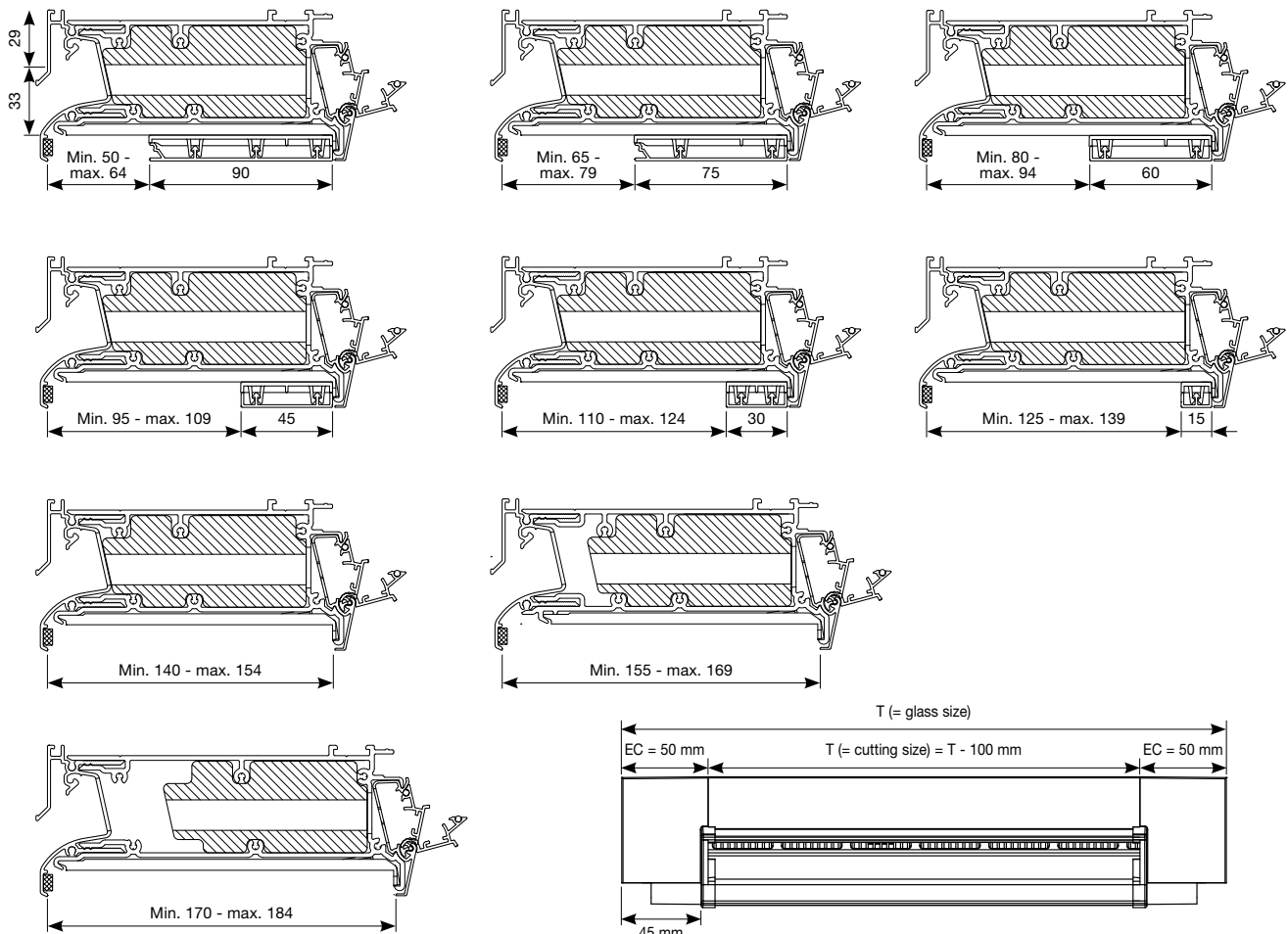

Attention: Invisivent® EVO AK Extreme is visually identical to the Invisivent® EVO AK High and Invisivent® EVO UT, but is not self-regulating!



Technical characteristics	Invisivent® EVO AK Extreme
Airflow	
Equivalent area	2404 mm ² /m
Q at 1 Pa	1,9 l/s/m
Q at 1 Pa	6,8 m ³ /h/m
Q at 2 Pa	2,8 l/s/m
Q at 10 Pa	6,4 l/s/m
Q at 20 Pa	9,3 l/s/m
Comfort	
Sound reduction $D_{n,e,w}$ ($C; C_{tr}$)	
- in open position	48 (0;-2) dB
- in closed position	64 (-4;-11) dB
Technical characteristics	
Controllable internal flap	5 stepped positions
Control options internal flap	Manual, cord, rod, motor
U value	1,7 W/m ² K
Air leakage at 50 Pa	<15% (in closed position)
Watertightness in closed position, up to	900 Pa
Watertightness in open position, up to	150 Pa
Dimensions	
Glass reduction	0 mm
Height	62 mm
Depths window frame	50 up to 184 mm (or more upon request)
Max. length	6000 mm

Acoustic overframe flap ventilators > Invisivent® EVO AKD (Max)

The most discrete, self-regulating and superior sound absorbing overframe ventilator

The Invisivent^{EVO} AKD (Max) is a sound absorbing, self-regulating and thermally broken window ventilator that is installed on top of the window frame. This acoustic version of the Invisivent^{EVO} combines a healthy living comfort with a maximum visual comfort, without losing any acoustic comfort.

Compared to the Invisivent^{EVO} AK-series, this Invisivent^{EVO} AKD (Max) has a much better acoustic performance thanks to the extra outer profile. Two different types are available: the Invisivent^{EVO} AKD and the Invisivent^{EVO} AKD Max - the latter with an even better acoustic performance than the first.

For each specific window frame depth, a different PVC profile is used (and special extension profiles are used for some window frame depths) in order to make the Invisivent^{EVO} AKD (Max) fit perfectly to the window profile.

Installation on top of the window frame

The Invisivent^{EVO} AKD (Max) is a thermally broken window ventilator that is installed on top of the aluminium, timber or PVC window frame. This almost invisible installation guarantees maximum light penetration as the glass size is not reduced.

Thermally broken

No cold air transfer from outside to inside.

i-Flux®

Thanks to its self-regulating flap, the Invisivent^{EVO} AKD (Max) ensures the supply of fresh and healthy air without draughts. Moreover, the interior profile deflects the incoming air upwards, causing an optimal spread of fresh air in the room.

Sound absorbing

Invisivent^{EVO} AKD: 39 (0;-2) dB in open position

Invisivent^{EVO} AKD Max: 47 (-1;-4) dB in open position

Removable acoustic foam

Insect mesh

Burglar proof

The Invisivent^{EVO} range meets the requirements of burglary resistance class 2 according to standard prEN 1627 to 1630, and therefore suits to be used on a window class WK2.



Invisivent® EVO AKD (Max) < Acoustic overframe flap ventilators

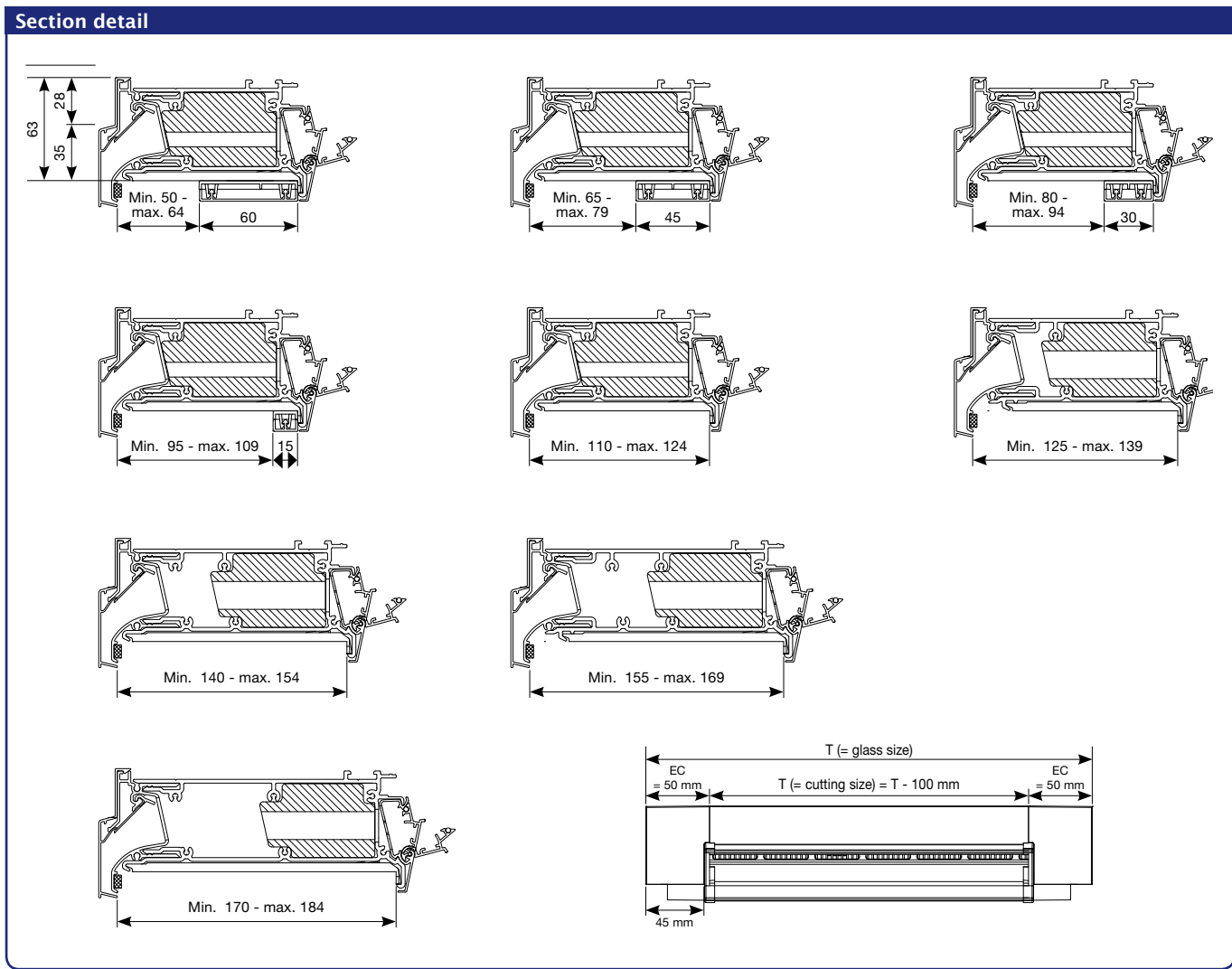

Technical characteristics	Invisivent® EVO AKD	Invisivent® EVO AKD-Max
Airflow		
Equivalent area	4961 mm ² /m	1400 mm ² /m
Q at 1 Pa	3,9 l/s/m	1,1 l/s/m
Q at 1 Pa	14,0 m ³ /h/m	4,0 m ³ /h/m
Q at 2 Pa	5,6 l/s/m	1,7 l/s/m
Q at 10 Pa	13,3 l/s/m	4,0 l/s/m
Q at 20 Pa	19,3 l/s/m	5,7 l/s/m
Comfort		
Sound reduction $D_{n,e,w} (C; C_{tr})$		
- in open position	39 (0;-2) dB	47 (-1;-4) dB
- in closed position	60 (-1;-4) dB	63 (-1;-4) dB
Technical characteristics		
Controllable internal flap	5 stepped positions	
Control options internal flap	Manual, cord, rod, motor	
U value	1,2 W/m ² K (as from window depth 140 mm: 1,0 W/m ² K)	
Air leakage at 50 Pa	<15% (in closed position)	
Watertightness in closed position, up to	900 Pa	
Watertightness in open position, up to	150 Pa	
Dimensions		
Glass reduction	0 mm	
Height	63 mm	
Depths window frame	50 up to 184 mm (or more upon request)	
Max. length	6000 mm	

Acoustic overframe flap ventilators > Invisivent® EVO HR

The most discrete, self-regulating and sound-absorbing overframe flap ventilator for high rise applications

The new Invisivent^{EVO} HR provides the ideal solution for wind-impacted applications such as high-rise buildings and apartment buildings on the coast.

The Invisivent^{EVO} HR contains acoustic material, that muffles external noises as much as possible (e.g. wind, seagulls, traffic), which increases user comfort. The presence of various types of sound damping foam in the inside profile provides 3 possible levels of sound insulation (Basic, High or Ultra). In addition to that, the rain cap, which is mounted as standard, ensures perfect water-resistance in even the most extreme conditions. Extra mounting screws and clips guarantee satisfactory stability and sturdiness of the entire window.

The unique Invisivent^{EVO} HR combines its functionality with maximum respect for the architecture since it can be positioned on the window frame, behind the wall.

Ideal for wind impacted applications (coast and high rise building situations)

Installation on top of the window frame

The Invisivent^{EVO} HR is a thermally broken window ventilator that is installed on top of the aluminium, timber or PVC window frame. This almost invisible installation guarantees maximum light penetration as the glass size is not reduced.

Thermally broken

No cold air transfer from outside to inside.

i-Flux®

Thanks to its self-regulating flap, the Invisivent^{EVO} HR ensures the supply of fresh and healthy air without draughts. Moreover, the interior profile deflects the incoming air upwards, causing an optimal spread of fresh air in the room.

Sound absorbing

In open position:

Invisivent^{EVO} HR Basic: 34 (0;-1) dB

Invisivent^{EVO} HR High: 39 (0;-1) dB

Invisivent^{EVO} HR Ultra: 42 (0;-2) dB

Removable acoustic foam

Insect mesh

Burglar proof

The Invisivent^{EVO} range meets the requirements of burglary resistance class 2 according to standard prEN 1627 to 1630, and therefore suits to be used on a window class WK2.



Invisivent® EVO HR Basic < Acoustic overframe flap ventilators

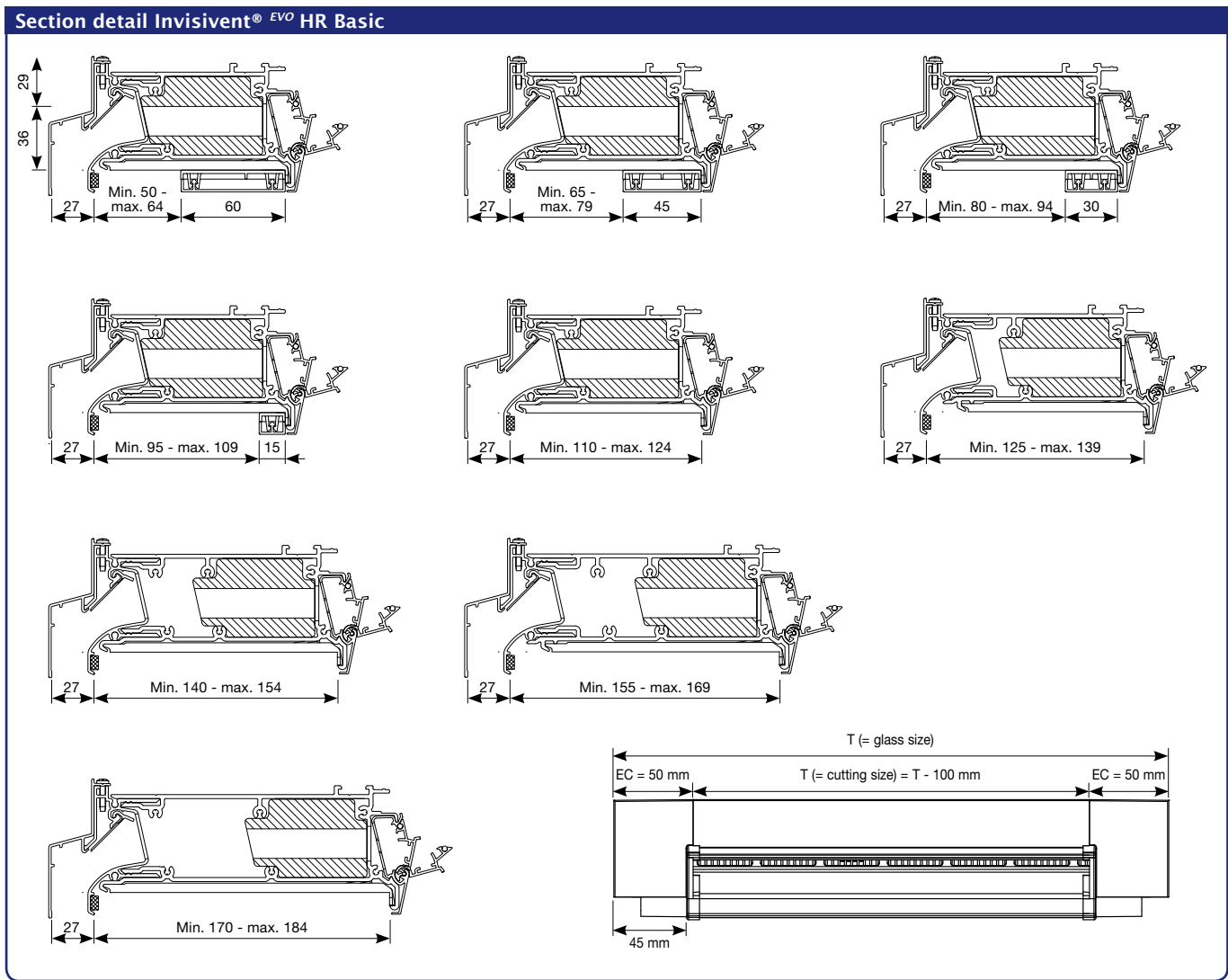

Technical characteristics	Invisivent® EVO HR Basic
Airflow	
Equivalent area	13489 mm ² /m
Q at 1 Pa	10,6 l/s/m
Q at 1 Pa	38,2 m ³ /h/m
Q at 2 Pa	15,9 l/s/m
Q at 10 Pa	17,9 l/s/m
Q at 20 Pa	16,0 l/s/m
Comfort	
Sound reduction D _{n,e,w} (C;C _{tr})	
- in open position	34 (0;-1) dB
- in closed position	57 (-1;-4) dB
Technical characteristics	
Controllable internal flap	16 stepped positions
Control options internal flap	Manual, cord, rod, motor
U value	2,0 W/m ² K
Air leakage at 50 Pa	<15% (in closed position)
Watertightness in closed position, up to	1200 Pa
Watertightness in open position, up to	250 Pa
Dimensions	
Glass reduction	0 mm
Height	65 mm
Depths window frame	50 up to 184 mm (or more upon request)
Max. length	6000 mm

Section detail Invisivent® EVO HR High

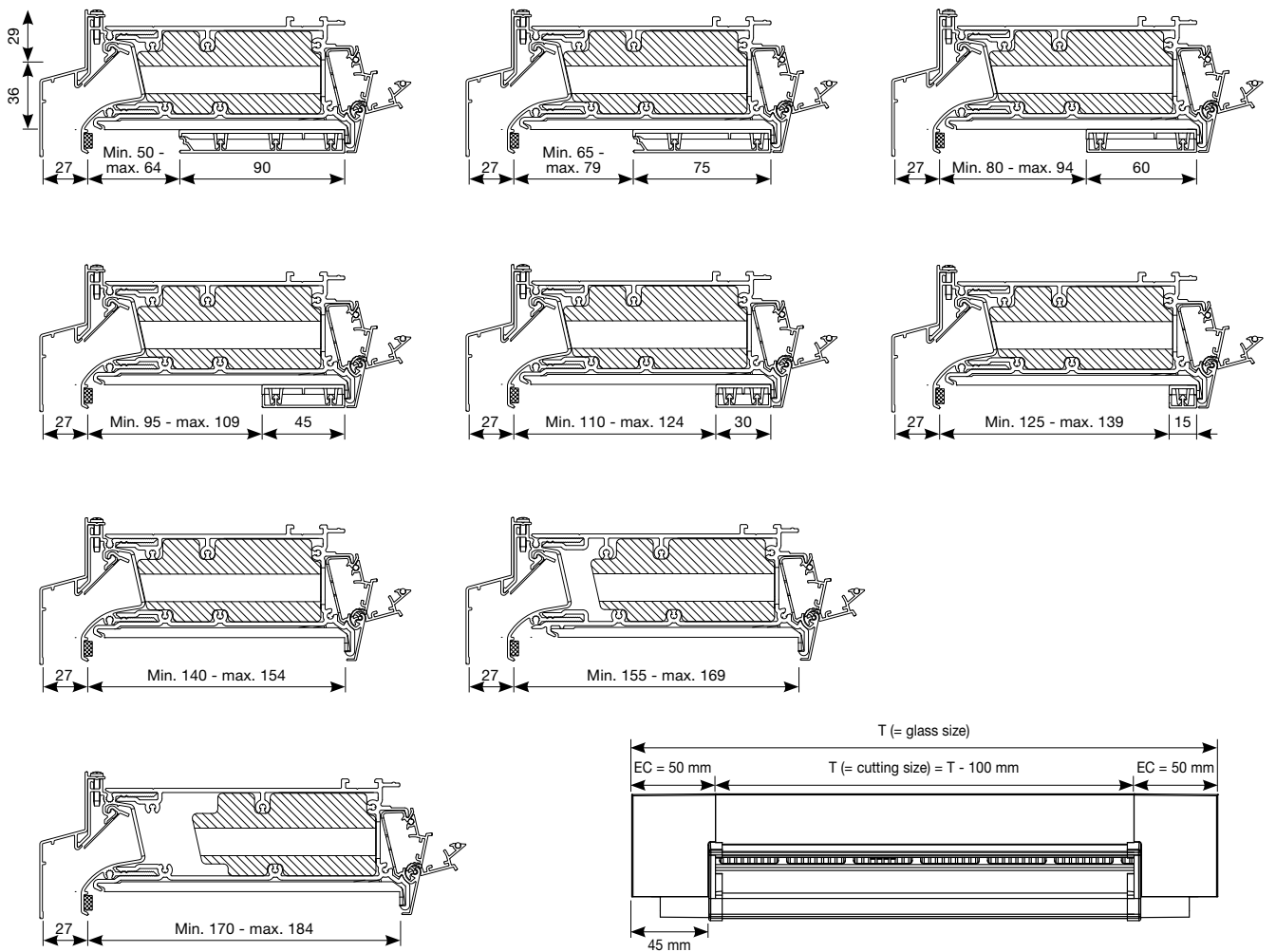

Technical characteristics	Invisivent® EVO HR High
Airflow	
Equivalent area	9349 mm ² /m
Q at 1 Pa	7,3 l/s/m
Q at 1 Pa	26,5 m ³ /h/m
Q at 2 Pa	11,6 l/s/m
Q at 10 Pa	14,0 l/s/m
Q at 20 Pa	11,8 l/s/m
Comfort	
Sound reduction D _{n,e,w} (C;C _{tr})	
- in open position	39 (0;-1) dB
- in closed position	62 (-2;-6) dB
Technical characteristics	
Controllable internal flap	16 stepped positions
Control options internal flap	Manual, cord, rod, motor
U value	2,2 W/m ² K
Air leakage at 50 Pa	<15% (in closed position)
Watertightness in closed position, up to	1200 Pa
Watertightness in open position, up to	250 Pa
Dimensions	
Glass reduction	0 mm
Height	65 mm
Depths window frame	50 up to 184 mm (or more upon request)
Max. length	6000 mm



Invisivent® EVO HR Ultra < Acoustic overframe flap ventilators

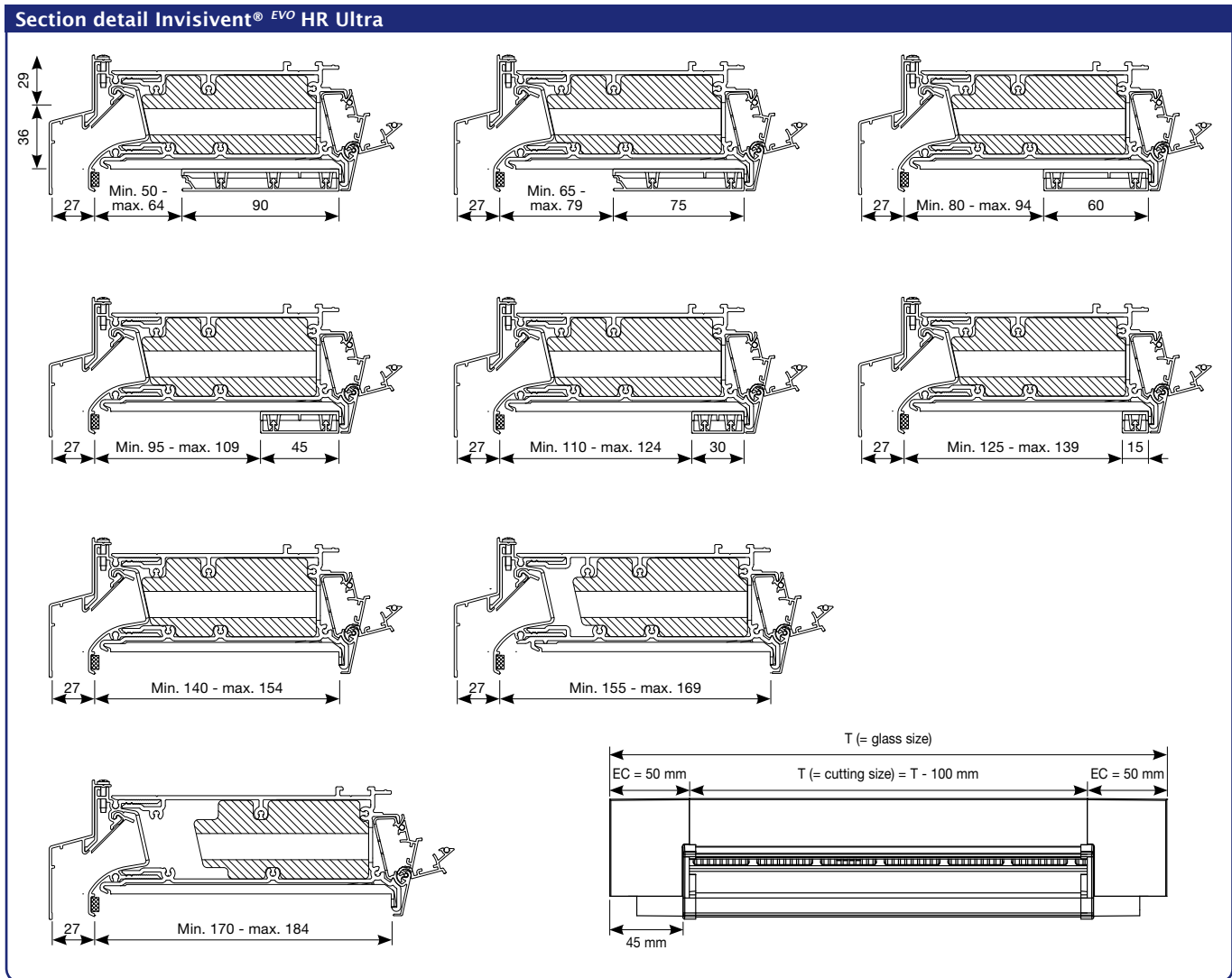

Technical characteristics	Invisivent® EVO HR Ultra
Airflow	
Equivalent area	7016 mm ² /m
Q at 1 Pa	5,5 l/s/m
Q at 1 Pa	19,9 m ³ /h/m
Q at 2 Pa	9,1 l/s/m
Q at 10 Pa	8,0 l/s/m
Q at 20 Pa	9,8 l/s/m
Comfort	
Sound reduction $D_{n,e,w}$ ($C; C_{tr}$)	
- in open position	42 (0;-2) dB
- in closed position	64 (-1;-4) dB
Technical characteristics	
Controllable internal flap	16 stepped positions
Control options internal flap	Manual, cord, rod, motor
U value	2,2 W/m ² K
Air leakage at 50 Pa	<15% (in closed position)
Watertightness in closed position, up to	1200 Pa
Watertightness in open position, up to	250 Pa
Dimensions	
Glass reduction	0 mm
Height	65 mm
Depths window frame	50 up to 184 mm (or more upon request)
Max. length	6000 mm

Acoustic retrofit module for the Invisivent®^{EVO}

Over the years, one's neighbourhood can change dramatically, with for example increasing traffic leading to increasing noise pollution. With the AKR33-module it is possible to upgrade one's previously installed Invisivent^{EVO} with a minimal sound absorbing module, so that one can enjoy his home again in all comfort.

Acoustic retrofit module

RENSON has developed a special acoustic retrofit module that can easily be clicked on a previously installed Invisivent^{EVO}.

Thermally broken

No cold air transfer from outside to inside.

i-Flux®

Thanks to its self-regulating flap, the Invisivent^{EVO} AKR33-module ensures the supply of fresh and healthy air without draughts. Moreover, the interior profile deflects the incoming air upwards, causing an optimal spread of fresh air in the room.

Sound absorbing

Invisivent^{EVO} + AKR33-module: 33 (-1;-2) dB in open position

Available in the same color as the Invisivent®^{EVO}

Insect mesh

Burglar proof

The Invisivent^{EVO} range meets the requirements of burglary resistance class 2 according to standard prEN 1627 to 1630, and therefore suits to be used on a window class WK2.

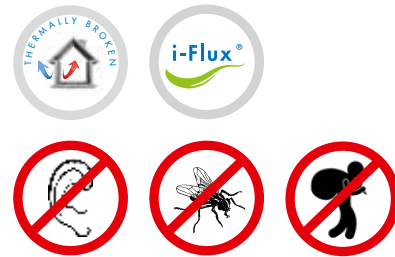

Technical characteristics	AKR33-module
Airflow	
Equivalent area	11818 mm ² /m
Q at 1 Pa	9,3 l/s/m
Q at 1 Pa	33,4 m ³ /h/m
Q at 2 Pa	12,9 l/s/m
Q at 10 Pa	11,6 l/s/m
Q at 20 Pa	12,9 l/s/m
Comfort	
Sound reduction D _{n,e,w} (C;C _{tr})	
- in open position	33 (-1;-2) dB
- in closed position	46 (0;-2) dB
Technical characteristics	
Controllable internal flap	6 stepped positions
Control options internal flap	Manual, cord, rod, motor
U value	3,6 W/m ² K
Air leakage at 50 Pa	<15% (in closed position)
Watertightness in closed position, up to	650 Pa
Watertightness in open position, up to	50 Pa

Installation

1. Remove the aluminium interior profile from the Invisivent^{EVO}
2. Click the acoustic AKR33-module onto the PVC-profile of the Invisivent^{EVO}
3. Insert the aluminium interior profile from the Invisivent^{EVO} on the acoustic AKR33-module

Invisivent® EVO UT < Acoustic overframe flap ventilators

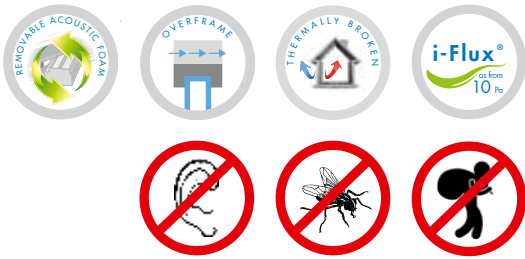

The most discrete, self-regulating and sound-absorbing overframe flap ventilator for utility buildings

The Invisivent^{EVO} UT is the acoustic version of the Invisivent^{EVO} that has been especially developed for utility buildings. Its self-regulating flap only starts working at a wind pressure of 10 Pa (instead of at 2 Pa as for the other Invisivent^{EVO} vents), ensuring a constant higher level of basic ventilation. **This type of window ventilation is only suitable for utility applications in which both the natural supply and mechanical extraction are located in the same room.**

Window depth < 140 mm: Invisivent^{EVO} UT + special extension profile (>140 mm, an adapted PVC interior profile is used)

Utility buildings

Installation on top of the window frame

The Invisivent^{EVO} UT is a thermally broken window ventilator that is installed on top of the aluminium, timber or PVC window frame. This almost invisible installation guarantees maximum light penetration as the glass size is not reduced.

Thermally broken

No cold air transfer from outside to inside.

i-Flux®

Thanks to its self-regulating flap, the Invisivent^{EVO} UT ensures the supply of fresh and healthy air without draughts. The self-regulating flap only starts working at a wind pressure of 10 Pa (instead of at 2 Pa). Moreover, the interior profile deflects the incoming air upwards, causing an optimal spread of fresh air in the room.

Sound absorbing

Invisivent^{EVO} UT: 39 (0;-1) dB in open position

Removable acoustic foam

Insect mesh

Burglar proof

The Invisivent^{EVO} range meets the requirements of burglary resistance class 2 according to standard prEN 1627 to 1630, and therefore suits to be used on a window class WK2.



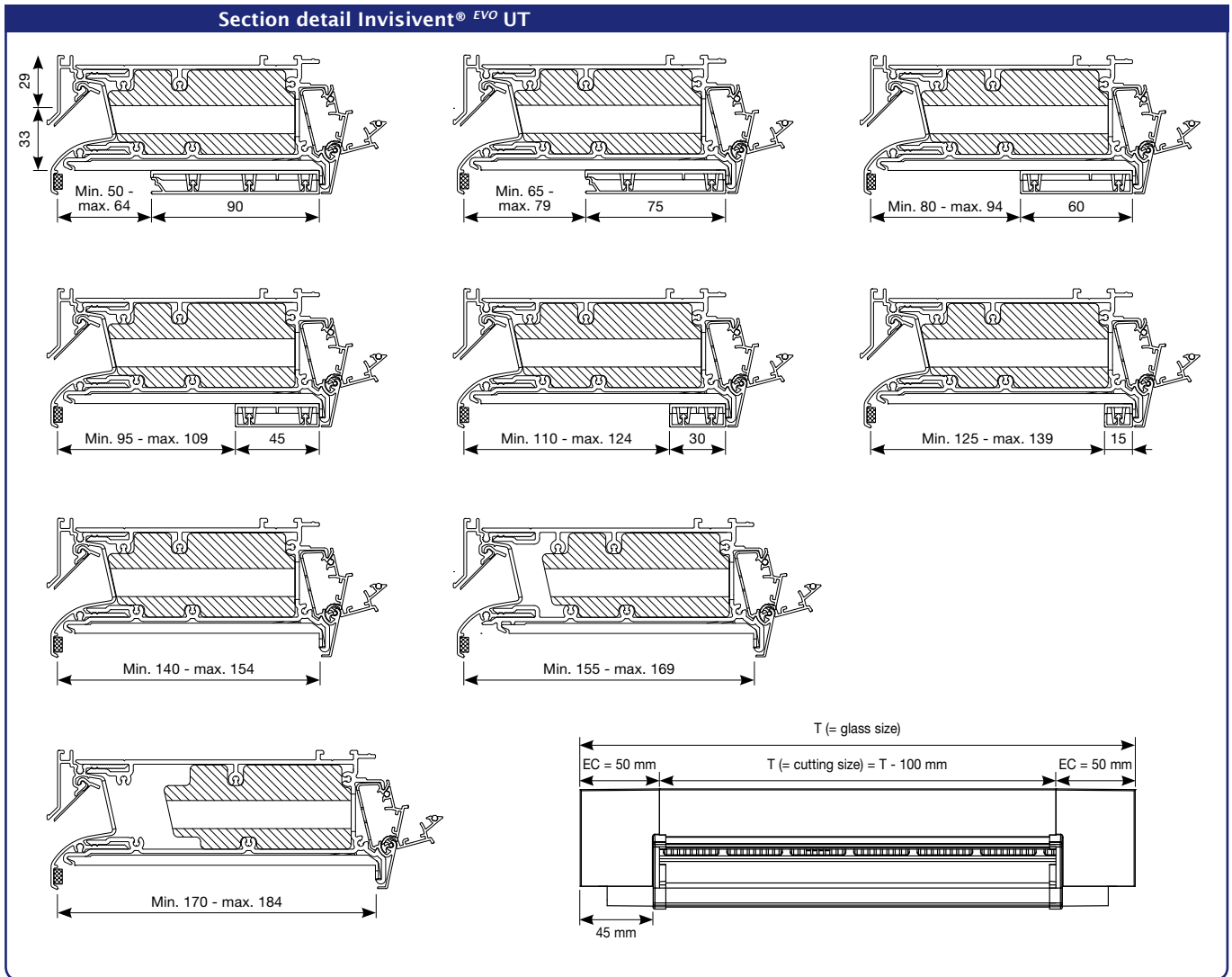

Technical characteristics	Invisivent® EVO UT
Airflow	
Equivalent area	10092 mm ² /m
Q at 1 Pa	7,9 l/s/m
Q at 1 Pa	28,6 m ³ /h/m
Q at 2 Pa	12,3 l/s/m
Q at 10 Pa	30,7 l/s/m
Q at 20 Pa	33,6 l/s/m
Comfort	
Sound reduction D _{n,e,w} (C;C _{tr})	
- in open position	39 (0;-1) dB
- in closed position	62 (-2;-6) dB
Technical characteristics	
Controllable internal flap	5 stepped position
Control options internal flap	Manual, cord, rod, motor
U value	2,2 W/m ² K
Air leakage at 50 Pa	<15% (in closed position)
Watertightness in closed position, up to	900 Pa
Watertightness in open position, up to	150 Pa
Dimensions	
Glass reduction	0 mm
Height	62 mm
Depths window frame	50 up to 184 mm (or more upon request)
Max. length	6000 mm



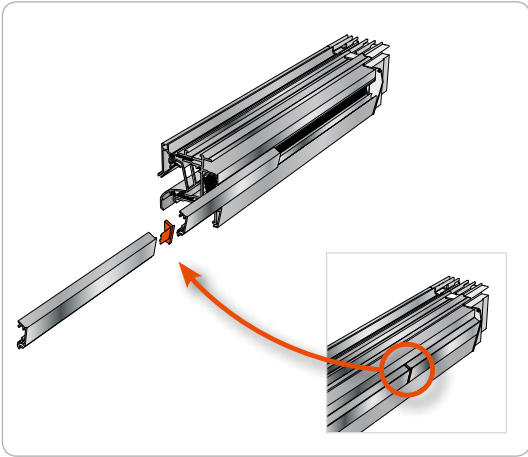

Control flap

For ease of use or at the customer's request, the control flap is split up for lengths above 3500 mm. A special middle piece (3 mm thick) is inserted between the two flaps to give a neat finish.

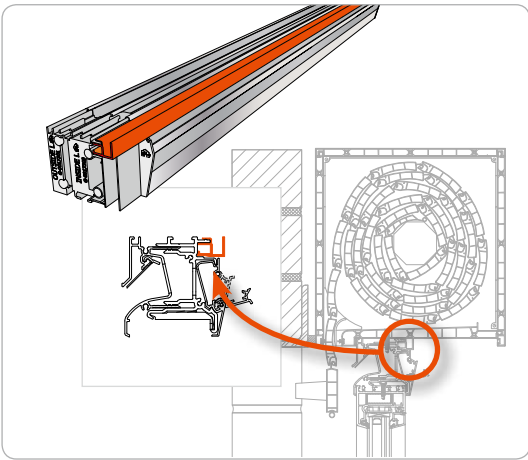

Finishing profile

The Invisivent^{EVO} is designed to provide a perfect finish. There is a cut-out at the top of the vent that takes plasterboard or MDF panels up to 10 mm thick, and which allows the plasterer to integrate the vent discreetly into the plastered surface. The optional aluminium finishing profile should be used with traditional wet plastering. The profile should also be used for a perfect finish when installing a roller shutter box, for example, above the Invisivent^{EVO}. This profile is available in the same finish as the inside of the Invisivent^{EVO}.

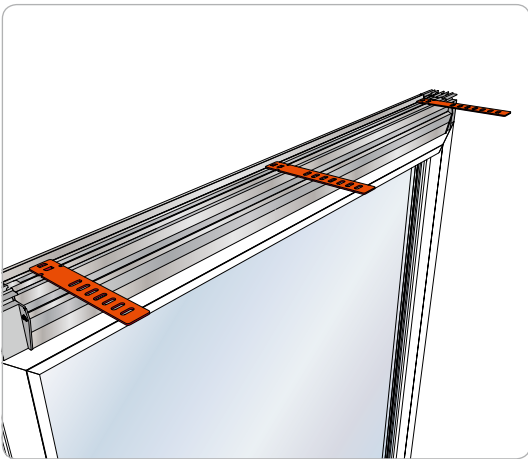
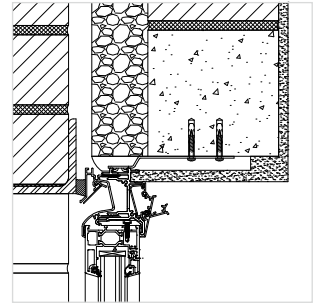

Installation using wall brackets

The Invisivent^{EVO} has a dowel slot so it can be attached quickly and easily to the unfinished structure by using wall brackets.

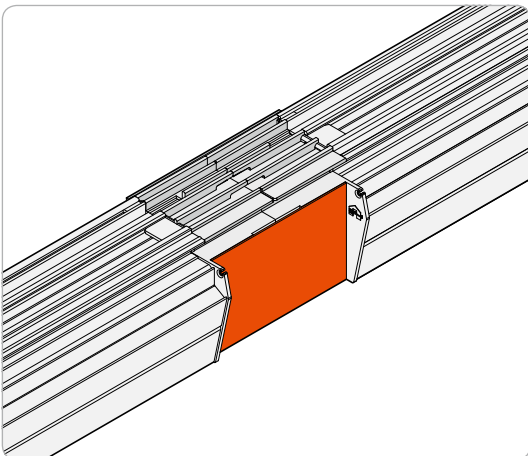

Split up middle piece

An Invisivent^{EVO} is available in lengths up to 6 meter. However, it is also possible to install several Invisivent^{EVO} vents next to each other, joined by a split up middle piece for a perfect finish.

Rain cap

In case of exposure to extreme weather conditions (rain, sand, high wind loads,...), a rain cap can be added to the Invisivent^{EVO}, ensuring high comfort at all times.

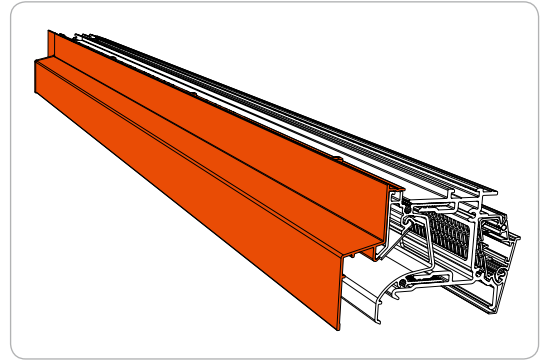
**Side mounting plate**

The use of side mounting plates is recommended to ensure that the Invisivent^{EVO} fits securely to the window.

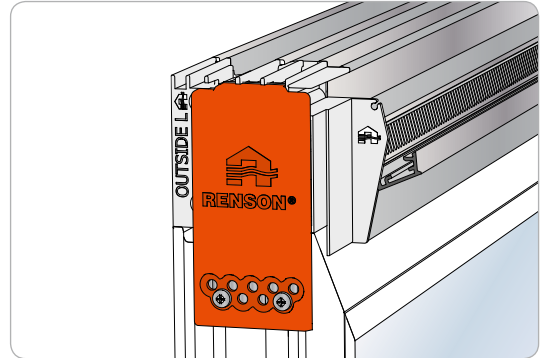
**Airflow limiters**

Airflow limiters can easily be clipped into the Invisivent^{EVO}. They close the opening by 100 mm so that the maximum flow can be adjusted to suit your needs.

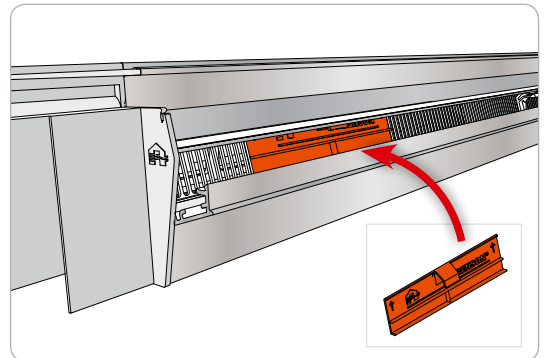
**Removable acoustic foam**

The acoustic foam can be removed (and cleaned or substituted) from the Invisivent^{EVO} through the perforated PVC profile.

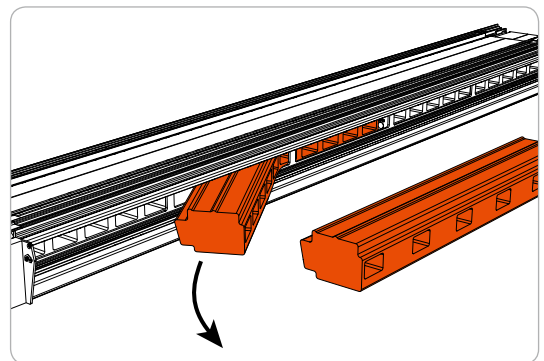
**“Permanently open” clip**

If required, the Invisivent^{EVO} can be supplied with a special clip to keep the unit permanently open (e.g. for open gas appliances). This clip can also be retrofitted.



TC45 < Flap ventilators glazed-in/at transom



Compact flap vent with a good price/quality ratio

The compact TC45 is a non-selfregulating, thermally broken aluminium glazed-in window vent with a soft-line design outer profile. The internal flap directs the incoming airflow upwards and can be placed in 5 positions.

Glazed-in installation (or at transom)

The TC45 can be installed glazed-in, or at transom using the additional transom profiles.

Thermally broken

No cold air transfer from outside to inside.

Coanda effect

The interior profile deflects the incoming air upwards, causing an optimal spread of fresh air in the room.

Insect mesh



Section detail

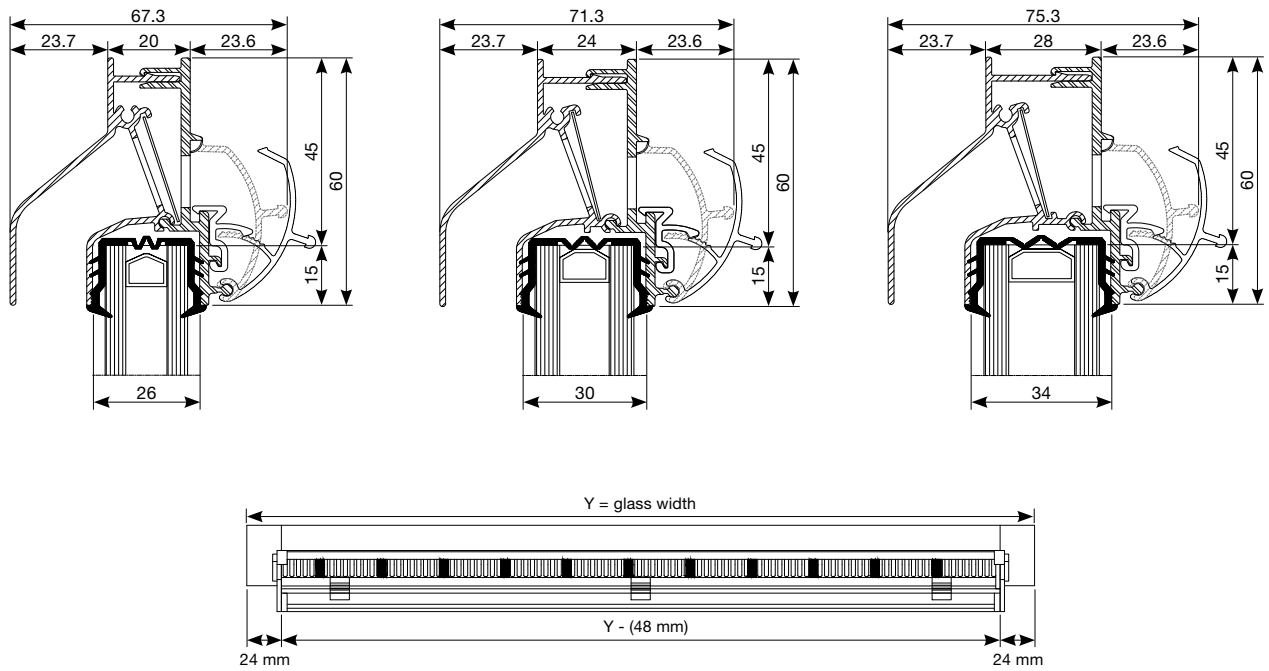

Technical characteristics	TC45
Airflow	
Equivalent area	10435 mm ² /m
Q at 1 Pa	8,2 l/s/m
Q at 1 Pa	29,5 m ³ /h/m
Q at 2 Pa	11,5 l/s/m
Q at 10 Pa	25,8 l/s/m
Q at 20 Pa	36,5 l/s/m
Comfort	
Sound reduction $D_{n,e,w}$ (C;C _{tr})	
- in open position	27 (0;0) dB
- in closed position	37 (-1;-2) dB
Technical characteristics	
Controllable internal flap	5 stepped positions
Control options internal flap	Manual, cord, rod
U value	4,1 W/m ² K
Air leakage at 50 Pa	<15% (in closed position)
Watertightness in closed position, up to	650 Pa
Watertightness in open position, up to	n.p.d.
Dimensions	
Glass reduction	45 mm
Height	60 mm
Glass thickness	20, 24 or 28 mm
Max. length	2500 mm



TC60 < Flap ventilators glazed-in/at transom

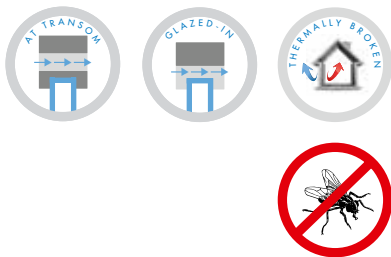

Compact flap vent with an excellent price/quality ratio

The TC60 is a non-selfregulating, thermally broken aluminium glazed-in window vent with a soft-line design outer profile, having an excellent price/quality ratio. The internal flap directs the incoming airflow upwards and can be continuously controlled.

Glazed-in installation (or at transom)

The TC60 has been developed for glazed-in installation, and can be integrated in aluminium, timber and PVC window profiles with a depth of 20, 24 or 28 mm. The TC60 can optionally also be installed at transom, using the additional transom profiles.

Thermally broken

No cold air transfer from outside to inside.

Excellent price/quality ratio

Insect mesh



Section detail

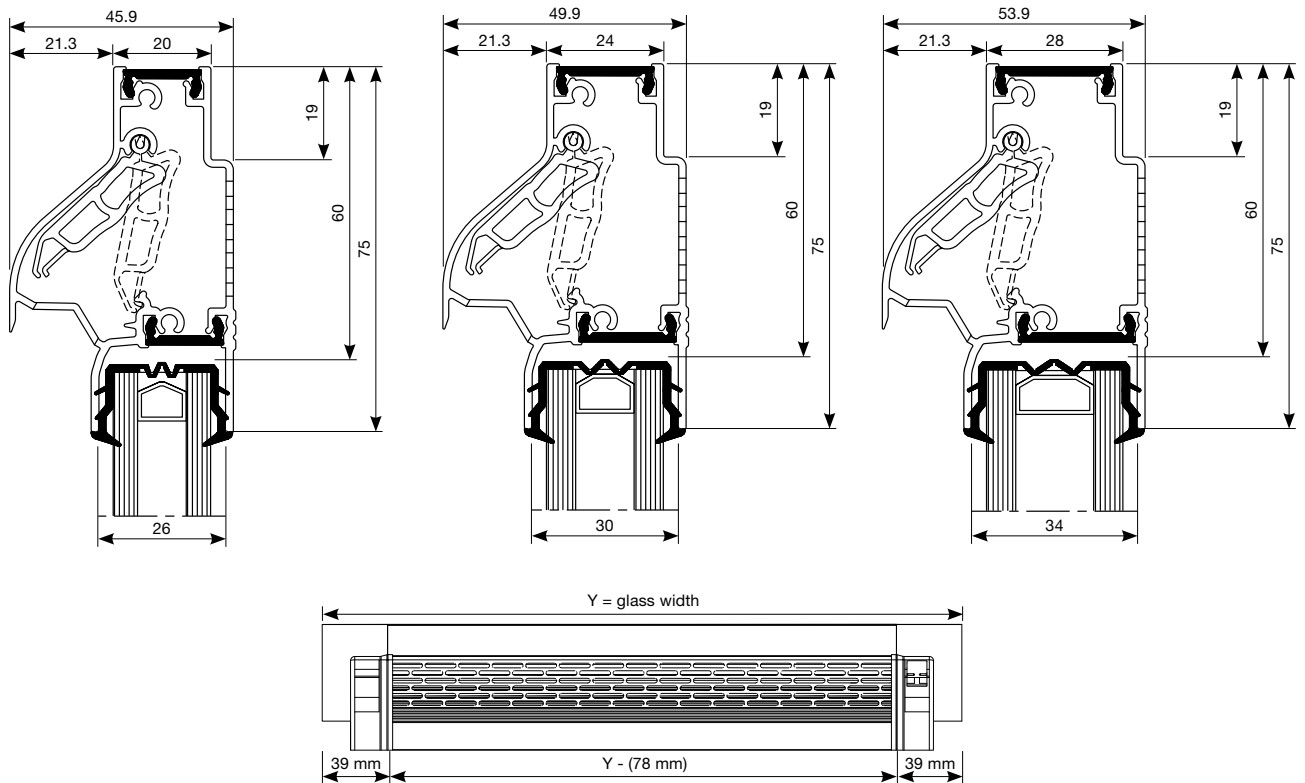

Technical characteristics	TC60
Airflow	
Equivalent area	15652 mm ² /m
Q at 1 Pa	12,3 l/s/m
Q at 1 Pa	44,3 m ³ /h/m
Q at 2 Pa	17,4 l/s/m
Q at 10 Pa	38,9 l/s/m
Q at 20 Pa	55,0 l/s/m
Comfort	
Sound reduction $D_{n,e,w}$ (C;C _{tr})	
- in open position	28 (0;0) dB
- in closed position	42 (0;0) dB
Technical characteristics	
Controllable internal flap	continuous adjustment
Control options internal flap	Manual, cord, rod
U value	3,3 W/m ² K
Air leakage at 50 Pa	<15% (in closed position)
Watertightness in closed position, up to	650 Pa
Watertightness in open position, up to	10 Pa
Dimensions	
Glass reduction	60 mm
Height	75 mm
Glass thickness	20, 24 or 28 mm
Max. length	2500 mm



AR60-THK60 < Flap ventilators glazed-in/at transom



AR60: Self-regulating flap vent with external hood for improved weather protection

The interior profile of the AR60 deflects the incoming air upwards so that fresh air is optimally spread in the room. It also has an external hood for additional weather protection.

The AR60 is also available with permanently open clips (e.g. for open gas appliances).

Glazed-in installation (or at transom)

The AR60 has been developed for glazed-in installation, and can be integrated in aluminium, timber and PVC window profiles with a depth of 20, 24 or 28 mm. The AR60 can optionally also be installed at transom, using the additional transom profiles.

Thermally broken

No cold air transfer from outside to inside.

i-Flux®

Thanks to its self-regulating flap, the AR60 ensures the supply of fresh and healthy air without draughts. Moreover, the interior profile deflects the incoming air upwards, causing an optimal spread of fresh air in the room.

Insect mesh

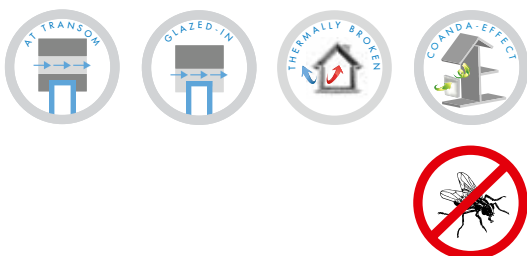

THK60: Flap vent with external hood for improved weather protection

The THK60 is a thermally broken, slimline glazed-in ventilator for application in aluminium, timber and PVC windows. The internal tip directs the flow of incoming air upwards, and can be placed in 5 positions. The THK60 is also available with permanently open clips (e.g. for open gas appliances).

Glazed-in installation (or at transom)

The THK60 has been developed for glazed-in installation, and can be integrated in aluminium, timber and PVC window profiles with a depth of 20, 24 or 28 mm. The THK60 can optionally also be installed at transom, using the additional transom profiles.

Thermally broken

No cold air transfer from outside to inside.

Coanda-effect

The interior profile deflects the incoming air upwards, causing an optimal spread of fresh air in the room.

Insect mesh



Section detail

AR60

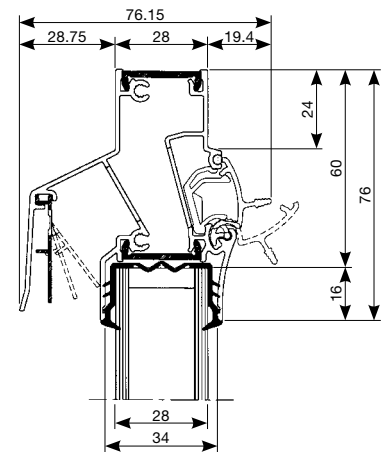
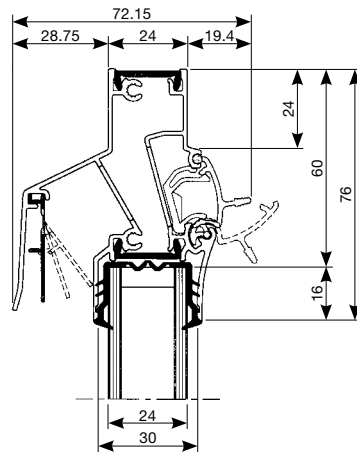
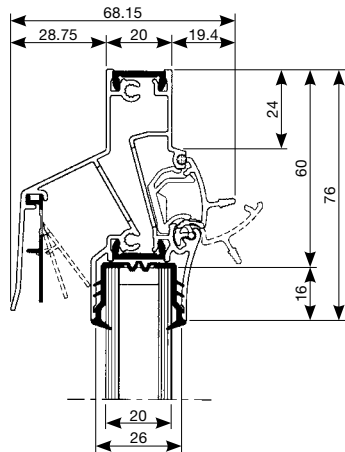

Endcap size = 33 mm

THK60

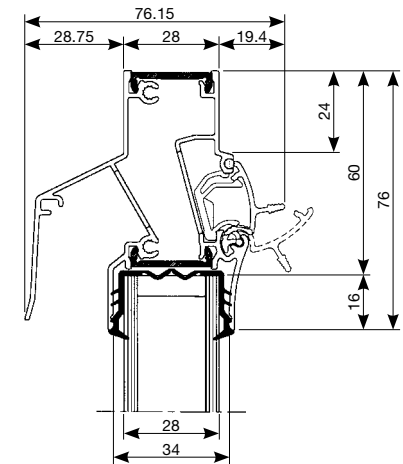
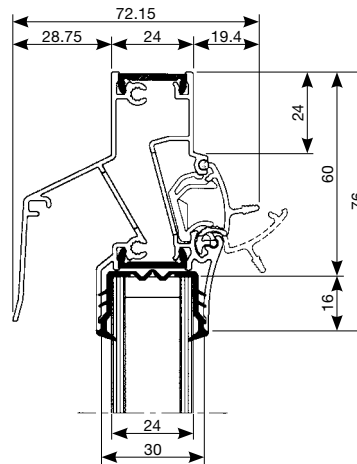
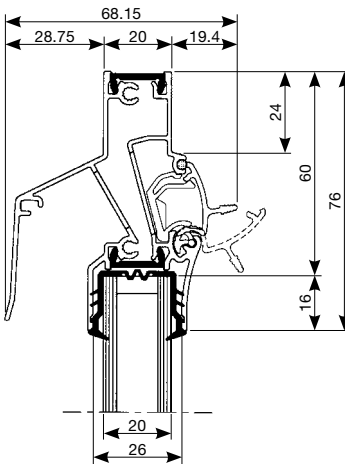

Endcap size = 33 mm

Technical characteristics	AR60	THK60
Airflow		
Equivalent area	10427 mm ² /m	11841 mm ² /m
Q at 1 Pa	8,2 l/s/m	9,3 l/s/m
Q at 1 Pa	29,5 m ³ /h/m	33,5 m ³ /h/m
Q at 2 Pa	11,8 l/s/m	13,2 l/s/m
Q at 10 Pa	19,7 l/s/m	29,6 l/s/m
Q at 20 Pa	23,9 l/s/m	41,8 l/s/m
Comfort		
Sound reduction D _{n,e,w} (C;C _{tr})		
- in open position	27 (0;0) dB	27 (0;0) dB
- in closed position	44 (0;0) dB	44 (0;0) dB
Technical characteristics		
Controllable internal flap	5 stepped positions	5 stepped positions
Control options internal flap	Manual, cord, rod	Manual, cord, rod
U value	4,5 W/m ² K	4,5 W/m ² K
Air leakage at 50 Pa	<15% (in closed position)	<15% (in closed position)
Watertightness in closed position, up to	650 Pa	650 Pa
Watertightness in open position, up to	100 Pa	50 Pa
Dimensions		
Glass reduction	60 mm	60 mm
Height	76 mm	76 mm
Glass thickness	20, 24 or 28 mm	20, 24 or 28 mm
Max. length	2500 mm	2500 mm

AR75 < Flap ventilators glazed-in/at transom



Excellent self-regulating window vent with 4 different airflows in 1 design

Due to its unique patented inner mechanism, 4 different airflow levels can be reached while the AR75 visually maintains the same look.

Glazed-in installation (or at transom)

The AR75 has been developed for glazed-in installation, and can be integrated in aluminium, timber and PVC window profiles. This vent can also be installed at transom using an additional transom profile.

Thermally broken

No cold air transfer from outside to inside.

Self-regulating

Thanks to its self-regulating flap, the AR75 ensures the supply of fresh and healthy air without draughts.

4 different airflow levels with 1 single design

Due to its internal mechanism, the AR75 can obtain 4 different airflow levels. This allows to use the same vent (visually) in order to provide different rooms, each with their specific ventilation needs, with fresh air.

Insect mesh



Section detail

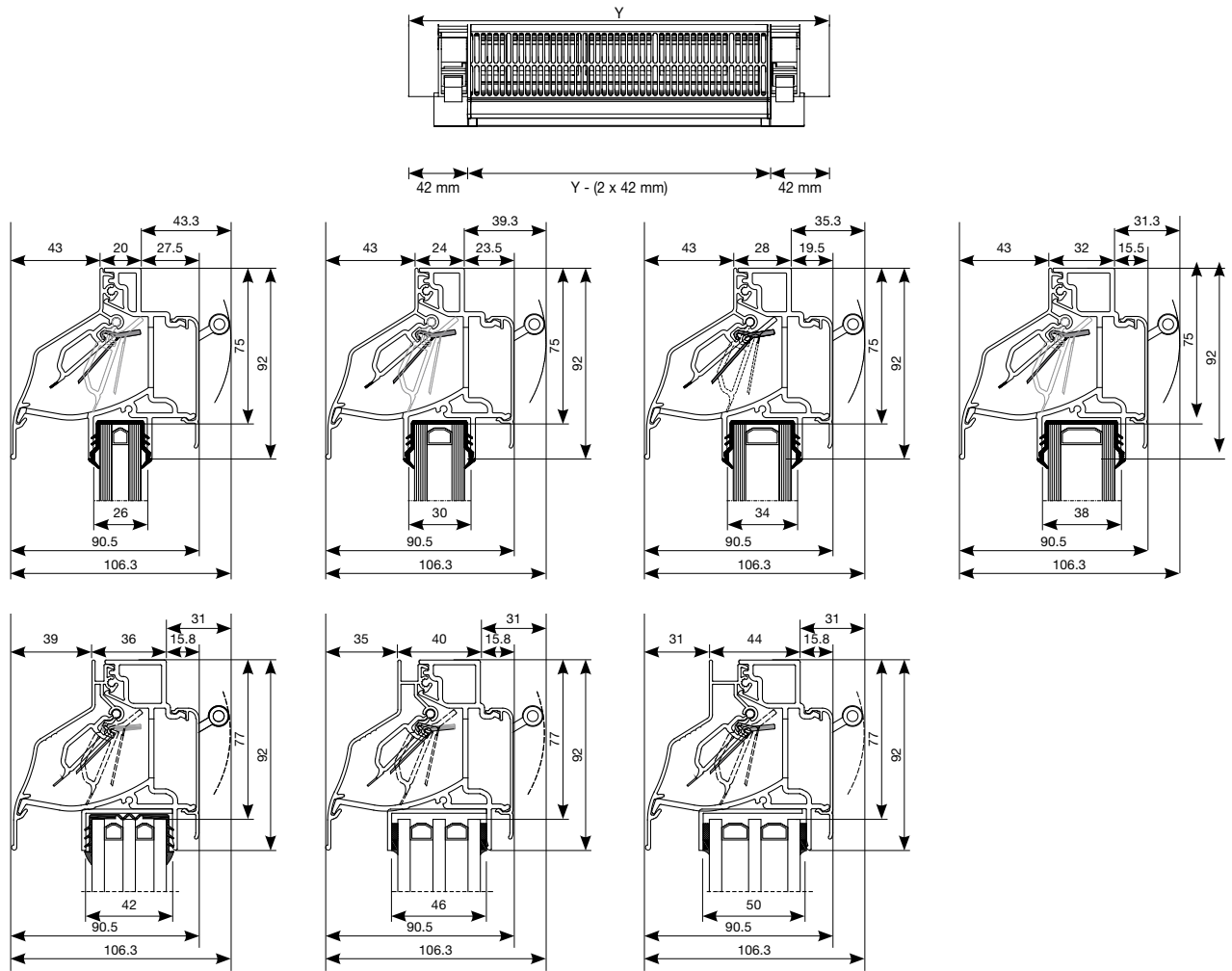

Technical characteristics	Small	Medium	Large	Xlarge
Airflow				
Equivalent area	14174 mm ² /m	17409 mm ² /m	19034 mm ² /m	24301 mm ² /m
Q at 1 Pa	11,1 l/s/m	13,7 l/s/m	15,0 l/s/m	19,1 l/s/m
Q at 1 Pa	40,1 m ³ /h/m	49,3 m ³ /h/m	53,9 m ³ /h/m	68,8 m ³ /h/m
Q at 2 Pa	15,3 l/s/m	18,8 l/s/m	22,6 l/s/m	29,0 l/s/m
Q at 10 Pa	17,3 l/s/m	21,4 l/s/m	24,5 l/s/m	31,5 l/s/m
Q at 20 Pa	14,7 l/s/m	18,9 l/s/m	21,7 l/s/m	28,0 l/s/m
Comfort				
Sound reduction $D_{n,e,w}$ (C;C _{tr})				
- in open position	26 (-1;-1) dB	26 (-1;-2) dB	26 (-1;-2) dB	26 (-1;-1) dB
- in closed position	43 (-1;-1) dB	43 (-1;-1) dB	43 (-1;-1) dB	43 (-1;-1) dB
Technical characteristics				
Controllable internal flap	Continuous adjustment			
Control options internal flap	Manual, cord, rod, motor			
U value	3,0 W/m ² K			
Air leakage at 50 Pa	<15% (in closed position)			
Watertightness in closed position, up to	650 Pa			
Watertightness in open position, up to	50 Pa			
Dimensions				
Glass reduction	75 mm (glass thickness: 20, 24, 28, and 32 mm) / 77 mm (glass thickness: 36, 40 and 44 mm)			
Height	92 mm			
Glass thickness	20, 24, 28, 32, 36*, 40*, 44* mm			20, 24, 28, 32, 36* mm
Max. length	2500 mm			

* not for installation at transom

AR90-THK90 < Flap ventilators glazed-in/at transom



Self-regulating flap vent with external hood for improved weather protection

The AR90 is the self-regulating version of the THK90. A self-regulating flap is integrated, reacting automatically to various wind pressures and thus preventing draughts. As the THK90, the AR90 has an external hood for additional weather protection.

Glazed-in installation (or at transom)

The AR90 has been developed for glazed-in installation, and can be integrated in aluminium, timber and PVC window profiles with a depth of 20, 24 or 28 mm. The AR90 can optionally also be installed at transom, using the additional transom profiles.

Thermally broken

No cold air transfer from outside to inside.

Self-regulating

Thanks to its self-regulating flap, the AR90 ensures the supply of fresh and healthy air without draughts.

Flat interior profile

Thanks to its flat interior profile, the AR90 is the ideal solution for integration in the fixed part of sash windows.

Insect mesh

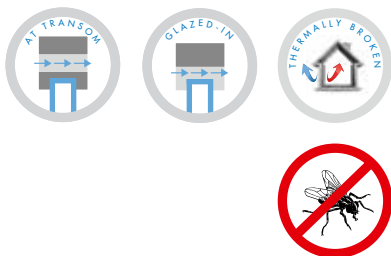

Flap vent with external hood for improved weather protection

The non self-regulating THK90 has a flat interior profile, which makes it a good solution for the integration in the fixed part of sash windows. The THK90 also has an external hood for additional weather protection.

Glazed-in installation (or at transom)

The THK90 has been developed for glazed-in installation, and can be integrated in aluminium, timber and PVC window profiles with a depth of 20, 24 or 28 mm. The THK90 can optionally also be installed at transom, using the additional transom profiles.

Thermally broken

No cold air transfer from outside to inside.

Flat interior profile

Thanks to its flat interior profile, the THK90 is a good solution for integration in the fixed part of sash windows.

Insect mesh



Section detail

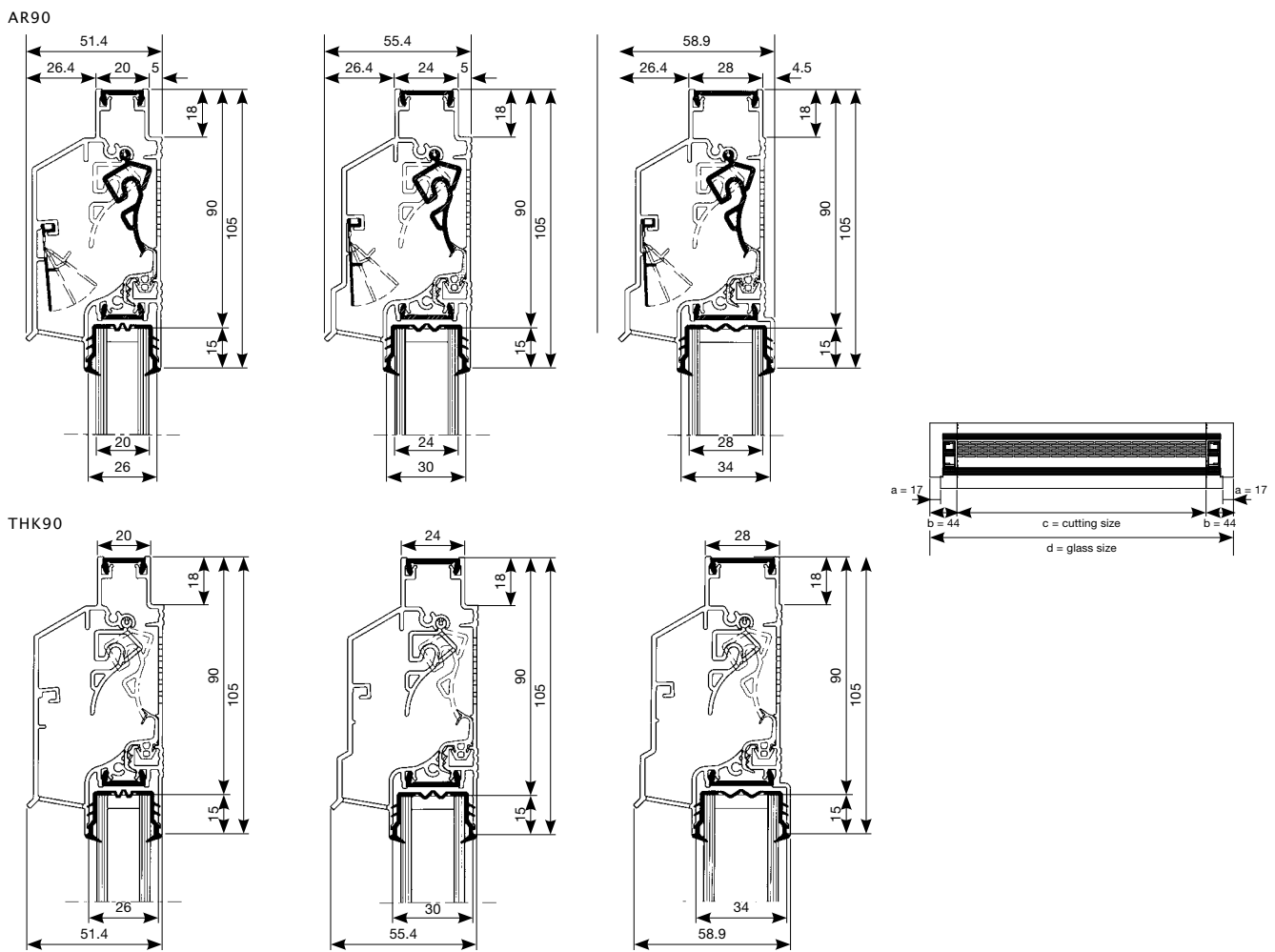

Technical characteristics	AR90	THK90
Airflow		
Equivalent area	14252 mm ² /m	14736 mm ² /m
Q at 1 Pa	11,2 l/s/m	11,6 l/s/m
Q at 1 Pa	40,3 m ³ /h/m	41,7 m ³ /h/m
Q at 2 Pa	15,6 l/s/m	16,1 l/s/m
Q at 10 Pa	11,4 l/s/m	34,5 l/s/m
Q at 20 Pa	9,1 l/s/m	48,0 l/s/m
Comfort		
Sound reduction D _{n,e,w} (C;C _{tr})		
- in open position	30 (-1;-2) dB	28 (0;-1) dB
- in closed position	45 (-1;-3) dB	44 (0;-1) dB
Technical characteristics		
Controllable internal flap	5 posities	5 posities
Control options internal flap	Manual, cord, rod, motor	Manual, cord, rod, motor
U value	3,9 W/m ² K	3,9 W/m ² K
Air leakage at 50 Pa	<15% (in closed position)	<15% (in closed position)
Watertightness in closed position, up to	650 Pa	650 Pa
Watertightness in open position, up to	100 Pa	50 Pa
Dimensions		
Glass reduction	90 mm	90 mm
Height	105 mm	105 mm
Glass thickness	20, 24 or 28 mm	20, 24 or 28 mm
Max. length	2500 mm (2000 mm for motorised control)	2500 mm (2000 mm for motorised control)

THM90^{EVO}/THM90PB^{EVO}/THM90TR^{EVO} < Flap ventilators glazed-in/at transom



Self-regulating flush window vent, ideal for sliding doors

The THM90^{EVO} is an entirely flat window vent, which makes this the ideal product for integration in sliding doors. Three different types of THM90^{EVO} are available, each for different glass thicknesses: THM90^{EVO} for glazed-in installation, THM90PB^{EVO} for installation at the bottom of the window, and the THM90TR^{EVO} for installation between profiles (at transom).

By combining a THM90PB^{EVO} in the lower part and a THM90^{EVO} in the upper part of a conservatory, the THM90^{EVO} is ideal for natural ventilation by convection.

Glazed-in installation (or at transom)

The THM90^{EVO} has been developed for glazed-in installation, and can be integrated in aluminium, timber and PVC window profiles. The THM90^{EVO} can be installed on glass, at the bottom of the window (THM90PB^{EVO}), and at transom (THM90TR^{EVO}). The THM90^{EVO} should only be used for installation on ground floors.

Thermally broken

No cold air transfer from outside to inside.

Self-regulating

Thanks to its self-regulating flap, the THM90^{EVO} ensures the supply of fresh and healthy air without draughts.

Entirely flat profiles

Thanks to its flat profiles, the THM90^{EVO} is the perfect solution for integration in sash windows.

Insect mesh



Flap ventilators glazed-in/at transom > THM90^{EVO}/THM90PB^{EVO}/THM90TR^{EVO}

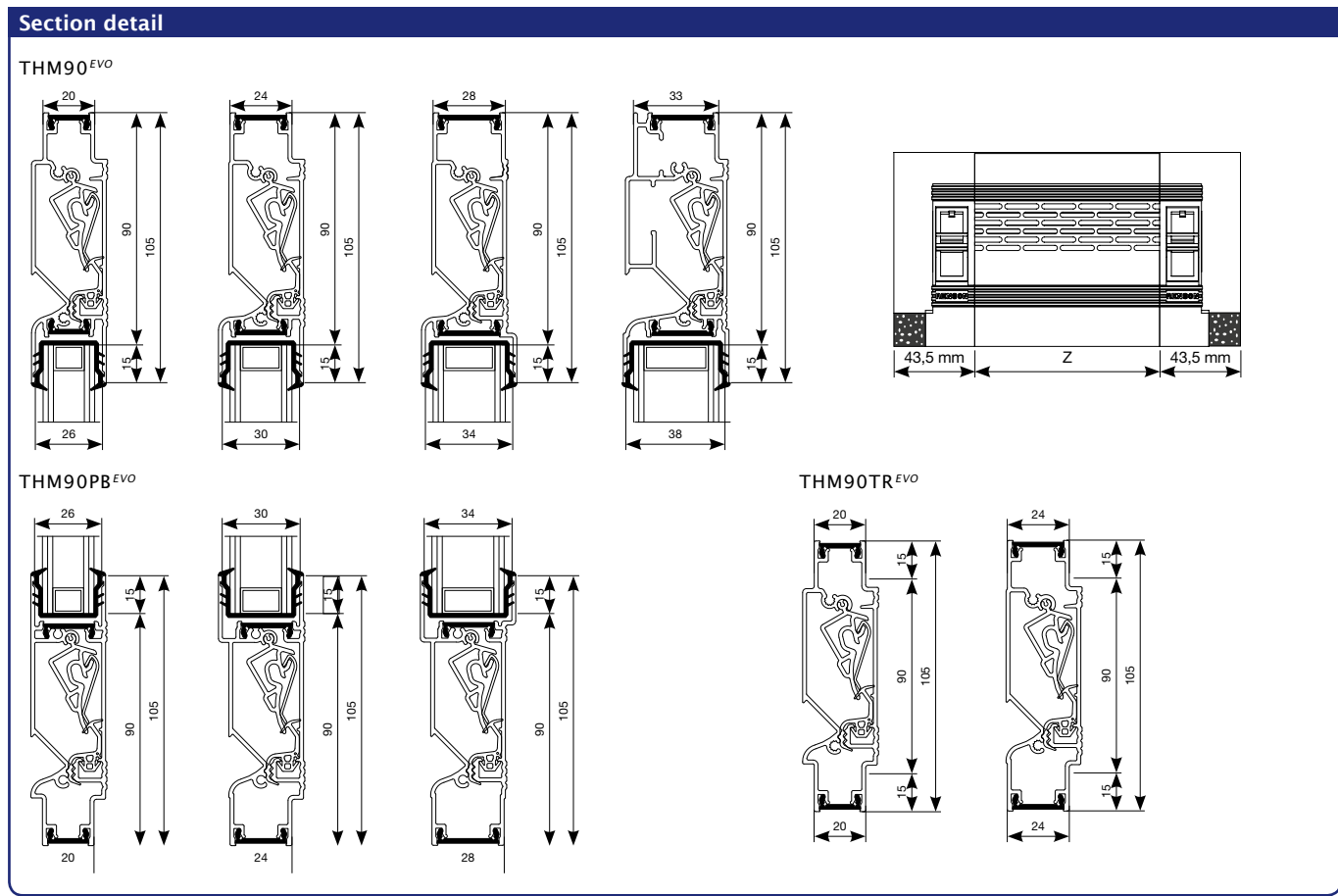

Technical characteristics		THM90 ^{EVO} - THM90PB ^{EVO} - THM90TR ^{EVO}
Airflow		
Equivalent area		11841 mm ² /m
Q at 1 Pa		9,3 l/s/m
Q at 1 Pa		33,5 m ³ /h/m
Q at 2 Pa		13,9 l/s/m
Q at 10 Pa		13,5 l/s/m
Q at 20 Pa		15,1 l/s/m
Comfort		
Sound reduction D _{n,e,w} (C;C _{tr})		
- In open positie		26 (0;0) dB
- In gesloten positie		45 (-1;-1) dB
Technical characteristics		
Controllable internal flap		5 stepped positions
Control options internal flap		Manual, cord, rod, motor
U value		3,8 W/m ² K
Air leakage at 50 Pa		<15% (in closed position)
Watertightness in closed position, up to		650 Pa
Watertightness in open position, up to		100 Pa
Dimensions		
Glass reduction		90 mm
Height		105 mm
Glass thickness		
THM90 ^{EVO}		20, 24, 28 or 33 mm
THM90PB ^{EVO}		20, 24 or 28 mm
THM90TR ^{EVO}		20 or 24 mm
Max. length		2500 mm (2000 mm for motorised control)



AK80^{EVO} - AK80 < Acoustic flap ventilators glazed-in/at transom

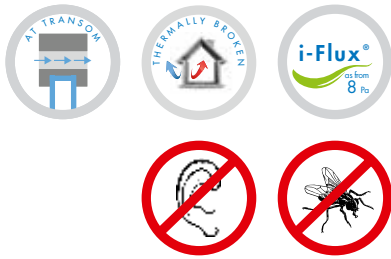

AK80^{EVO}: Compact, self-regulating acoustic window vent for installation at transom

The AK80^{EVO} is a thermally broken acoustic vent with a pleasing compact design. This ventilator is the self-regulating version of the AK80, and therefore ensures the supply of fresh and healthy air without any draughts.

Four different types are developed, each with their specific airflow and sound absorption. The AK80^{EVO}, which has a high isolation value, is typically installed at transom and suits for all window types (aluminium, wood, PVC).

Installation at transom

The AK80^{EVO} should preferably be installed at transom, and is applicable for aluminium, timber and PVC window frame types.

Thermally broken

No cold air transfer from outside to inside.

i-Flux®

Thanks to its self-regulating flap, the AK80^{EVO} ensures the supply of fresh and healthy air without draughts. The self-regulating flap only starts working at wind pressure of 8 Pa (instead of at 2 Pa). Moreover, the interior profile deflects the incoming air upwards, causing an optimal spread of fresh air in the room.

Sound absorbing

Various sound reduction levels (depending on the type), from 33 (-1;-2) dB up to 47 (0;-3)dB in open position.

Insect mesh

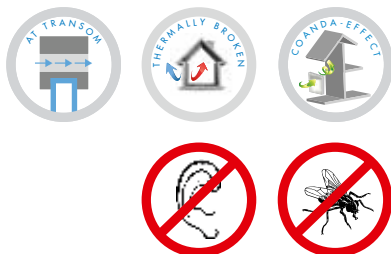

AK80: Compact non self-regulating acoustic window vent for installation at transom

The AK80 is a thermally broken acoustic vent with a pleasing compact design. Four different types are developed, each with their specific airflow and sound absorption. The AK80 is typically installed at transom.

Installation at transom

The AK80 should preferably be installed at transom, and is applicable for aluminium, timber and PVC window frame types.

Thermally broken

No cold air transfer from outside to inside.

Coanda effect

The interior profile deflects the incoming air upwards, causing an optimal spread of fresh air in the room.

Sound absorbing

Various sound reduction levels (depending on the type), from 33 (-1;-2) dB up to 47 (0;-3) dB in open position.

Insect mesh



Acoustic flap ventilators glazed-in/at transoms > AK80^{EVO} - AK80

Section detail

AK80^{EVO}

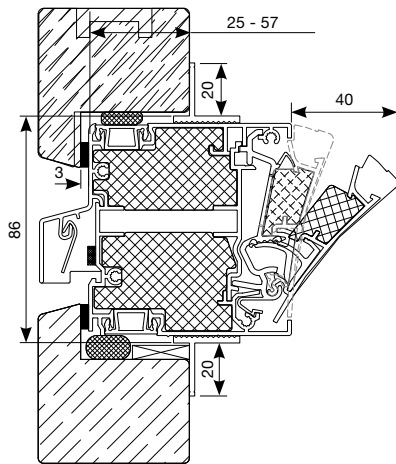

Endcap size = 32,5 mm

AK80

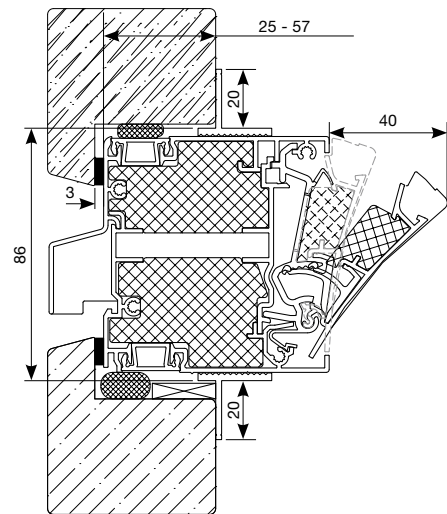

Endcap size = 32,5 mm

Technical characteristics	AK80 ^{EVO} /1	AK80 ^{EVO} /2	AK80 ^{EVO} /3	AK80 ^{EVO} /4
Airflow				
Equivalent area	n.p.d.	n.p.d.	n.p.d.	n.p.d.
Q at 1 Pa	0,6 l/s/m	0,9 l/s/m	1,3 l/s/m	4,1 l/s/m
Q at 1 Pa	2,0 m ³ /h/m	3,2 m ³ /h/m	4,7 m ³ /h/m	19,8 m ³ /h/m
Q at 2 Pa	1,1 l/s/m	1,7 l/s/m	2,1 l/s/m	6,6 l/s/m
Q at 10 Pa	3,5 l/s/m	5,4 l/s/m	6,6 l/s/m	20,5 l/s/m
Q at 20 Pa	3,7 l/s/m	5,8 l/s/m	6,3 l/s/m	19,6 l/s/m
Comfort				
Sound reduction D _{n,e,w} (C;C _{tr})				
- in open position	47 (0;-3) dB	44 (-1;-4) dB	41 (-1;-3) dB	33 (-1;-2) dB
- in closed position	51 (-1;-3)	n.p.d.	n.p.d.	n.p.d.
Technical characteristics				
Controllable internal flap	5 stepped positions			
Control options internal flap	Manual, cord, rod, motor			
U value	2,3 W/m ² K	2,3 W/m ² K	2,3 W/m ² K	2,1 W/m ² K
Air leakage at 50 Pa	<15% (in closed position)			
Watertightness in closed position, up to	650 Pa			
Watertightness in open position, up to	50 Pa			
Dimensions				
Height	80 mm (box height) / 126 mm (total height with flanges)			
Max. length	2000 mm (1250 mm for cord control)			

Technical characteristics	AK80/1	AK80/2	AK80/3	AK80/4
Airflow				
Equivalent area	1488 mm ² /m	2163 mm ² /m	2545 mm ² /m	8780 mm ² /m
Q at 1 Pa	1,2 l/s/m	1,7 l/s/m	2,0 l/s/m	6,9 l/s/m
Q at 1 Pa	4,2 m ³ /h/m	6,1 m ³ /h/m	7,2 m ³ /h/m	24,8 m ³ /h/m
Q at 2 Pa	1,6 l/s/m	2,5 l/s/m	2,9 l/s/m	9,7 l/s/m
Q at 10 Pa	3,6 l/s/m	5,8 l/s/m	7,1 l/s/m	21,1 l/s/m
Q at 20 Pa	5,0 l/s/m	8,4 l/s/m	10,4 l/s/m	29,6 l/s/m
Comfort				
Sound reduction D _{n,e,w} (C;C _{tr})				
- in open position	47 (0;-3) dB	44 (-1;-4) dB	41 (-1;-3) dB	33 (-1;-2) dB
- in closed position	51 (-1;-3) dB	n.p.d.	n.p.d.	n.p.d.
Technical characteristics				
Controllable internal flap	5 stepped positions			
Control options internal flap	Manual, cord, rod, motor			
U value	2,3 W/m ² K	2,3 W/m ² K	2,3 W/m ² K	2,1 W/m ² K
Air leakage at 50 Pa	<15% (in closed position)			
Watertightness in closed position, up to	650 Pa			
Watertightness in open position, up to	50 Pa			
Dimensions				
Height	80 mm (box height) / 126 mm (total height with flanges)			
Max. length	2000 mm (1250 mm for cord control)			

AK80GL < Acoustic flap ventilators glazed-in/at transom



Compact non self-regulating acoustic window vent for glazed-in installation

The AK80GL is a thermally broken acoustic vent with a pleasing compact design. Four different types are developed, each with their specific air-flow and sound absorption. The AK80GL is available for installation on glass or at transom (using the additional transom profiles).

Glazed-in installation or at transom

The AK80 is available for glazed-in installation, and can also be placed at transom. This vent is applicable for aluminium, timber and PVC window frame types.

Thermally broken

No cold air transfer from outside to inside.

Coanda effect

The interior profile deflects the incoming air upwards, causing an optimal spread of fresh air in the room.

Sound absorbing

Various sound reduction levels (depending on the type), from 33 (-1;-2) dB up to 47 (0;-3) dB in open position.

Insect mesh



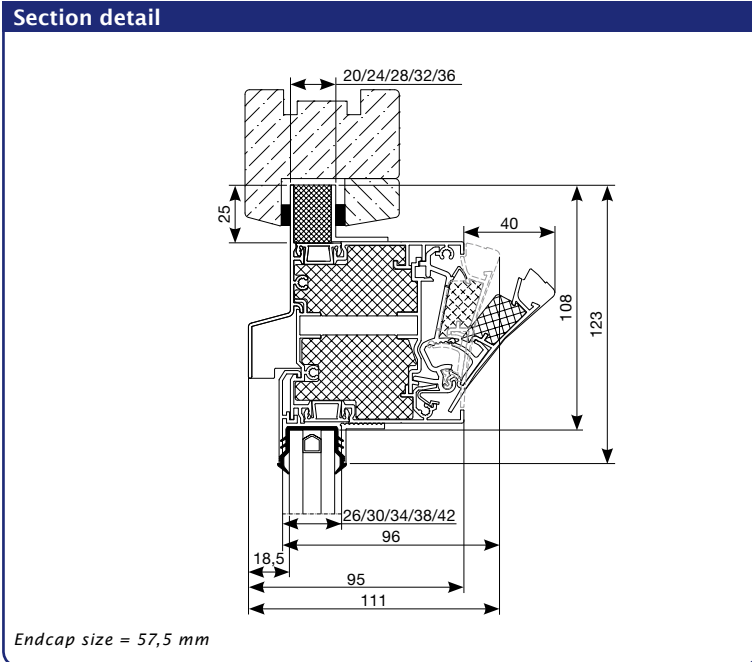

Technical characteristics	AK80GL/1	AK80GL/2	AK80GL/3	AK80GL/4
Airflow				
Equivalent area	1488 mm ² /m	2163 mm ² /m	2545 mm ² /m	8780 mm ² /m
Q at 1 Pa	1,2 l/s/m	1,7 l/s/m	2,0 l/s/m	6,9 l/s/m
Q at 1 Pa	4,2 m ³ /h/m	6,1 m ³ /h/m	7,2 m ³ /h/m	24,8 m ³ /h/m
Q at 2 Pa	1,6 l/s/m	2,5 l/s/m	2,9 l/s/m	9,7 l/s/m
Q at 10 Pa	3,6 l/s/m	5,8 l/s/m	7,1 l/s/m	21,1 l/s/m
Q at 20 Pa	5,0 l/s/m	8,4 l/s/m	10,4 l/s/m	29,6 l/s/m
Comfort				
Sound reduction D _{n,e,w} (C;C _{tr})				
- in open position	47 (0;-3) dB	44 (-1;-4) dB	41 (-1;-3) dB	33 (-1;-2) dB
- in closed position	51 (-1;-3) dB	n.b.	n.b.	n.b.
Technical characteristics				
Controllable internal flap	5 stepped positions			
Control options internal flap	Manual, cord, rod, motor			
U value	2,3 W/m ² K		2,1 W/m ² K	
Air leakage at 50 Pa	<15% (in closed position)			
Watertightness in closed position, up to	650 Pa			
Watertightness in open position, up to	50 Pa			
Dimensions				
Glass reduction	108 mm			
Height	80 mm (box height) / 123 mm (total height with flanges)			
Glass thickness	20, 24, 28, 32 or 36 mm			
Max. length	2000 mm (1250 mm for cord control)			

Sonovent® < Acoustic flap ventilators glazed-in/at transom



Self-regulating flap ventilator with a superior sound absorption

RENSON has developed the Sonovent range to meet with two aspects of living comfort:

- physical comfort: fresh and healthy air without draughts
- acoustic comfort: up to 56 dB sound reduction

The Sonovent is an extensive range of self-regulating window vents with a superior air sound insulation. Four types of the Sonovent are available; Small, Medium, Large and Xlarge, each model having 4 different air slot possibilities (10, 15, 20 or 25 mm). This comes up to 16 alternatives in total, each model with a different airflow and sound reduction. Furthermore, thermal breaks can be positioned differently, depending on the model and installation method. The Sonovent range therefore offers an ideal solution for every situation.

Glazed-in or at transom

The Sonovent is preferably placed at transom. By adding L-profiles to the upper and lower side, the Sonovent can also be placed on glass.

Thermally broken

No cold air-transfer from outside to inside. Thermal breaks can be positioned differently depending on the model and installation method.

Self-regulating

Thanks to its self-regulating flap, the Sonovent ensures the supply of fresh and healthy air without draughts.

Sound absorption

Various sound reduction levels (depending on the type), from 37dB up to 56 dB.

Insect mesh



The versatile Sonovent® - range

4 different models with different positions of the thermal break

- ➔ Models: **Small - Medium - Large - Xlarge**
- ➔ Thermal break: different positions **1 to 6**

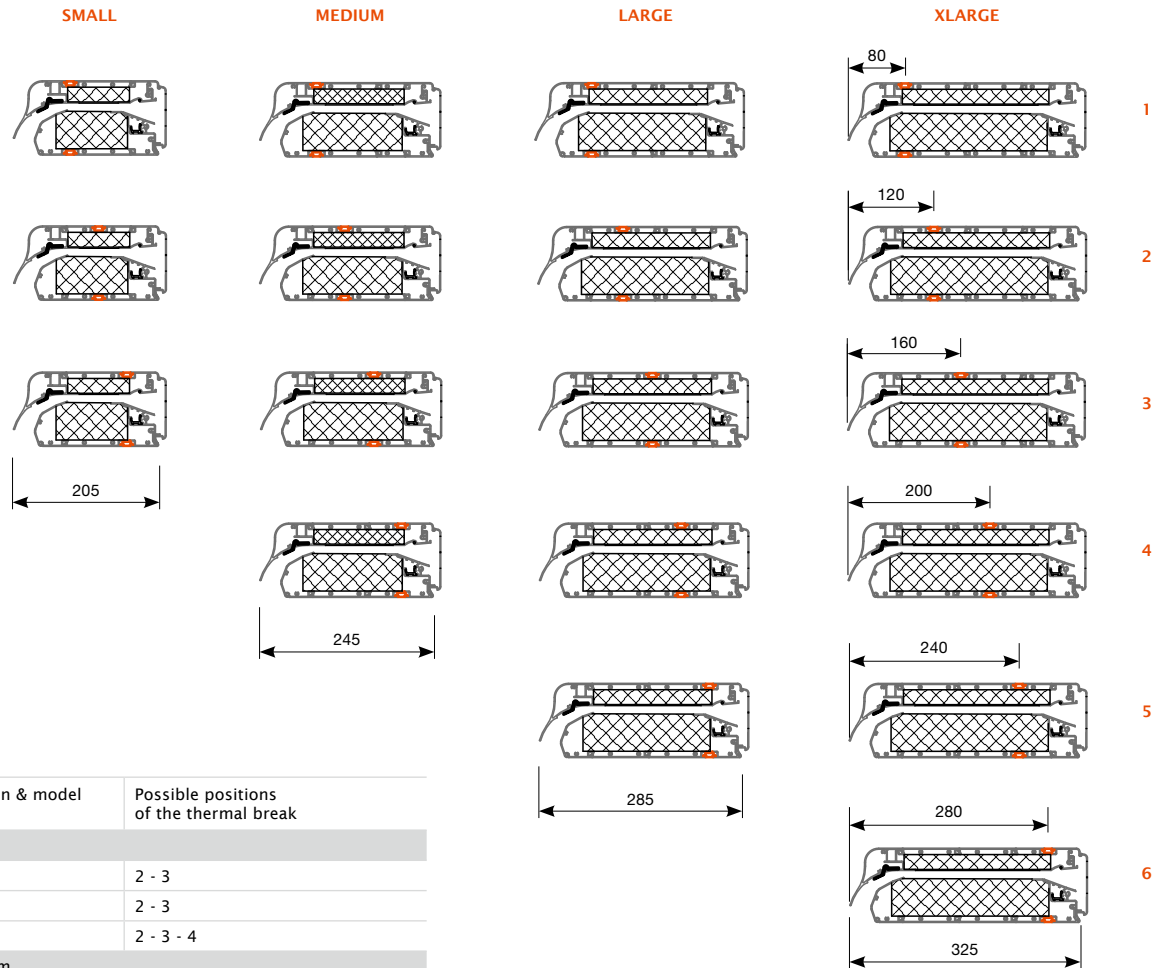

Installation & model	Possible positions of the thermal break
Glazed-in	
Small	2 - 3
Medium	2 - 3
Large	2 - 3 - 4
At transom	
Small	1 - 2 - 3
Medium	2 - 3 - 4
Large	2 - 3 - 4
Xlarge	2 - 3 - 4 - 5

- ➔ Airlot opening: **10 - 15 - 20 - 25 mm**

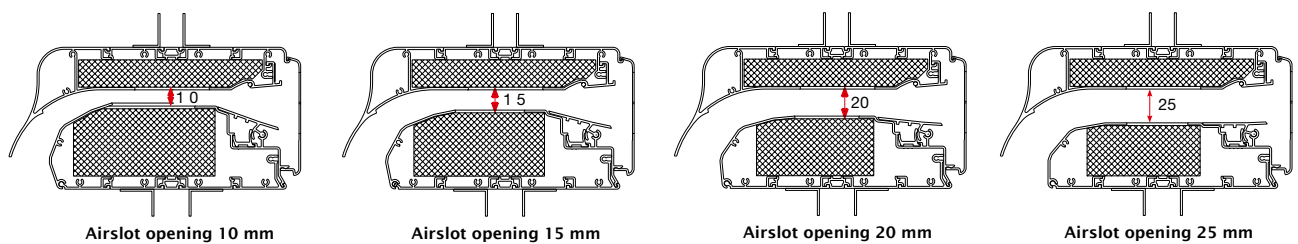

Sonovent® < Acoustic flap ventilators glazed-in/at transom

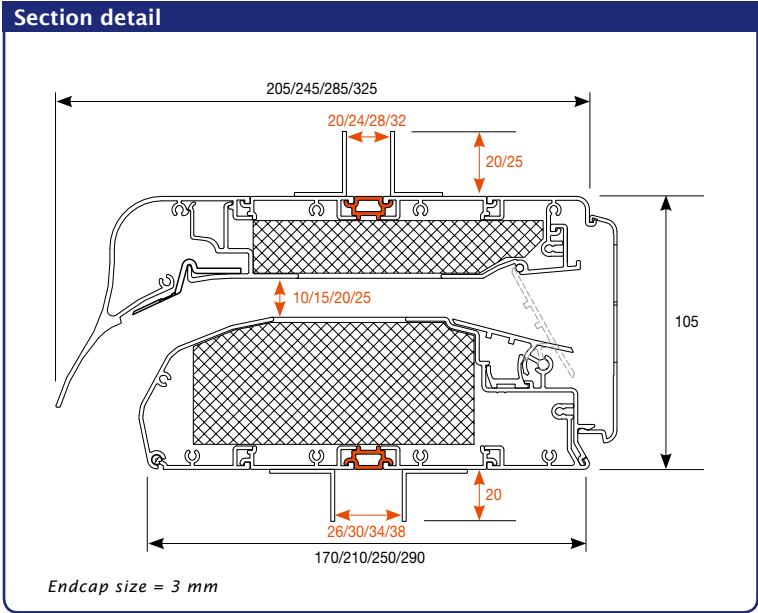

Installation

The Sonovent is designed to be installed glazed-in or at transom (preferred installation).

Hidden installation behind louvers or in a ventilated panel of a curtain wall system is also possible and commonly applied in offices, schools, ...

By choosing the right model of Sonovent and varying the length, the required airflow together with the necessary acoustic performances can be reached.

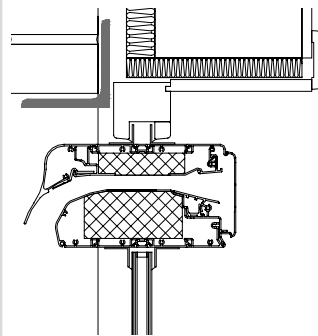

Glazed-in

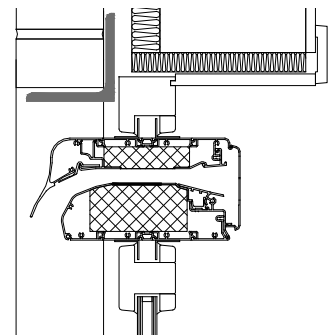

Fully glazed-in (at transom)
(recommended installation)

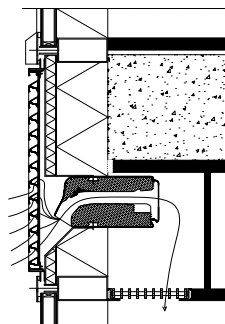

Hidden installation (behind louvers)

Acoustic flap ventilators glazed-in/at transom > Sonovent®

Technical characteristics	Sonovent®			
	Small	Medium	Large	Xlarge
Airflow				
Equivalent area				
Air slot 10 mm	17756 mm ² /m	17509 mm ² /m	16153 mm ² /m	14427 mm ² /m
Air slot 15 mm	29593 mm ² /m	26511 mm ² /m	25524 mm ² /m	21578 mm ² /m
Air slot 20 mm	31813 mm ² /m	33292 mm ² /m	32059 mm ² /m	31073 mm ² /m
Air slot 25 mm	33786 mm ² /m	34032 mm ² /m	33416 mm ² /m	32676 mm ² /m
Q at 1 Pa				
Air slot 10 mm	14,0 l/s/m	13,8 l/s/m	12,7 l/s/m	11,3 l/s/m
Air slot 15 mm	23,3 l/s/m	20,8 l/s/m	20,1 l/s/m	17,0 l/s/m
Air slot 20 mm	25,0 l/s/m	26,2 l/s/m	25,2 l/s/m	24,4 l/s/m
Air slot 25 mm	26,6 l/s/m	26,7 l/s/m	26,3 l/s/m	25,7 l/s/m
Q at 1 Pa				
Air slot 10 mm	50,2 m ³ /h/m	49,5 m ³ /h/m	45,7 m ³ /h/m	40,8 m ³ /h/m
Air slot 15 mm	83,7 m ³ /h/m	75,0 m ³ /h/m	72,2 m ³ /h/m	61,0 m ³ /h/m
Air slot 20 mm	90,0 m ³ /h/m	94,2 m ³ /h/m	90,7 m ³ /h/m	87,9 m ³ /h/m
Air slot 25 mm	95,6 m ³ /h/m	96,3 m ³ /h/m	94,5 m ³ /h/m	92,4 m ³ /h/m
Q at 2 Pa				
Air slot 10 mm	14,0 l/s/m	13,8 l/s/m	12,7 l/s/m	11,3 l/s/m
Air slot 15 mm	23,3 l/s/m	20,8 l/s/m	20,1 l/s/m	17,0 l/s/m
Air slot 20 mm	25,0 l/s/m	26,2 l/s/m	25,2 l/s/m	24,4 l/s/m
Air slot 25 mm	26,6 l/s/m	26,7 l/s/m	26,3 l/s/m	25,7 l/s/m
Q at 10 Pa				
Air slot 10 mm	15,3 l/s/m	15,1 l/s/m	14,0 l/s/m	12,5 l/s/m
Air slot 15 mm	25,6 l/s/m	22,9 l/s/m	22,1 l/s/m	18,7 l/s/m
Air slot 20 mm	27,5 l/s/m	28,8 l/s/m	27,7 l/s/m	26,9 l/s/m
Air slot 25 mm	29,2 l/s/m	29,4 l/s/m	28,9 l/s/m	28,2 l/s/m
Q at 20 Pa				
Air slot 10 mm	22,9 l/s/m	n.p.d.	n.p.d.	n.p.d.
Air slot 15 mm	28,5 l/s/m	n.p.d.	n.p.d.	n.p.d.
Air slot 20 mm	29,2 l/s/m	n.p.d.	n.p.d.	n.p.d.
Air slot 25 mm	27,1 l/s/m	27,5 l/s/m	25,0 l/s/m	n.p.d.
Comfort				
Sound reduction $D_{n,e,w}$ (C;C _{tr}) in open position				
Air slot 10 mm	46 (-1;-5) dB	48 (-2;-6) dB	50 (-2;-6) dB	56 (-2;-6) dB
Air slot 15 mm	41 (-1;-2) dB	45 (-2;-6) dB	49 (-2;-7) dB	53 (-2;-6) dB
Air slot 20 mm	40 (-1;-3) dB	43 (0;-3) dB	44 (-2;-6) dB	46 (-2;-6) dB
Air slot 25 mm	37 (-1;-3) dB	39 (-1;-4) dB	41 (-2;-6) dB	45 (-2;-6) dB
Sound reduction $D_{n,e,w}$ (C;C _{tr}) in closed position				
n.p.d.				
Technical characteristics				
Controllable internal flap	Continuous adjustment			
Control options internal flap	Manual, cord, rod, motor			
U value	4,5 W/m ² K	4,6 W/m ² K	4,6 W/m ² K	4,7 W/m ² K
Air leakage at 50 Pa	<15% (in closed position)			
Watertightness in closed position, up to	650 Pa			
Watertightness in open position, up to	50 Pa			
Dimensions				
Glass reduction	130 mm (flange 20 mm), 135 mm (flange 25 mm)			
Height	105 mm (total height with flanges: 145 or 150 mm)			
Glass thickness	20, 24, 28, 32 (or more upon request)			
Max. length	2000 mm (glazed-in installation) / 2500 mm (installation at transom)			
Depth/Total depth	170/205 mm (Small), 210/245 mm (Medium), 250/285 mm (Large) or 290/325 mm (Xlarge)			

Sonovent® Compact < Acoustic flap ventilators glazed-in/at transom



Compact self-regulating acoustic flap ventilator

The Sonovent Compact is a self-regulating and acoustic window vent for glazed-in installation (or at transom using an additional transom profile). This compact sound absorbing window vent offers an excellent compromise between acoustic performance and airflow. The Sonovent Compact has 3 different air slot possibilities (10, 13 or 15 mm), so three different airflows can be obtained within a single model.

Glazed-in installation (or at transom)

The Sonovent Compact can be installed glazed-in or at transom (using the additional transom profiles).

Thermally broken

No cold air transfer from outside to inside.

Self-regulating

Thanks to its self-regulating flap, the Sonovent Compact ensures the supply of fresh and healthy air without draughts.

Three different airflow levels in one model

The Sonovent Compact has 3 different air slot possibilities (10, 13 or 15 mm), so three different airflows can be obtained within a single model.

Sound absorption

Various sound reduction levels (depending on the type), from 33 dB up to 36 dB.

Insect mesh



Acoustic flap ventilators glazed-in/at transom > Sonovent® Compact

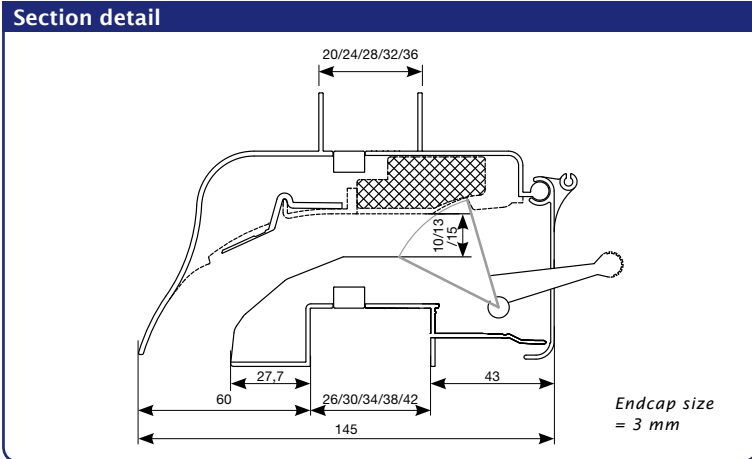

Technical characteristics	Sonovent® Compact
Airflow	
Equivalent area	
Air slot 10 mm	15334 mm ² /m
Air slot 13 mm	19278 mm ² /m
Air slot 15 mm	24687 mm ² /m
Q at 1 Pa	
Air slot 10 mm	12,1 l/s/m
Air slot 13 mm	15,2 l/s/m
Air slot 15 mm	19,4 l/s/m
Q at 1 Pa	
Air slot 10 mm	43,4 m ³ /h/m
Air slot 13 mm	54,5 m ³ /h/m
Air slot 15 mm	69,8 m ³ /h/m
Q at 2 Pa	
Air slot 10 mm	16,4 l/s/m
Air slot 13 mm	18,8 l/s/m
Air slot 15 mm	19,9 l/s/m
Q at 10 Pa	
Air slot 10 mm	17,3 l/s/m
Air slot 13 mm	18,8 l/s/m
Air slot 15 mm	18,6 l/s/m
Q at 20 Pa	
Air slot 10 mm	17,8 l/s/m
Air slot 13 mm	18,7 l/s/m
Air slot 15 mm	19,1 l/s/m
Comfort	
Sound reduction $D_{n,e,w}$ (C;C _{tr}) in open position	
Air slot 10 mm	36 (0;-1) dB
Air slot 13 mm	35 (0;-1) dB
Air slot 15 mm	33 (0;-1) dB
Sound reduction $D_{n,e,w}$ (C;C _{tr}) in closed position	
n.p.d.	
Technical characteristics	
Controllable internal flap	Continuous adjustment
Control options internal flap	Manual, cord, rod, motor
U value	6,0 W/m ² K
Air leakage at 50 Pa	<15% (in closed position)
Watertightness in closed position, up to	650 Pa
Watertightness in open position, up to	150 Pa
Dimensions	
Glass reduction	78 mm
Height	75 mm (box height) / 95 mm (total height with flanges)
Glass thickness	20, 24, 28, 32 or 36 mm
Max. length	2000 mm (glazed-in) or 2500 mm (at transom)



Sonovent® I < Acoustic flap ventilators glazed-in/at transom

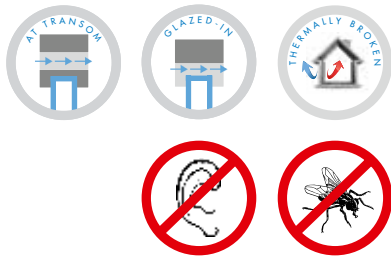

Flap ventilator with a superior sound absorption and increased airflow

The Sonovent I is a Sonovent with an increased airflow specifically designed for offices, commercial buildings and shops. Unlike the Sonovent, the Sonovent I is not self-regulating and the airtight opening is 36 mm resulting in an increased airflow.

Installation at transom (or glazed-in)

The Sonovent I is preferably placed at transom. By adding L-profiles to the upper and lower side, the Sonovent I can also be placed on glass.

Thermally broken

No cold air transfer from outside to inside. Thermal breaks can be positioned differently depending on the model and installation method.

Sound absorption

Various sound reduction levels (depending on the type), from 32 dB up to 36 dB.

Very high airflow

Up to 175,3 m³/h/m (Q at 2 Pa).

Insect mesh



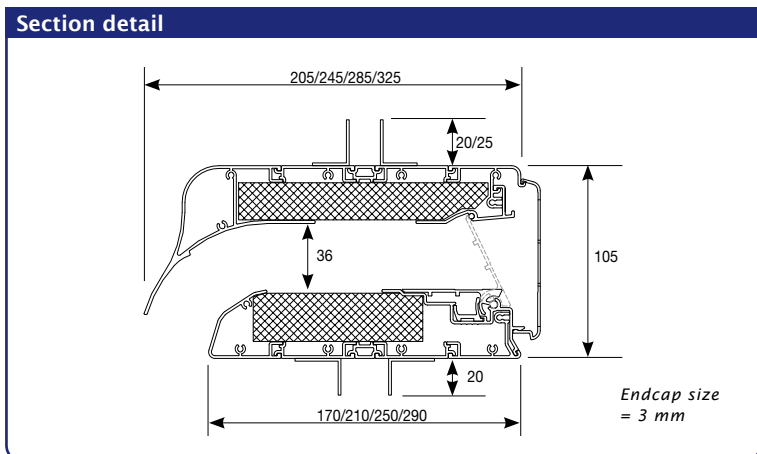

Technical characteristics	Sonovent® I			
	Small	Medium	Large	Xlarge
Airflow				
Equivalent area	43520 mm ² /m	44029 mm ² /m	43392 mm ² /m	43138 mm ² /m
Q at 1 Pa	34,2 l/s/m	34,6 l/s/m	34,1 l/s/m	33,9 l/s/m
Q at 1 Pa	123,1 m ³ /h/m	124,6 m ³ /h/m	122,8 m ³ /h/m	122,0 m ³ /h/m
Q at 2 Pa	48,2 l/s/m	48,7 l/s/m	48,0 l/s/m	48,0 l/s/m
Q at 10 Pa	107,8 l/s/m	107,1 l/s/m	107,3 l/s/m	107,3 l/s/m
Q at 20 Pa	152,4 l/s/m	150,5 l/s/m	151,8 l/s/m	151,8 l/s/m
Comfort				
Sound reduction D _{n,e,w} (C;C _{tr})				
- in open position	32 (-1;-3) dB	33 (-1;-3) dB	35 (-1;-4) dB	36 (-1;-4) dB
- in closed position	44 (-1;-4) dB	48 (-1;-5) dB	49 (-2;-5) dB	49 (-1;-5) dB
Technical characteristics				
Controllable internal flap	Continuous adjustment			
Control options internal flap	Motor			
U value	5,2 W/m ² K			
Air leakage at 50 Pa	<15% (in closed position)			
Watertightness in closed position, up to	650 Pa			
Watertightness in open position, up to	50 Pa			
Dimensions				
Glass reduction	130 mm (flange 20 mm), 135 mm (flange 25 mm)			
Height	105 mm (box height) / 145 mm or 150 mm (total height with flanges)			
Glass thickness	20, 24, 28 or 32 (or more upon request)			
Depth	170 mm	210 mm	250 mm	290 mm
Max. length	2000 mm (glazed-in) / 2500 mm (at transom)			



Sonovent® V < Acoustic flap ventilators glazed-in/at transom

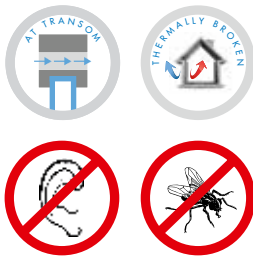

Mechanical ventilator with a superior sound absorption

Sonovent V is a mechanical ventilator with a compact radial fan which can produce up to 220 m³/h/m designed for non-residential applications. The Sonovent V can be used to mechanically supply or extract the room air (not suitable as kitchen or bathroom extractor). The ventilator starts to work automatically when fully opening the inner flap. The inner flap can be controlled manually or can be motorized. Thanks to acoustic insulation within this ventilator, the ventilator will reduce external soundlevels even when the fanmotor is switched on. The mechanical parts and the acoustic insulation are removable from the interior. It is possible to provide group control of up to 4 Sonovents, by wiring the fanmotors in parallel.

Installation at transom

The Sonovent V is designed for installation at transom only (not glazed-in).

Thermally broken

No cold air transfer from outside to inside.

Sound absorbing

35 (-1;-3) dB in open position

Insect mesh



Section detail

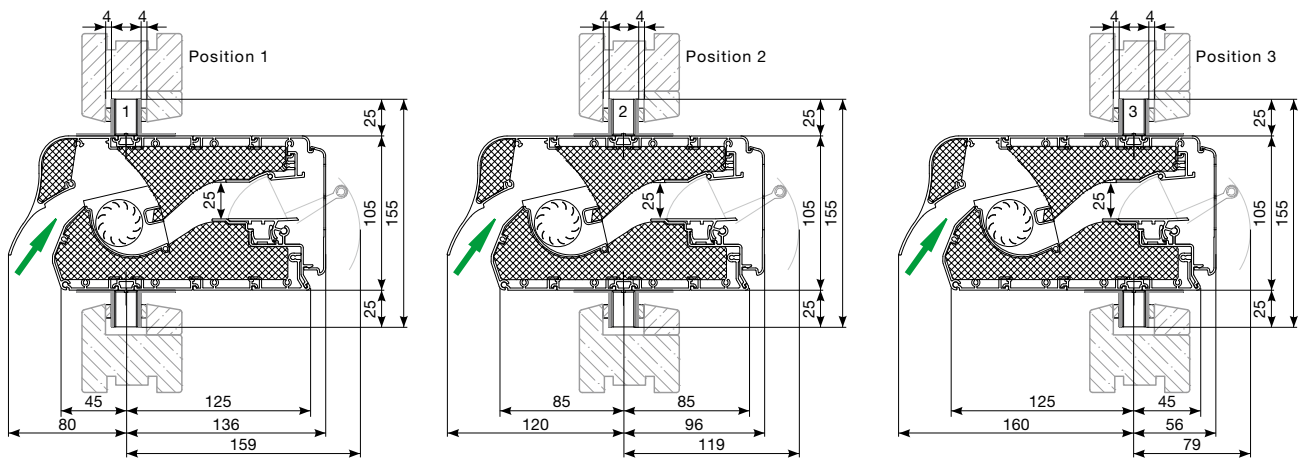

Supply

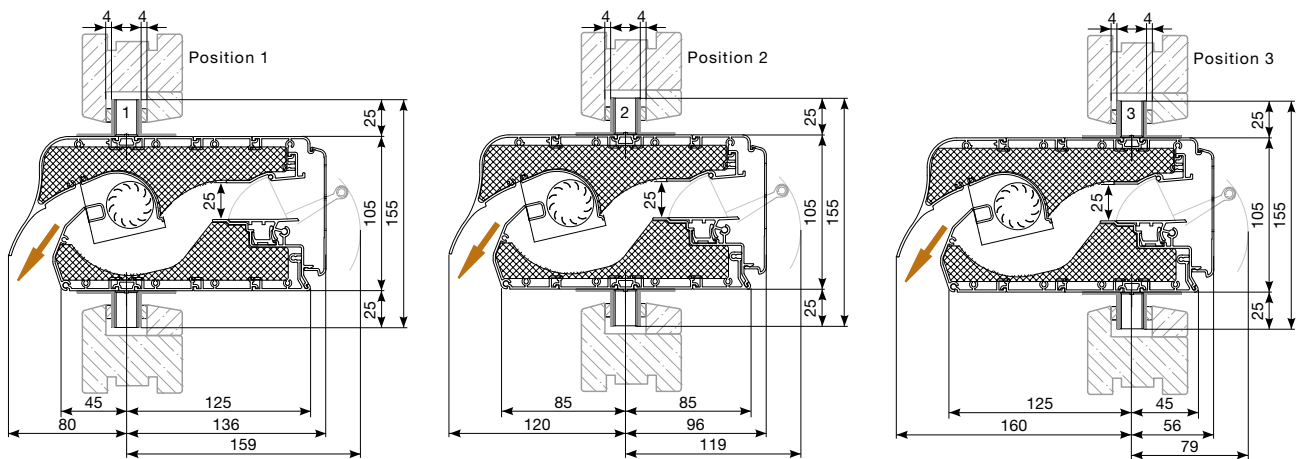

Extraction

Endcap size = 3 mm

Technical characteristics	Sonovent® V
Airflow	
Supply	61,11 l/s/m
Supply	220 m³/h/m
Extraction	61,11 l/s/m
Extraction	220 m³/h/m
Comfort	
Sound reduction $D_{n,e,w}$ (C;C _{tr})	
- in open position	35 (-1;-3) dB
- in closed position	n.p.d.
Technical characteristics	
Controllable internal flap	continuous
Control options internal flap	Manual, cord, rod, motor
U value	4,5 W/m²K
Air leakage at 50 Pa	n.p.d.
Watertightness in closed position, up to	650 Pa
Watertightness in open position, up to	n.p.d.
Fanmotor:	
- Powersupply	24 VDC
- Group control	up to 4 motors
Dimensions	
Height	105 mm (total height with flange profiles: 155 mm)
Glass thickness	20, 24, 28, 32 mm (other thicknesses available upon demand)
Max. length	2500 mm
Depth / Total depth	170 / 205 mm

Oxyvent® < Flap ventilator for conservatories



Natural extraction for conservatories

The Oxyvent is placed in the highest and warmest point of the conservatory's roof. This favours the extraction of hot and humid air using natural convection. Ventilators placed in the lower part of the conservatory assure a natural supply of fresh air. This patented natural extraction system has been designed to prevent water infiltration (in normal conditions).

Control the temperature in a natural way

Thanks to natural convection, cool and fresh air is supplied through vents in the vertical glass wall, while warm and humid air is extracted through the Oxyvent.

Glazed-in installation or on sandwich panels

The Oxyvent suits for glazed-in installation and installation in structures with sandwich panels (with thicknesses of 28 up to 86 mm, by steps of 2 mm).

Slope

The Oxyvent can be mounted on any conservatory roof with a minimum gradient of 5° or on vertical walls.

Thermally broken

No cold air transfer from outside to inside.

Burglar proof

With the Oxyvent one no longer needs to open up windows in order to ventilate the conservatory, which avoids the risk of burglary.

Insect mesh



Section detail

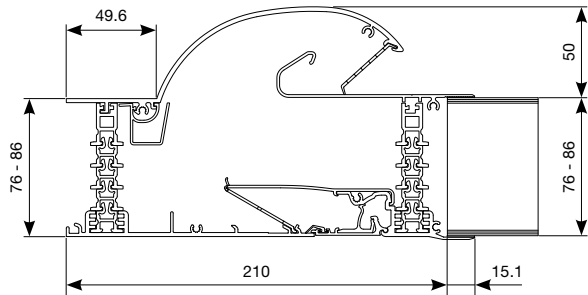
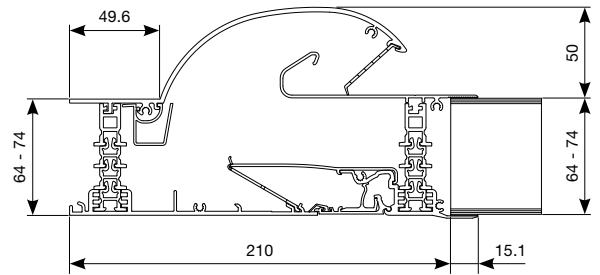
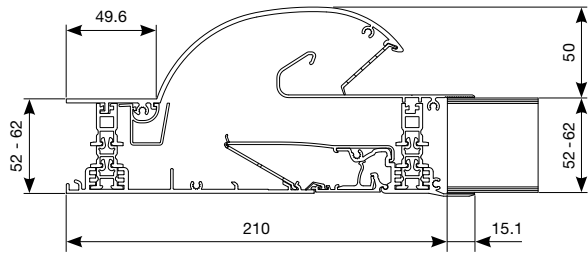
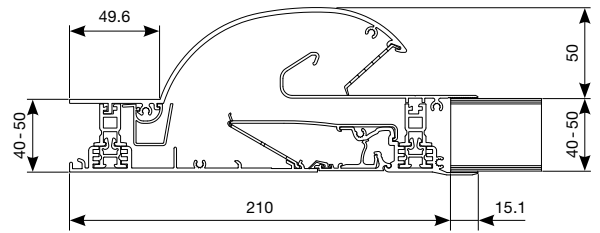
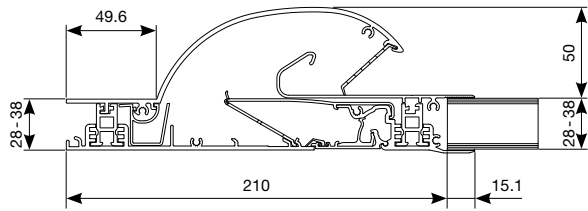

Endcap size = 55 mm

Technical characteristics	Oxyvent®
Airflow	
Equivalent area	15058 mm ² /m
Q at 1 Pa	11,8 l/s/m
Q at 1 Pa	42,6m ³ /h/m
Q at 2 Pa	16,7 l/s/m
Q at 10 Pa	37,42 l/s/m
Q at 20 Pa	52,9 l/s/m
Comfort	
Sound reduction D _{n,e,w} (C;C _v)	
- in open position	27 (-1;-2) dB
- in closed position	40 (0;-2) dB
Technical characteristics	
Controllable internal flap	Continuous adjustment
Control options internal flap	Manual, rod, motor
U value	Up to 2,8 W/m ² K
Air leakage at 50 Pa	<15% (in closed position)
Watertightness in closed position, up to	650 Pa
Watertightness in open position, up to	50 Pa
Dimensions	
Glass reduction	210 mm
Height exterior cap	50 mm
Glass thickness	28, 32, 36 mm
Thickness glass / sandwich panel	28 - 86 mm (by steps of 2 mm)
Max. length	1500 mm
Slope	Min. gradient of 5° on vertical walls

Sonovent® D < Acoustic ventilator for slant roofs

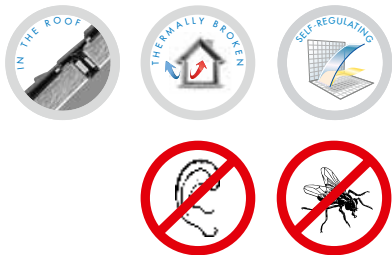

Self-regulating, acoustic ventilator for installation in rooms below slant roofs

The Sonovent D makes it possible to ventilate rooms below slant roofs, even if no windows are present. Moreover, thanks to its self-regulating flap, the Sonovent D ensures the supply of fresh and healthy air without draughts.

Installation in slant roofs

The Sonovent D has been developed for installation in slant roofs with a minimal slope of 22,5° in order to avoid water infiltration. Importantly, the entire length of the Sonovent D has to be covered with ventilation tiles.

Thermally broken

No cold air transfer from outside to inside.

Self-regulating

Thanks to its self-regulating flap, the Sonovent D ensures the supply of fresh and healthy air without draughts.

Sound absorption

Various sound reduction levels (depending on the type), up to 41 (-2;-6) dB.

Insect mesh



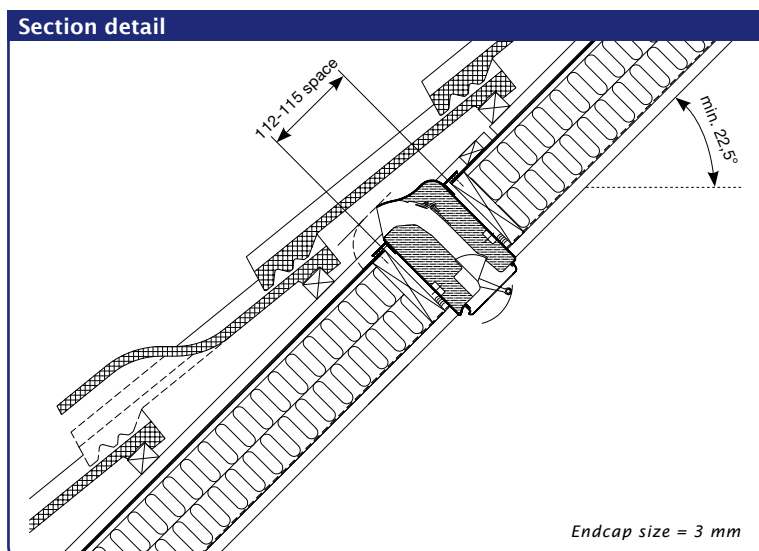

Technical characteristics	Sonovent® D		
	Small	Medium	Large
Airflow			
Equivalent area		31070 mm ² /m	
Q at 1 Pa		24,4 l/s/m	
Q at 1 Pa		87,9 m ³ /h/m	
Q at 2 Pa		28,0 l/s/m	
Q at 10 Pa		30,8 l/s/m	
Q at 20 Pa		34,8 l/s/m	
Comfort			
Sound reduction $D_{n,e,w}$ (C; C _{tr})			
- in open position	37 (-1;-3) dB	39 (-1;-4) dB	41 (-2;-6) dB
- in closed position		n.p.d.	
Technical characteristics			
Controllable internal flap		continuous adjustment	
Control options internal flap		Manual, cord, rod, motor	
U value	4,5 W/m ² K	4,6 W/m ² K	4,6 W/m ² K
Air leakage at 50 Pa		<15% (in closed position)	
Watertightness in closed position, up to		650 Pa	
Watertightness in open position, up to		100 Pa	
Dimensions			
Height	105 mm (box height) / 155 mm (total height with flanges)		
Roof thickness	170 mm	210 mm	250 mm
Minimal slope		22,5°	
Roof opening		115 mm	
Max. length		1000 mm	

Transivent® < Roller shutter flap ventilator

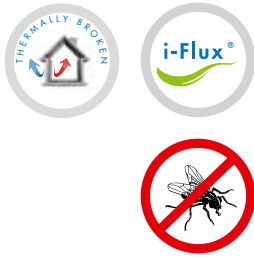

Self-regulating ventilator for installation in roller shutters

The Transivent is a self-regulating, thermally broken ventilator with an attractive design, for mounting in a traditional roller shutter housing. The curved aluminium inner profile deflects the incoming air upwards into the room.

The ideal solution for renovation

The Transivent, which can be easily integrated in roller shutters, has been developed for situations in which initially no ventilation solution has been foreseen, though in which ventilation is needed.

Thermally broken

No cold air transfer from outside to inside.

i-Flux®

Thanks to its self-regulating flap, the Transivent ensures the supply of fresh and healthy air without draughts. Moreover, the interior profile deflects the incoming air upwards, causing an optimal spread of fresh air in the room.

Insect mesh

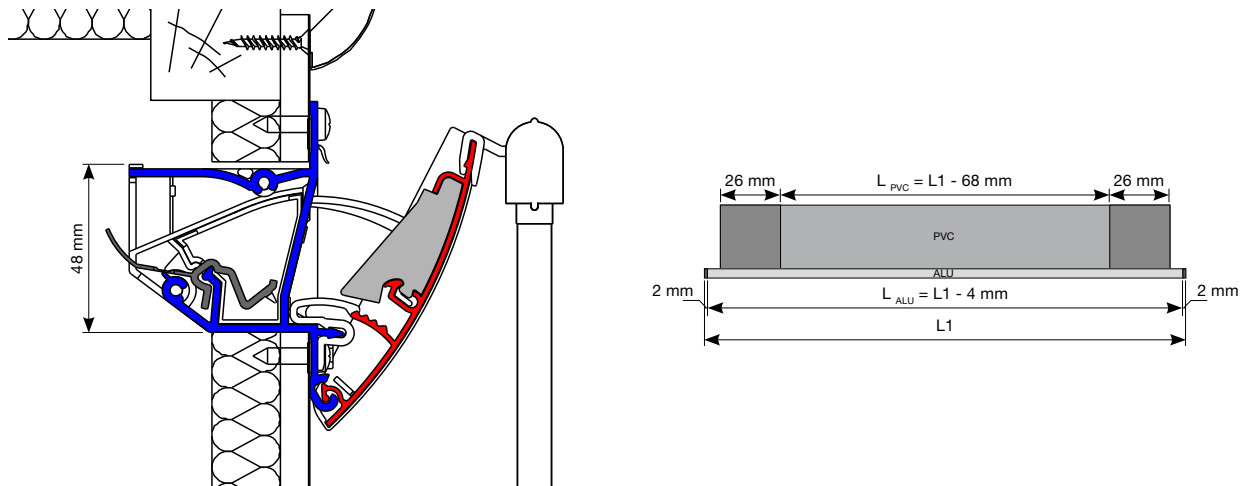

Section detail

Technical characteristics	Transivent®
Airflow	
Equivalent area	13748 mm ² /m
Q at 1 Pa	10,8 l/s/m
Q at 1 Pa	38,9 m ³ /h/m
Q at 2 Pa	15,2 l/s/m
Q at 10 Pa	20,1 l/s/m
Q at 20 Pa	19,9 l/s/m
Comfort	
Sound reduction D _{n,e,w} (C;C _{tr})	
- in open position	28 (-1;-2) dB
- in closed position	44 (-1;-2) dB
Technical characteristics	
Controllable internal flap	5 stepped positions
Control options internal flap	Manual, cord, rod, motor
U value	3,0 W/m ² K
Air leakage at 50 Pa	<15% (in closed position)
Watertightness in closed position, up to	650 Pa
Watertightness in open position, up to	150 Pa
Dimensions	
Installation height	91 mm
Fitted height	48 mm
Slot height	50 mm
Depth	60 mm
Max. length	2200 mm (1500 mm for cord control)

THL100 – THL100V < Sliding vents

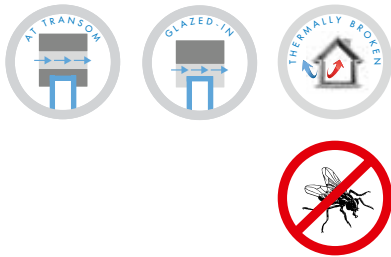

THL100: Horizontal sliding vent

THL100V: Vertical sliding vent

The THL100 is a thermally broken louvred ventilator, made to measure, installed in a vertical (THL100V) or horizontal (THL100) position. The THL100V creates a natural air circulation: incoming fresh air at the bottom and outgoing humid warm air at the top of the ventilator.

Glazed-in installation or installation at transom

THL100 or THL100V for glazed-in installation (glass thickness 15, 20, 24, 28 mm)

THL100-TR or THL100V-TR for installation at transom (glass thickness 20, 24, 28 mm)

Not suitable for installation in coastal environments or near the beach.

Thermally broken

No cold air transfer from outside to inside.

Louvres at the outside, a slider at the inside

Insect mesh

Easy and efficient



Section detail

THL100

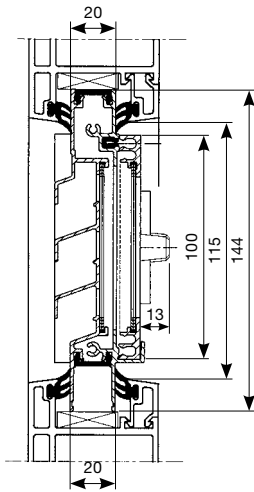

Endcap size = 22 mm

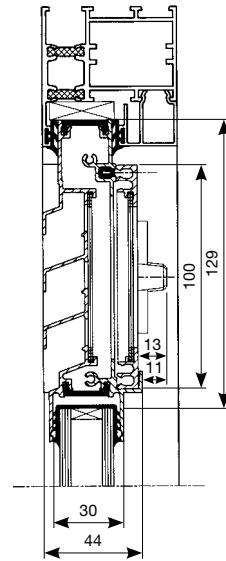

THL100 V

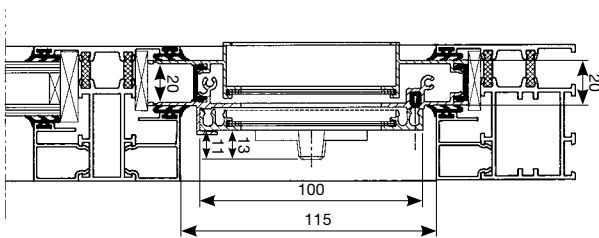

Endcap size = 22 mm

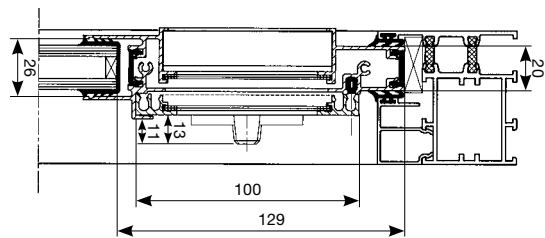

Technical characteristics	THL100	THL100V
Airflow		
Equivalent area	16759 mm ² /m	12770 mm ² /m
Q at 1 Pa	13,2 l/s/m	10,0 l/s/m
Q at 1 Pa	47,4 m ³ /h/m	36,1 m ³ /h/m
Q at 2 Pa	18,7 l/s/m	14,2 l/s/m
Q at 10 Pa	41,6 l/s/m	32,1 l/s/m
Q at 20 Pa	58,9 l/s/m	45,5 l/s/m
Comfort		
Sound reduction $D_{n,e,w}$ (C;C _{tr})		
- in open position	22 (0;-1) dB	
- in closed position	42 (-1;-2) dB	
Technical characteristics		
Controllable internal flap	Continuous adjustment	
Control options internal flap	Manual, cord, rod, chain, motor	
U value	3,9 W/m ² K	
Air leakage at 50 Pa	n.p.d.	
Watertightness in closed position, up to	400 Pa	
Watertightness in open position, up to	n.p.d.	
Dimensions		
Glass reduction	129 mm	
Height	144 mm	
Glass thickness	15*, 20, 24 or 28 mm	
Max. length	3500 mm	

* not for installation at transom

T67 - T100 - T130 - T150 < Sliding vents



T67 - T100 - T130 - T150

Horizontal sliding vents in two parts for installation at transom

The T67, T100, T130 en T150 are aluminium sliding vents without thermal break, to be installed at transom. These types are composed of two unattached parts; the outer part is a decorative louvre with inclined blades to ensure rain protection, the inside part is an aluminium slider that can be adjusted to control the airflow.

Not suitable for installation in coastal environments or near the beach.

Installation at transom

The T67, T100, T130 en T150 can be installed at transom.

Insect mesh



Sliding vents > T67 - T100 - T130 - T150

Section detail

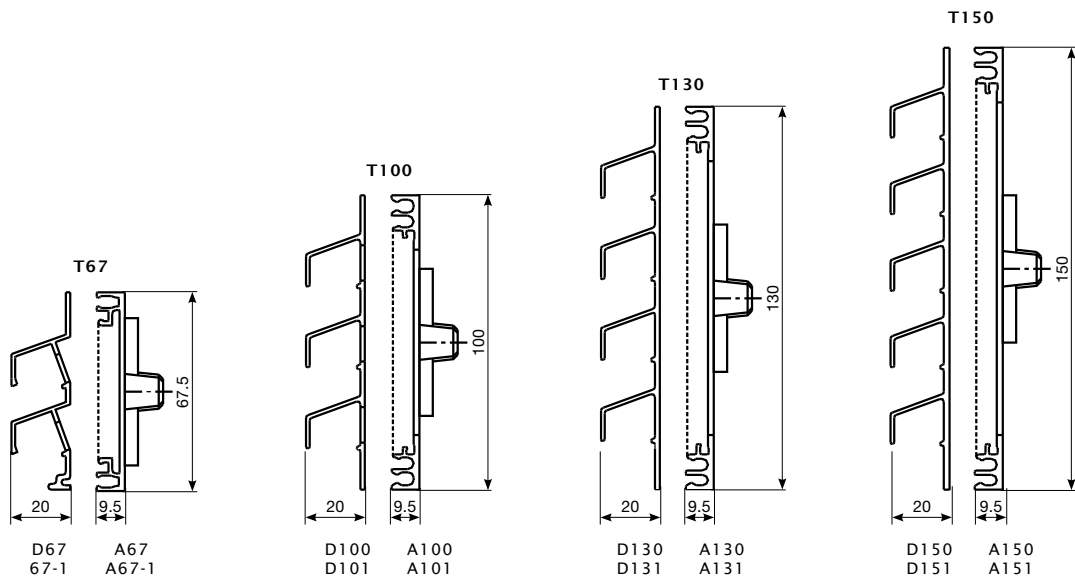

Endcap size = 1,5 mm

Technical characteristics	T67	T100	T130	T150
Airflow				
Equivalent area	11224 mm ² /m	17326 mm ² /m	24589 mm ² /m	27992 mm ² /m
Q at 1 Pa	8,8 l/s/m	13,6 l/s/m	19,3 l/s/m	22,0 l/s/m
Q at 1 Pa	31,8 m ³ /h/m	49,0 m ³ /h/m	69,6 m ³ /h/m	79,2 m ³ /h/m
Q at 2 Pa	12,7 l/s/m	19,5 l/s/m	27,7 l/s/m	31,9 l/s/m
Q at 10 Pa	28,5 l/s/m	43,8 l/s/m	62,1 l/s/m	71,5 l/s/m
Q at 20 Pa	40,2 l/s/m	61,9 l/s/m	87,9 l/s/m	101,0 l/s/m
Comfort				
Sound reduction $D_{n,e,w}$ (C;C _{tr})				
- in open position			n.p.d.	
- in closed position			n.p.d.	
Technical characteristics				
Controllable internal flap		Continuous adjustment		
Control options internal flap	Manual, chain, cord	Manual, chain, cord, rod, motor		
U value		n.p.d.		
Air leakage at 50 Pa		n.p.d.		
Watertightness in closed position, up to		n.p.d.		
Watertightness in open position, up to		n.p.d.		
Dimensions				
Height	67 mm	100 mm	130 mm	150 mm
Max. length	3500 mm			

TL67 – TL100 – TL100 PB < Sliding vents

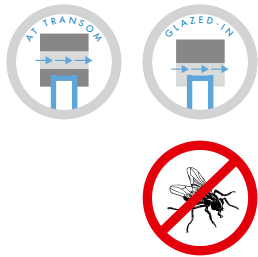

Sliding vents without thermal break for glazed-in installation or at transom

The TL67 en TL100(PB) are aluminium sliding vents without thermal break, typically for glazed-in installation. The outer part is a decorative louvre with inclined blades to ensure rain protection, the inside part is an aluminium slider which can be adjusted to control the airflow.

The THL100PB is a special version of the TL100 for installation at the bottom of the window.

Not suitable for installation in coastal environments or near the beach.

Glazed-in installation

The TL67 en TL100(PB) can be installed glazed-in (at the top of the glazing or at the bottom of the glazing: TL100PB), or at transom (using the additional transom profiles).

Insect mesh



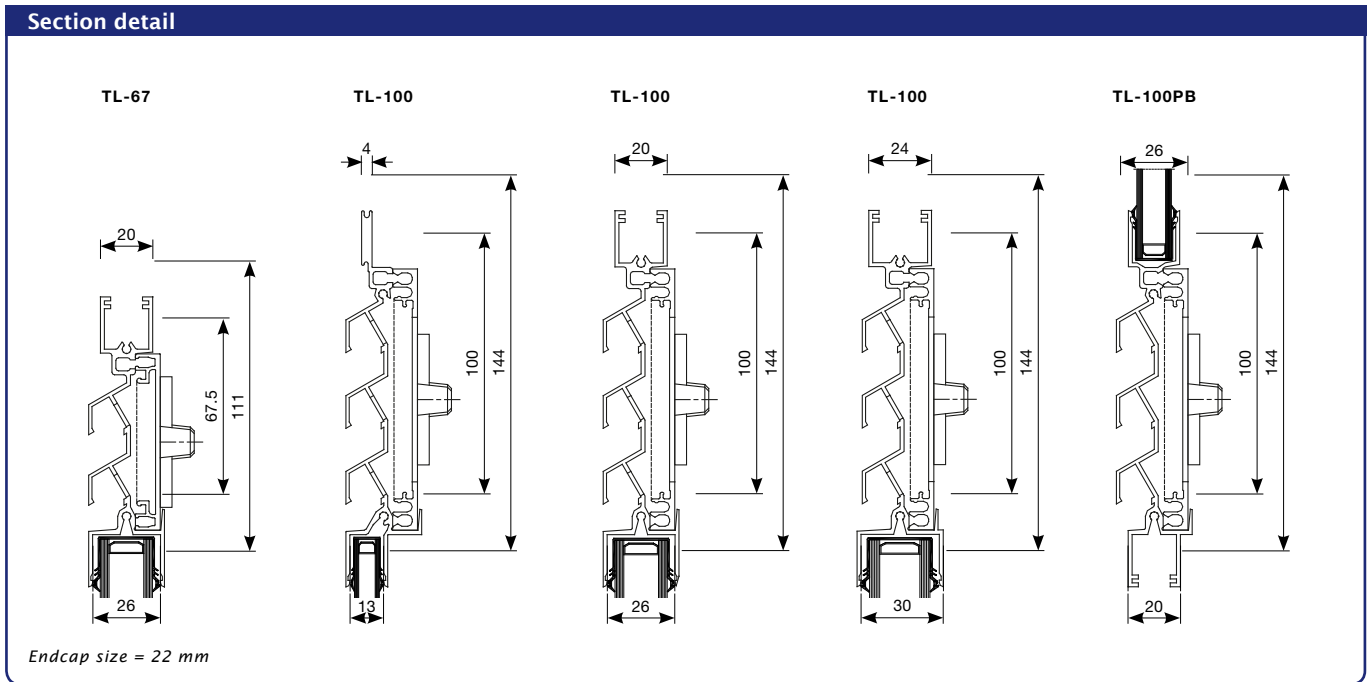

Technical characteristics	TL67	TL100	TL100PB
Airflow			
Equivalent area	10137 mm ² /m	14198 mm ² /m	14198 mm ² /m
Q at 1 Pa	8,0 l/s/m	11,2 l/s/m	11,2 l/s/m
Q at 1 Pa	28,7 m ³ /h/m	40,2 m ³ /h/m	40,2 m ³ /h/m
Q at 2 Pa	11,4 l/s/m	16,0 l/s/m	16,0 l/s/m
Q at 10 Pa	25,3 l/s/m	35,8 l/s/m	35,8 l/s/m
Q at 20 Pa	36,2 l/s/m	50,6 l/s/m	50,6 l/s/m
Comfort			
Sound reduction D _{n,e,w} (C;C _{tr})			
- in open position		n.p.d.	
- in closed position		n.p.d.	
Technical characteristics			
Controllable internal flap	Manual, chain, cord		Continuous adjustment
Control options internal flap	Manual, chain, cord		Manual, chain, cord, rod, motor
U value		n.p.d.	
Air leakage at 50 Pa		n.p.d.	
Watertightness in closed position, up to		n.p.d.	
Watertightness in open position, up to		n.p.d.	
Dimensions			
Height	67 mm	100 mm	100 mm
Glass reduction	98 mm	129 mm	129 mm
Glass thickness	20 mm	4, 20, 24 mm	20 mm
Max. length		3500 mm	



RENSON® developed an extensive range of slotvents. The RENSON® slotvents are manufactured in aluminium, this to ensure the highest possible quality and durability. These aluminium slotvents can be powdercoated in any color making a perfect integration possible on wooden, uPVC and aluminium window frames. RENSON® proposes some standard lengths for the slotvents but most of the types can be made to measure.

Slotsize openings

Slotvents are installed on window frames where a slot (10, 12, 16 or 25 mm) is routed through the frame. For long slotvents, enforcement bridges must be taken into account between the gaps, in order to prevent weakening the window frame. When combining an exterior and an interior slotvent, use the smallest slotsize opening indicated (airflow might be affected).

Permanent slot ventilators for domestic fuel burning appliances

To comply with Building Regulations and British Standards specific permanent air vents are required to provide combustion air/relief air. This non-controllable airvent must allow air passage at all times. The ventilator must be fitted with apertures which prevent the entry of a 10 mm diameter ball, but allow the entry of a 5 mm diameter ball.

The canopy 587P is fitted with a flyscreen to suit the 5/10 mm diameter ball specification.

A proposed slotvent set, complying with BS5440 and having approval of British Gas Technology is:

exterior: 587P + interior: 587P (inverted, allowing the incoming air to be deflected upwards to avoid undue draughts).

Slotvents are not suitable for use in high rise applications.

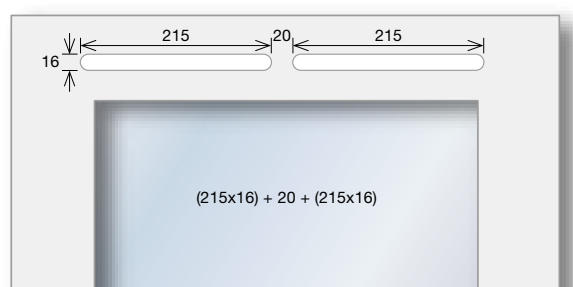
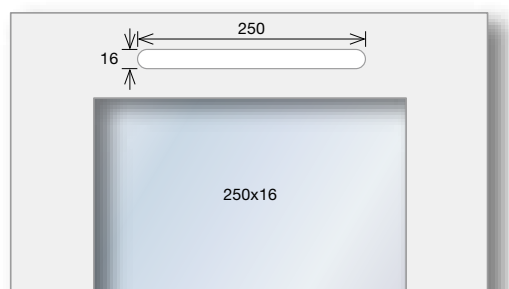



470 Sound absorbing box							
D _{n,e,w} (C;C _{tr}): 39 (-1;-1) dB							
Type	Length (mm)	Height (mm)	Slotsize opening (mm)	Airflow			
				1 Pa (l/s)	2 Pa (l/s)	2 Pa (m ³ /h)	Equivalent Area (mm ²)
470/30	400	45	(165 x 25) + 20 + (165 x 25)	1,4	2,0	7,3	1727
470/45	700	45	(315 x 25) + 20 + (315 x 25)	2,2	3,2	11,6	2831

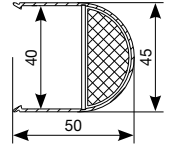

478 Flat grill							
Type	Length (mm)	Height (mm)	Slotsize opening (mm)	Airflow			
				1 Pa (l/s)	2 Pa (l/s)	2 Pa (m ³ /h)	Equivalent Area (mm ²)
478/1	275	20	230 x 16	1,9	2,8	9,9	2453
478/2	375	20	330 x 16	2,8	3,9	14,2	3512
478/3	475	20	(205 x 16) + 20 + (205 x 16)	3,7	5,4	19,3	4753
478/4	700	20	(315 x 16) + 25 + (315 x 16)	5,6	8,0	28,8	7119

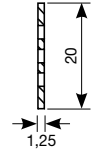

485 Hit and miss vent							
Type	Length (mm)	Height (mm)	Slotsize opening (mm)	Airflow			
				1 Pa (l/s)	2 Pa (l/s)	2 Pa (m ³ /h)	Equivalent Area (mm ²)
485/1	275	22	230 x 16	1,2	1,8	6,4	1551
485/2	375	22	330 x 16	1,9	2,7	9,9	2438
485/3	475	22	(210 x 16) + 20 + (200 x 16)	2,5	3,6	13,1	3214
485/4	700	22	(310 x 16) + 20 + (325 x 16)	4,1	6,0	21,6	5203

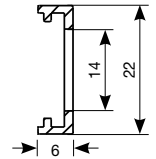

487 tipvent							
Type	Length (mm)	Height (mm)	Slotsize opening (mm)	Airflow			
				1 Pa (l/s)	2 Pa (l/s)	2 Pa (m ³ /h)	Equivalent Area (mm ²)
487/1	275	23	250 x 16	3,3	4,7	17,0	4229
487/2	375	23	(165 x 16) + 20 + (165 x 16)	4,8	6,8	24,4	6080
487/3	475	23	(215 x 16) + 20 + (215 x 16)	5,9	8,3	30,0	7496
487/4	700	23	(325 x 16) + 25 + (325 x 16)	9,8	14,0	50,5	12527

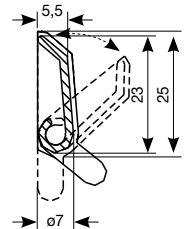

Interior slotvents < Slotvents

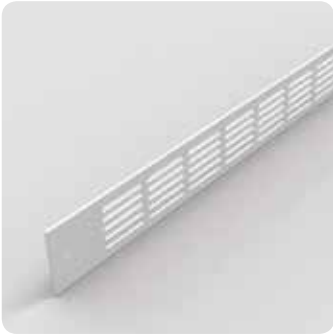

488		Patio grille					
Type	Length (mm)	Height (mm)	Slotsize opening (mm)	Airflow			
				1 Pa (l/s)	2 Pa (l/s)	2 Pa (m³/h)	Equivalent Area (mm²)
488/1	275	30	250 x 25	3,1	4,3	15,5	3899
488/2	375	30	(165 x 25) + 20 + (165 x 25)	4,3	5,9	21,4	5423
488/3	475	30	(215 x 25) + 20 + (215 x 25)	4,5	6,8	24,6	5787
488/4	700	30	(325 x 25) + 25 + (325 x 25)	8,5	12,1	43,5	10839

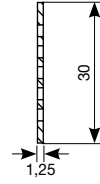

489		Bar grille					
Type	Length (mm)	Height (mm)	Slotsize opening (mm)	Airflow			
				1 Pa (l/s)	2 Pa (l/s)	2 Pa (m³/h)	Equivalent Area (mm²)
489/1	275	24	237 x 18	1,7	2,5	8,9	2202
489/2	375	24	337 x 18	2,2	3,2	11,7	2822
489/3	475	24	(210 x 18) + 17 + (210 x 18)	3,0	4,3	15,3	3807
489/4	700	24	(320 x 18) + 22 + (320 x 18)	5,1	7,2	25,8	6477

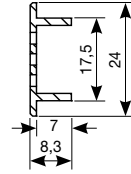

787AK		Tipvent					
Type	Length (mm)	Height (mm)	Slotsize opening (mm)	Airflow			
				1 Pa (l/s)	2 Pa (l/s)	2 Pa (m³/h)	Equivalent Area (mm²)
787AK/1	275	28	245 x 16	3,2	4,6	16,7	4127
787AK/2	375	28	345 x 16	4,0	5,7	20,5	5108
787AK/3	475	28	(215 x 16) + 20 + (215 x 16)	5,1	7,3	26,3	6525
787AK/4	700	28	(325 x 16) + 25 + (325 x 16)	9,0	12,9	46,5	11455

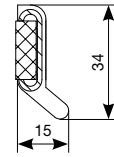

788P		Tipvent					
Type	Length (mm)	Height (mm)	Slotsize opening (mm)	Airflow			
				1 Pa (l/s)	2 Pa (l/s)	2 Pa (m³/h)	Equivalent Area (mm²)
788P/1	275	28	245 x 16	3,2	4,6	16,7	4127
788P/2	375	28	345 x 16	4,0	5,7	20,5	5108
788P/3	475	28	(215 x 16) + 20 + (215 x 16)	5,1	7,3	26,3	6525
788P/4	700	28	(325 x 16) + 25 + (325 x 16)	9,0	12,9	46,5	11455

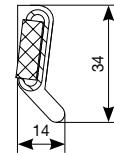

Slotvents > Exterior slotvents



471		Self regulating canopy						
Type	Length (mm)	Height (mm)	Slotsize opening (mm)	Airflow				
				1 Pa (l/s)	2 Pa (l/s)	2 Pa (m ³ /h)	Equivalent Area (mm ²)	
471/1	275	35	250 x 25	1,4	2,0	7,3	1785	
471/2	375	35	350 x 25	2,0	3,0	10,8	2527	
471/3	475	35	(215 x 25) + 20 + (215 x 25)	2,3	3,7	13,2	2951	
471/4	700	35	(325 x 25) + 25 + (325 x 25)	4,0	6,0	21,5	5055	

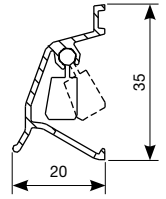

486		Canopy						
Type	Length (mm)	Height (mm)	Slotsize opening (mm)	Airflow				
				1 Pa (l/s)	2 Pa (l/s)	2 Pa (m ³ /h)	Equivalent Area (mm ²)	
486/1	275	35	250 x 25	1,7	2,4	8,5	2105	
486/2	375	35	350 x 25	2,2	3,2	11,4	2805	
486/3	475	35	(215 x 25) + 20 + (215 x 25)	3,2	4,6	16,5	4125	
486/4	700	35	(325 x 25) + 25 + (325 x 25)	4,4	6,2	22,5	5550	

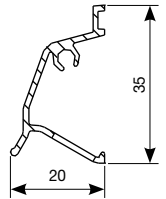

586		Canopy						
Type	Length (mm)	Height (mm)	Slotsize opening (mm)	Airflow				
				1 Pa (l/s)	2 Pa (l/s)	2 Pa (m ³ /h)	Equivalent Area (mm ²)	
586/1	275	28	250 x 25	3,3	4,8	17,2	4249	
586/2	375	28	350 x 25	4,3	6,2	22,4	5520	
586/3	475	28	(215 x 25) + 20 + (215 x 25)	6,4	9,0	32,5	8161	
586/4	700	28	(325 x 25) + 25 + (325 x 25)	8,9	12,8	46,2	11335	

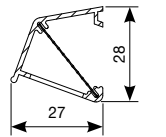

Exterior slotvents < Slotvents



587P		Canopy					
Type	Length (mm)	Height (mm)	Slotsize opening (mm)	Airflow			
				1 Pa (l/s)	2 Pa (l/s)	2 Pa (m³/h)	Equivalent Area (mm²)
587P/1	275	28	250 x 25	3,4	4,8	17,4	4312
587P/2	375	28	350 x 25	4,9	6,9	24,8	6210
587P/3	475	28	(215 x 25) + 20 + (215 x 25)	6,6	9,2	33,2	8354
587P/4	700	28	(325 x 25) + 25 + (325 x 25)	9,4	13,3	48,0	12015

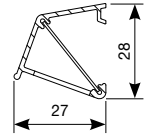

590		Clip in canopy					
Type	Length (mm)	Height (mm)	Slotsize opening (mm)	Airflow			
				1 Pa (l/s)	2 Pa (l/s)	2 Pa (m³/h)	Equivalent Area (mm²)
590/6	290	28	284 x 16	3,5	5,0	18,1	4498
590/7	470	28	(222 x 16) + 20 + (222 x 16)	6,1	8,7	31,2	7800
590/8	565	28	(270 x 16) + 19 + (270 x 16)	7,1	10,1	36,4	9067

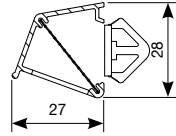

771AK		Acoustic canopy D _{n,e,w} (C;C _{tr}): 36 (-1;-1) dB					
Type	Length (mm)	Height (mm)	Slotsize opening (mm)	Airflow			
				1 Pa (l/s)	2 Pa (l/s)	2 Pa (m³/h)	Equivalent Area (mm²)
771AK/2	415	52	(165 x 25) + 20 + (165 x 25)	2,7	4,0	14,1	3372
771AK/3	565	52	(240 x 25) + 20 + (240 x 25)	4,8	6,9	24,8	6044
771AK/5*	565	52	(240 x 25) + 20 + (240 x 25)	4,9	7,0	25,2	6294

* without self-regulating flap

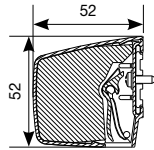

Sonoslot®
Self-regulating acoustic slotvent kit

The Sonoslot is a self-regulating, sound absorbing slotvent kit consisting of an external slotvent, internal slotvent and a plastic sleeve with integrated sound absorbing baffle in-between. The Sonoslot is available in 4 sizes: 275 mm, 375 mm, 475 mm and 700 mm.

The aluminium external slotvent is self-regulating. This keeps the airflow fairly uniform in strong winds and prevents draughts. The external slotvent is perforated and also acts as an insect mesh screen. The noise-damping baffle, made of sound absorbing foam, is standard 70 mm thick and the plastic sleeve is standard 90 mm thick, but both can be easily adapted to suit different window frame depths. The small, narrow and discrete aluminium internal slotvent can be completely closed. When open, it deflects the airflow upwards to prevent direct draughts. The Sonoslot is also available with permanently open clips.

i-Flux®

Thanks to the self-regulating flap in its exterior slotvent, the Sonoslot ensures the supply of fresh and healthy air without draughts. Moreover, the interior profile deflects the incoming air upwards, causing an optimal spread of fresh air in the room.

Sound absorbing

Sonoslot: up to 38 (0;0) dB in open position

Insect mesh

Endcap size (exterior): 17,5 mm
Endcap size (interior): 15 mm

Technical characteristics	Sonoslot® 275 mm	Sonoslot® 375 mm	Sonoslot® 475 mm	Sonoslot® 700 mm
Airflow				
Equivalent area	1273 mm ²	1607 mm ²	2121 mm ²	3181 mm ²
Q at 1 Pa	1,0 l/s	1,3 l/s	1,7 l/s	2,5 l/s
Q at 1 Pa	3,6 m ³ /h	4,5 m ³ /h	6,0 m ³ /h	9,0 m ³ /h
Q at 2 Pa	1,4 l/s	1,7 l/s	2,3 l/s	3,4 l/s
Q at 10 Pa	3,2 l/s	4,0 l/s	5,3 l/s	8,0 l/s
Q at 20 Pa	3,3 l/s	4,2 l/s	5,6 l/s	8,4 l/s
Comfort				
Sound reduction D _{n,e,w} (C;C _{tr})				
- in open position	38 (0;0) dB	37 (0;0) dB	36 (0;0) dB	34 (0;0) dB
- in closed position			n.p.d.	
Technical characteristics				
Controllable internal flap	Continuous adjustment			
Control options internal flap	Manual			
U value	1,4 W/m ² .K			
Air leakage at 50 Pa	< 15 % in closed position			
Watertightness in closed position, up to	n.p.d.			
Watertightness in open position, up to	n.p.d.			
Dimensions				
Height	35 mm			
Length	275 mm	375 mm	475 mm	700 mm
Slotsize opening	(105,5 x 16) + 24 + (105,5 x 16)	(105,5 x 16) + 14,3 + (105,5 x 16) + 14,3 + (105,5 x 16)	(105,5 x 16) + 7,5 + (105,5 x 16) + 7,5 + (105,5 x 16) + 7,5 + (105,5 x 16)	(105,5 x 16) + 7,5 + (105,5 x 16) + 7,5 + (105,5 x 16) + 7,5 + (105,5 x 16) + 7,5 + (105,5 x 16) + 7,5 + (105,5 x 16)
Length acoustic foam	2 x 103 mm	3 x 103 mm	4 x 103 mm	6 x 103 mm
Depth acoustic foam	70 mm			
Depth plastic sleeve	90 mm			



Endcap size (exterior): 17,5 mm
Endcap size (interior): 1,5 mm

Sonoslot® Max

Self-regulating slotvent kit with high acoustic damping

Sonoslot Max is a self-regulating slotvent kit offering a higher sound absorption than the Sonoslot, existing of an external slotvent, an internal slotvent and a plastic sleeve with integrated sound absorbing baffle in-between.

The aluminium external slotvent is self-regulating, which keeps the airflow fairly uniform in strong winds and prevents draughts. The external slotvent is perforated and also acts as an insect mesh screen. The noise-damping baffle is standard 70 mm thick and the plastic sleeve is standard 90 mm thick, but both can easily be adapted to suit different window frame depths.

This slotvent combination suits for all window depths. It can be used for both new-built and renovation projects.

Self-regulating

Thanks to the self-regulating flap in its exterior slotvent, the Sonoslot Max ensures the supply of fresh and healthy air without draughts.

Sound absorbing

Up to 40 (-1;-2) dB in open position.

Insect mesh

Technical characteristics	Sonoslot® Max	
	Without acoustic foam	With acoustic foam
Airflow		
Equivalent Area	2298 mm ²	1555 mm ²
Q at 1 Pa	1,8 l/s	1,2 l/s
Q at 1 Pa	6,5 m ³ /h	4,4 m ³ /h
Q at 2 Pa	2,7 l/s	1,9 l/s
Q at 10 Pa	6,8 l/s	5,1 l/s
Q at 20 Pa	6,9 l/s	7,6 l/s
Comfort		
Sound reduction $D_{n,e,w} (C;C_{tr})$		
- in open position	38 (-1;-2) dB	40 (-1;-2) dB
- in closed position		n.p.d.
Technical characteristics		
Controllable internal flap		no
Control options internal flap		n.a.
U value		n.p.d.
Air leakage at 50 Pa		n.p.d.
Watertightness in closed position, up to		n.p.d.
Watertightness in open position, up to		n.p.d.
Dimensions		
Height	35 mm (exterior part) / 45 mm (interior part)	
Length	700 mm	
Slotsize opening	(105,5 x 16) + 7,5 + (105,5 x 16) + 7,5 + (105,5 x 16) + 7,5 + (105,5 x 16) + 7,5 + (105,5 x 16) + 7,5 + (105,5 x 16)	
Length acoustic foam	n.a.	6 x 103 mm
Depth acoustic foam	n.a.	70 mm
Depth plastic sleeve		90 mm

Slotvent sets

Different slotvent combinations are possible. Hereby some proposed slotvent sets.

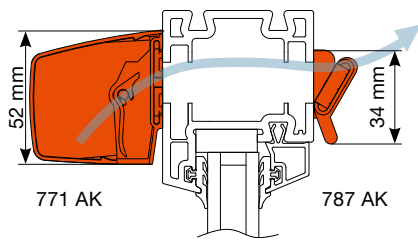
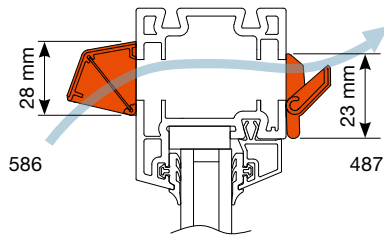

586 + 487

Airflow	1 Pa	2 Pa	2 Pa	Equivalent Area
586/1 + 487/1	2,3 l/s	3,4 l/s	12,1 m ³ /h	2968 mm ²
586/2 + 487/2	3,6 l/s	5,1 l/s	18,4 m ³ /h	4538 mm ²
586/3 + 487/3	4,6 l/s	6,6 l/s	23,6 m ³ /h	5874 mm ²
586/4 + 487/4	6,9 l/s	9,8 l/s	35,2 m ³ /h	8744 mm ²

771 AK + 787 AK D_{n,e,w} (C;C_{tr}): 40 (-1;-2) dB

Airflow	1 Pa	2 Pa	2 Pa	Equivalent Area
771 AK/2 + 787 AK/2	2,7 l/s	3,9 l/s	13,9 m ³ /h	3471 mm ²

Fixvent® Mono AK^{EVO} < Combined ventilation and sun shading overframe



The perfect combination of ventilation, windproof sun protection and insect resistance

RENSON® offers with the Fixvent Mono AK^{EVO} an aesthetical and comfortable solution which combines windproof sun protection, insect resistance and ventilation. The product, being installed overframe as a monobloc, offers several advantages:

- High thermal comfort:
 - solid U-values: up to 0,32 W/m²K (EXTREME- version)
- High visual comfort:
 - control of incoming light
 - maximal see-through to the external side even with the screen completely down
- High acoustic comfort:
 - different acoustic levels available offering a solution to every situation
- High aesthetical finish:
 - hidden installation with a maximal respect for the architecture: can be installed on aluminium, wood, uPVC windows in all possible window depths
 - hidden weld seam at the height of the bottom bar
 - large screen surfaces possible
- High physical comfort:
 - i-Flux technology: optimal comfort, minimal energy loss



The Fixvent Mono AK^{EVO} allows an easy and smooth overframe installation for window depths between 50 and 215 mm. Thanks to the patented Connect&Go- and Click&Safe-technology, an easy (dis)mounting of the screen tube can be guaranteed. The Fixscreen-technology provides a tight and windproof screen up to 130km/h. Then there is the Smooth-technology, which provides the zipper guides of a patented wear-resistant layer and makes the screen go up and down smoothly and silently.

Moreover thanks to the same “look & feel”, The Fixvent Mono AK^{EVO} can perfectly be combined with the Fixscreen Mono AK^{EVO}, which brings wind resistant sun shading and insect resistance together in one product.

The Fixvent range consists of:

Fixvent® Mono AK^{EVO}

- Ideal solution for new-build, (large) renovations and projects
- Constant supply of fresh and healthy air: self-regulating as from 2 Pa
- 3 levels of sound absorption in open position:
 - Fixvent Mono AK^{EVO}: up to 40 (-1;-4) dB
 - Fixvent Mono AK^{EVO} Ultra: up to 45 (-1;-5) dB
 - Fixvent Mono AK^{EVO} Extreme: up to 48 (-2;-5) dB

Fixvent® Mono UT^{EVO}

- Especially developed for utility buildings in which both the natural air supply and mechanical extraction are located in the same room
- Ideal solution for rooms with a high occupancy (as class rooms, offices, ...)
- Constant higher level of basic ventilation: self-regulation as from 10 Pa
- 2 levels of sound absorption in open position:
 - Fixvent Mono UT^{EVO}: up to 40 (-1;-4) dB
 - Fixvent Mono UT^{EVO} Ultra: up to 45 (-1;-5) dB
- No visual difference with Fixvent Mono AK^{EVO}

For further information: www.renson.eu

Combined ventilation and sun shading overframe > Fixvent® Mono AK^{EVO}

Section detail

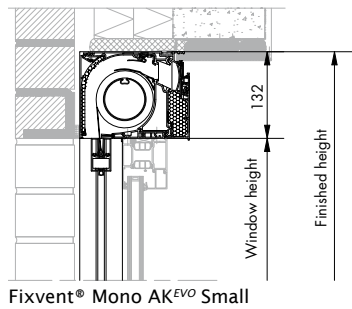

Technical characteristics	Small	Medium	Large	X-Large	XX-Large
Airflow					
Equivalent Area					
Fixvent® Mono AK ^{EVO}			18324 mm ² /m		
Fixvent® Mono AK ^{EVO} ULTRA			4836 mm ² /m		
Fixvent® Mono AK ^{EVO} EXTREME			2800 mm ² /m		
Fixvent® Mono UT ^{EVO}			19724 mm ² /m		
Fixvent® Mono UT ^{EVO} ULTRA			4836 mm ² /m		
Q at 1 Pa					
Fixvent® Mono AK ^{EVO}			12,8 l/s/m		
Fixvent® Mono AK ^{EVO} ULTRA			3,7 l/s/m		
Fixvent® Mono AK ^{EVO} EXTREME			2,1 l/s/m		
Fixvent® Mono UT ^{EVO}			15,5 l/s/m		
Fixvent® Mono UT ^{EVO} ULTRA			3,7 l/s/m		
Comfort					
Sound reduction $D_{new}(C;C_{tr})$ in open position (screen up)					
Fixvent® Mono AK ^{EVO}	33(0;-2)dB	35(0;-3)dB	36(-1;-4)dB	37(-1;-4)dB	40(-1;-4) dB
Fixvent® Mono AK ^{EVO} ULTRA	n.a.	38(0;-2)dB	40(-1;-4)dB	43(-1;-4)dB	45(-1;-5)dB
Fixvent® Mono AK ^{EVO} EXTREME	n.a.	43(0;-3)dB	43(0;-3)dB	46(-1;-4)dB	48(-2;-5)dB
Fixvent® Mono UT ^{EVO}	33(0;-2)dB	35(0;-3)dB	36(-1;-4)dB	37(-1;-4)dB	40(-1;-4) dB
Fixvent® Mono UT ^{EVO} ULTRA	n.a.	38(0;-2)dB	40(-1;-4)dB	43(-1;-4)dB	45(-1;-5)dB
Technical specifications					
Self-regulating at 2Pa	yes (UT-version at 10 Pa)				
Thermally broken	yes				
U-value (W/m²K)					
Fixvent® Mono AK ^{EVO}	1,47	0,98	0,80	0,77	0,72
Fixvent® Mono AK ^{EVO} ULTRA	n.a.	0,70	0,55	0,46	0,41
Fixvent® Mono AK ^{EVO} EXTREME	n.a.	0,62	0,47	0,38	0,32
Fixvent® Mono UT ^{EVO}	1,47	0,98	0,80	0,77	0,72
Fixvent® Mono UT ^{EVO} ULTRA	n.a.	0,70	0,55	0,46	0,41
Airflow leakage in closed position	< 15% at 50 Pa				
Insect mesh	yes				
Control					
Screen	motor control, manually (not for Ultra/Extreme)				
Ventilation flap	manually, rod, motor				
Dimensions					
Box					
Box height (mm)	132				
Box width (mm)	167	197	227	257	287
Compatible window depths (mm)	50-94	95-124	125-154	155-184	185-215
Screen: max. WxH (mm)+max. surface					
Single (1 screen - 1 control)	4000 x 3000 (12 m ² for motor control; 7,5 m ² for manual control)				
Coupled (2 parts - 2 motors)	6000 x 3000 (18 m ²)				
Bottom bar (DxH) (mm)	30 x 57				

Additional info < Epilogue

Glazing gaskets

RENSON advises the use of special designed glazing gaskets;

- Nr 019, colour: black, for glass thickness 36 – 40 – 44 mm
- Nr 029, colour: black, for glass thickness 28 – 36 mm
- Nr 034, colour: grey, for glass thickness 20 – 28 mm
- Nr 039, colour: black, for glass thickness 20 – 28 mm
- Nr 049, colour: black, for glass thickness 20 – 28 mm
- Nr 104, colour: black, for glass thickness 4 mm

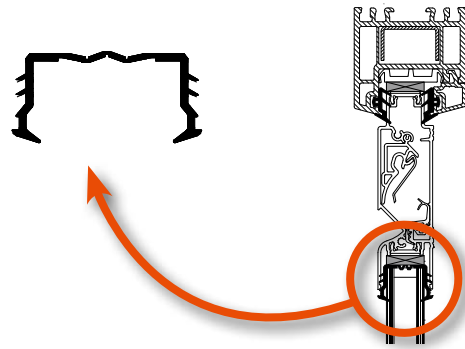

Controls

- Manual: possible through manually opening/closing of the flap (eg. Invisivent^{EVO} range), knob (e.g. THM90^{EVO}), lever (e.g. AR75). Standard lever is 30 mm, but longer levers (40, 50, 60 and 70 mm) are available upon request.

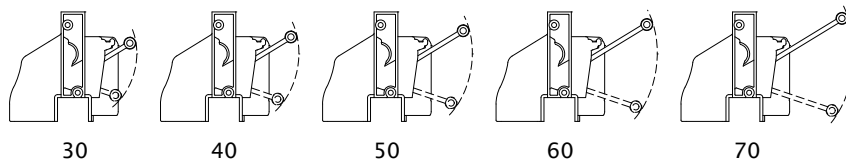

- Cord: standard length for cord control is 1000 mm, other dimensions are available upon request.
- Rod: standard length for rod control is 1000 mm, other dimensions are available upon request. The rod can be powdercoated in any RAL or Syntha Pulvin colour upon request. Also rod control with hook-up, with transmission and with sliding knob are available for certain vents (e.g. THM90^{EVO}).
- Motor: possible by means of an 'On/Off' or a '0-10V' (for home automation) switch. Standard cable length: 5m (except THL100(V), TL67-100-100PB, T67-100-130-150). The position of the cable exit for a Sonovent with motor control can be top left, top right, bottom left or bottom right.

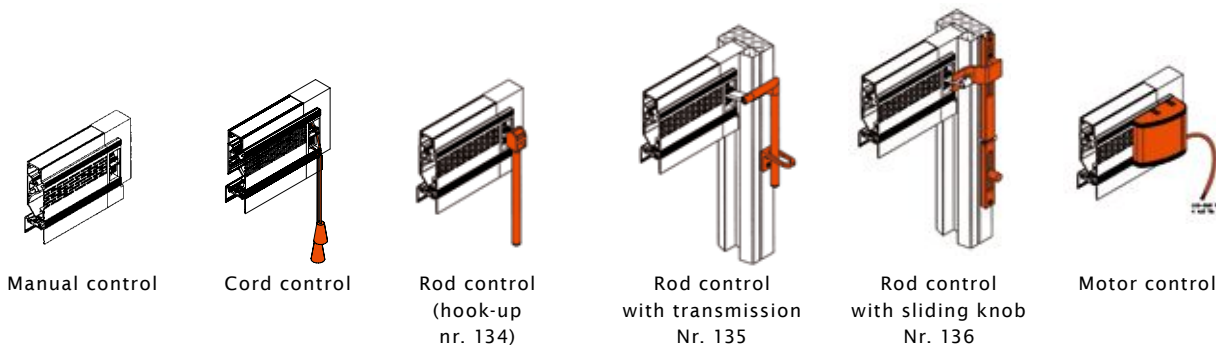

- Not all control options are possible for all vents.

Finishing

- Material internal and external profile: extruded AlMgSi 0.5 aluminium (according to EN 12020-2 and EN AW-6063)
- Finishing internal and external profile: bronze or satin anodized (E6/EV1-SAA, except for Oxyvent and Sonovent range) or powdercoated in any RAL or Syntha Pulvin colour (dual colour possible). Pre-treatment is recommended when used in an aggressive (in accordance with the standard Seaside Quality A) or a very aggressive (pre-anodisation) environment like sea-side, chemical industry, ...)
- Thermal bridge: extruded PVC (according to DIN 16941)
- Material end caps: ASA polymer type Luran S (colour-fast, weather- and UV-resistant)
- Colour end caps:

Overframe flap ventilators	available in any colour upon request (dual colour possible), dyed in the mass or painted
Other flap ventilators	black or white (and for AR75 also 1013, 1015, 7016, 7021, 7030, 7035, 7039, 8019, 9001, 9007), other colours available upon request
Sliding vents	black
Slot vents	black or white, depending on the type of slotvent

Maintenance

Almost all the RENSON window vents have a removable inner part for ease of maintenance.

Maintenance must be performed at least once a year. Clean the inside using a vacuum cleaner and/or damp cloth. Remove leaves and other dirt from the outside of the window vent. Clean the outside aluminium part with a damp cloth and a non-abrasive cleaner. Rinse the window vent thoroughly with clean water.

Transom Profiles

Two different transom profiles (height 35 mm or 62 mm) are available for the ventilators installed at transom. The transom profiles are developed for easy and swift fabrication from bar lengths and are also available made to measure. These profiles can be satin anodised or powdercoated in any RAL or Syntha Pulvin colour.

For the THM90^{EVO} RENSON developed special types which do not require transom profiles; the THM90PB^{EVO} for installation at the bottom of a window and the THM90TR^{EVO} for fully glazed-in installation between profiles (at transom).

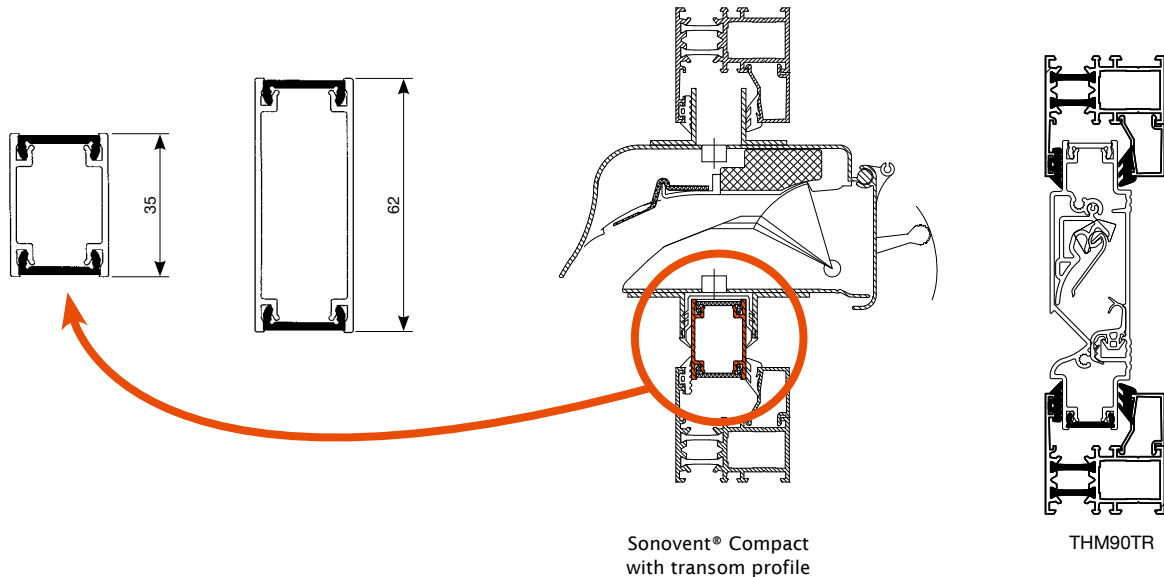

Pollux: optional fine dust and pollen filter

If you live in a strongly fine dust-loaded environment (such as near a highway or an industrial area), or if you suffer from hay fever (caused by pollen), the supply of fresh and healthy air can still be guaranteed by installing the Pollux in your RENSON window ventilator.

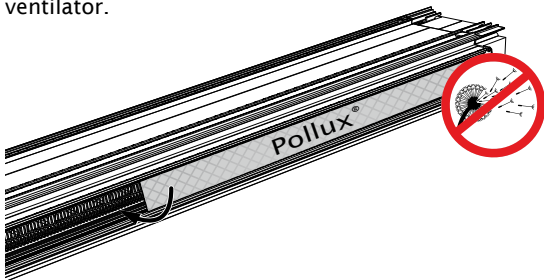

The Pollux can be installed in these RENSON window vents:

- the Invisivent^{EVO}-range
- AR60 / THK60
- AR75
- Sonovent (Compact / I / D)

Technical Specifications

Upon simple request we can present you official test reports of all our window vents.

Water- and windtightness is tested accordingly to EN 1027 and EN 1026.

The RENSON products are manufactured according to, complies with and/or has been tested according to:

EN ISO 140-10, EN ISO 717-1, EN 1026, EN 1027, EN 13141-1, EN 12020-2, EN AW 6063 T66, NBN D50-001, EN 10077-2, DIN 16491, prEN 1627, prEN 1628, prEN 1629, prEN 1630.

Patented technology

Most products in our standard range have unique features protected by patents, trademarks and worldwide intellectual property laws. Imitators and copycats will be prosecuted.

Disclaimer

Syntha Pulvin is a registered trademark of Valspar Powder Coatings Limited.

RENSON VENTILATION nv preserves the right to make technical changes without prior notice.

Technical drawings and section details are not represented at scale 1:1.

Colours, photos, technical drawings and specifications may deviate from the actual product. The latest version of this brochure can be downloaded from www.renson.eu.

Basic principles < Epilogue

How to ventilate in an energy-efficient residence?

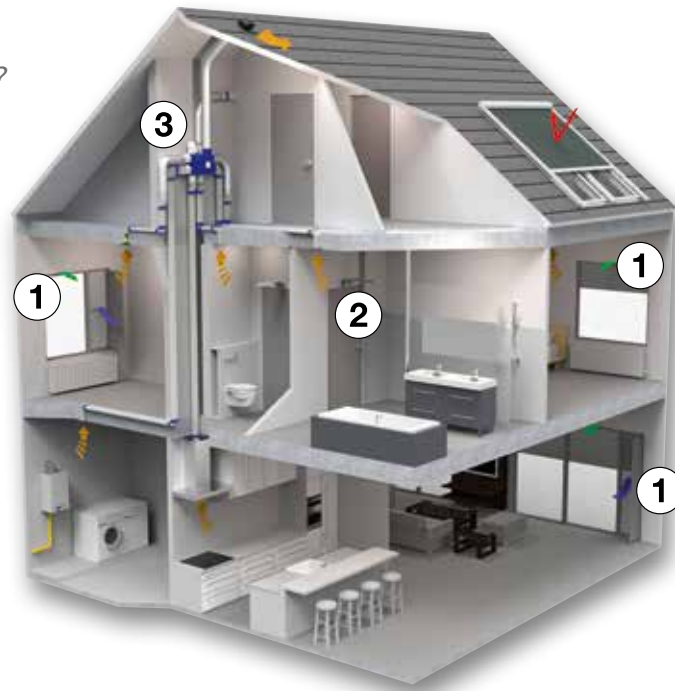

1 SELF-REGULATING SUPPLY

Self-regulating ventilators such as...



Invisivent® EVO AK Basic



AR75



Sonovent®

2 TRANSIT



Silendo®



Invisido®

3 EXTRACTION ON-DEMAND



Xtravent® Modus



Healthbox® II Compact



Healthbox® II

Energy-saving ventilation

- Constant natural supply of fresh air without draughts by means of a self-regulating flap in the ventilators.
- RENSON developed a mechanical ventilation system enabling extraction on demand of warm, polluted and humid air. This 'extraction on demand'-system is energy-saving, since its integrated software controls the ventilation flaps in an intelligent way. Specifically, the system adapts (by means of sensors) the intensity of the air extraction in function of the air humidity and the CO₂-level in the various rooms of the house.

References





Creating healthy spaces

RENSON®: your partner in ventilation and sun protection

RENSON®, headquartered in Waregem (Belgium), is a trendsetter in Europe in natural ventilation and sun protection.

- **Creating healthy spaces**

From 1909, we've been developing energy efficient solutions assuring a healthy and comfortable indoor climate.

Our remarkable headquarters - built according to the 'Healthy Building Concept' - is a beautiful example portraying our corporate mission.

- **No speed limit on innovation**

A multidisciplinary team of more than 80 R&D employees continually optimize our products and develop new and innovative concepts.

- **Strong in communication**

Contact with the customer is of the utmost importance. A group of 100 in-the-field employees worldwide and a powerful international distribution network are ready to advise you on site. EXIT 5 at Waregem gives you the possibility to experience our products on your own and provides necessary training for installers.

- **A reliable partner in business**

We can guarantee our customers optimal quality and service thanks to our environmentally friendly and modern production sites (with automated powder coating line, anodisation line, plastic injection moulding and mold making shop) covering an area of 95.000 m².

Dealer

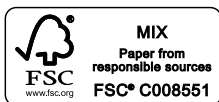

RENSON® reserves the right to make technical changes to the products shown.
The latest brochures may be downloaded from www.renson.eu

RENSON® Export Department • Tel. +32 (0)56 62 71 04 • export@renson.net

RENSON® Headquarters
IZ 2 Vijverdam • Maalbeekstraat 10 • 8790 Waregem • Belgium
Tel. +32 (0)56 62 71 11 • Fax +32 (0)56 60 28 51
info@renson.be • www.renson.eu

RENSON® Fabrications LTD
Fairfax Units 1-5 • Bircholt Road • Parkwood Industrial Estate • Maidstone • Kent ME15 9SF
Tel. 01622/754123 • Fax 01622/689478
info@rensonuk.net • www.renson.eu



Creating healthy spaces