

WINDOW VENTILATORS



OUR MISSION

Creating healthy spaces



Paul Renson

“Renson® specialises in ventilation, sun protection and outdoor. With experience dating back to 1909, and an integrated team of over 1200 employees, we develop systems and solutions which provide consumers with a healthy and comfortable

living and working environment, also taking into account energy efficiency and the use of renewable energy. We develop innovative products and systems, and offer total solutions to make every house into a healthy and comfortable home.

“We also appreciate the aesthetic values of every building, allowing our sun control and ventilation systems to be incorporated invisibly into your home. Our patio covers and aluminium blades for covering façades provide clear accents, offering added value to the architecture. Inside, we ensure that doors are integrated invisibly with no conspicuous frames or visible joints.”

Discover how Renson® products can optimise the comfort experience while guaranteeing a contemporary design.

“We develop innovative products and systems allowing for aesthetic integration in every building.”



CONTENTS

OVERVIEW	4		
INTRODUCTION			
Need for ventilation	7		
Regulations	8		
i-Flux® technology	11		
PRODUCTS			
OVERFRAME FLAP VENTILATORS			
Invisivent® AIR			
Invisivent® AIR Light	15		
Invisivent® AIR Basic	16		
Invisivent® AIR High	17		
Invisivent® COMFORT			
Invisivent® COMFORT Basic	19		
Invisivent® COMFORT High	20		
Invisivent® COMFORT Ultra	21		
Invisivent® AIR / COMFORT HR			
Invisivent® AIR HR Basic	23		
Invisivent® AIR HR High	24		
Invisivent® COMFORT HR Basic	25		
Invisivent® COMFORT HR High	26		
Invisivent® COMFORT HR Ultra	27		
Invisivent® AIR / COMFORT options	28		
FLAP VENTILATORS GLAZED-IN/AT TRANSOM			
TC45	32		
TC60	34		
AR60	36		
THK60	38		
AR75	40		
AR90	42		
		THK90	44
		THM90 ^{EVO} /THM90PB ^{EVO} /THM90TR ^{EVO}	46
		Sonovent®	48
		Sonovent® Compact	52
		ROLLER SHUTTER FLAP VENTILATOR	
		Transivent®	56
		SLIDING VENTS	
		THL100 – THL100V	60
		T100 – T130 – T150	62
		SLOTVENTS	
		Sonoslot®	68
		Sonoslot® max	70
		Pyramid	72
		PyrAcoust	74
		Interior Slotvents	76
		Exterior Slotvents	77
		COMBINED VENTILATION AND SUN SHADING	
		OVERFRAME	
		Fixvent® Mono AK ^{EVO}	80
		Fixvent® Mono UT ^{EVO}	84
		EPILOGUE	
		Additional info	88

OVERVIEW

TECHNICAL CHARACTERISTICS

	Page	Equivalent Area (mm ² /m)	Q at 1 Pa (l/s/m)	Q at 1 Pa (m ³ /h/m)	Q at 2 Pa (l/s/m)	Q at 2 Pa (m ³ /h/m)	Q at 10 Pa (l/s/m)	Q at 20 Pa (l/s/m)	Free area (mm ² /m)	Sound reduction D _{o,a} (C;C ₁) in open position (dB/m)	U-value (W/m ² K)
Overframe flap ventilators											
INVISIVENT® AIR Light	15	13479	10.6	38.1	17.2	62.0	16.4	19.2	14388.5	31 (-1;-2)	2.0
INVISIVENT® AIR Basic	16	13429	10.6	38.0	17.2	62.0	17.6	17.3	13975.5	34 (0;-1)	1.8
INVISIVENT® AIR High	17	11364	8.9	32.2	12.1	43.4	11.9	14.3	10273	40 (0;-2)	1.8
INVISIVENT® COMFORT Basic	19	4311	3.4	12.2	6.0	21.6	18.8	24.0	3900	35 (-1;-2)	1.8
INVISIVENT® COMFORT High	20	2936	2.3	8.3	4.7	16.8	12.4	18.2	3606	39 (0;-2)	1.8
INVISIVENT® COMFORT Ultra	22	2356	1.9	6.7	3.3	11.8	10.0	14.4	3606	42 (0;-2)	1.7
INVISIVENT® AIR HR Basic	23	13429	10.6	38.0	17.2	62.0	17.6	17.3	13975.5	34 (0;-1)	1.8
INVISIVENT® AIR HR High	24	11364	8.9	32.2	12.1	43.4	11.9	14.3	10273	40 (0;-2)	1.8
INVISIVENT® COMFORT HR Basic	25	4311	3.4	12.2	6.0	21.6	18.8	24.0	3900	35 (-1;-2)	1.8
INVISIVENT® COMFORT HR High	26	2936	2.3	8.3	4.7	16.8	12.4	18.2	3606	39 (0;-2)	1.8
INVISIVENT® COMFORT HR Ultra	27	2356	1.9	6.7	3.3	11.8	10.0	14.4	3606	42 (0;-2)	1.7
Flap ventilators glazed-in/at transom											
TC45	34	10435	8.2	29.5	11.5	41.4	25.8	36.5	11333	27 (0;0)	4.1
TC60	34	15652	12.3	44.3	17.4	62.6	38.9	55.0	12314	28 (0;0)	3.3
AR60	36	10427	8.2	29.5	11.8	42.3	19.7	23.9	14900	27 (0;0)	4.5
THK60	38	11841	9.3	33.5	13.2	47.5	28.6	41.8	14841	27 (0;0)	4.5
AR75 Small	40	14174	11.1	40.1	15.3	54.9	17.3	14.7	10762	26 (-1;-1)	3.0
AR75 Medium	40	17409	13.7	49.3	18.8	67.5	21.4	18.9	13531	26 (-1;-2)	3.0
AR75 Large	40	19034	15.0	53.9	22.6	81.3	24.5	21.7	16171	26 (-1;-2)	3.0
AR75 Xlarge	40	24301	19.1	68.8	29.0	104.3	31.5	28.0	18431	26 (-1;-1)	3.0
AR90	42	14252	11.2	40.3	15.6	56.2	11.4	9.1	11070	30 (-1;-2)	3.9
THK90	44	14736	11.6	41.7	16.1	57.9	34.5	48.0	14120	28 (0;-1)	3.9
THM90 ^{EVO}	46	11841	9.3	33.5	13.9	50.0	13.5	15.1	11200	26 (0;0)	3.8
THM90PB ^{EVO}	46	11841	9.3	33.5	13.9	50.0	13.5	15.1	11200	26 (0;0)	3.8
THM90TR ^{EVO}	46	11841	9.3	33.5	13.9	50.0	13.5	15.1	11200	26 (0;0)	3.8
SONOVENT® Small 10	48	17756	14.0	50.2	14.0	50.2	15.3	22.9	10000	46 (-1;-5)	4.5
SONOVENT® Small 15	48	29593	23.3	83.7	23.3	83.7	25.6	28.5	11000	41 (-1;-2)	4.5
SONOVENT® Small 20	48	31813	25.0	90.0	25.0	90.0	27.5	29.2	18900	40 (-1;-3)	4.5
SONOVENT® Small 25	48	33786	26.6	95.6	26.6	95.6	29.2	27.1	22300	37 (-1;-3)	4.5
SONOVENT® Medium 10	48	17509	13.8	49.5	13.8	49.5	15.1	-	10000	48 (-2;-6)	4.6
SONOVENT® Medium 15	48	26511	20.8	75.0	20.8	75.0	22.9	-	11000	45 (-2;-6)	4.6
SONOVENT® Medium 20	48	33292	26.2	94.2	26.2	94.2	28.8	-	18900	43 (0;-3)	4.6
SONOVENT® Medium 25	48	34032	26.7	96.3	26.7	96.3	29.4	27.5	22300	39 (-1;-4)	4.6
SONOVENT® Large 10	48	16153	12.7	45.7	12.7	45.7	14.0	-	10000	50 (-2;-6)	4.6
SONOVENT® Large 15	48	25524	20.1	72.2	20.1	72.2	22.1	-	11000	49 (-2;-7)	4.6
SONOVENT® Large 20	48	32059	25.2	90.7	25.2	90.7	27.7	-	18900	44 (-2;-6)	4.6
SONOVENT® Large 25	48	33416	26.3	94.5	26.3	94.5	28.9	25.0	22300	41 (-2;-6)	4.6
SONOVENT® XLarge 10	48	14427	11.3	40.8	11.3	40.8	12.5	-	10000	56 (-2;-6)	4.7
SONOVENT® XLarge 15	48	21578	17.0	61.0	17.0	61.0	18.7	-	11000	53 (-2;-6)	4.7
SONOVENT® XLarge 20	48	31073	24.4	87.9	24.4	87.9	26.9	-	18900	46 (-2;-6)	4.7
SONOVENT® XLarge 25	48	32676	25.7	92.4	25.7	92.4	28.2	-	22300	45 (-2;-6)	4.7
SONOVENT® Compact 10	52	15334	12.1	43.4	16.4	58.9	17.3	17.8	9500	36 (0;-1)	6.0
SONOVENT® Compact 13	52	19278	15.2	54.5	18.8	67.7	18.8	18.7	12500	35 (0;-1)	6.0
SONOVENT® Compact 15	52	24687	19.4	69.8	19.9	71.5	18.6	19.1	15000	33 (0;-1)	6.0
Roller shutter flap ventilator											
Transivent®	56	13748	10.8	38.9	15.2	54.6	20.1	19.9	16368	28 (-1;-2)	3.0
Sliding vents											
THL100	60	16759	13.2	47.4	18.7	67.2	41.6	58.9	16200	22 (0;0)	3.9
THL100V	60	12770	10.0	36.1	14.2	51.3	32.1	45.5	27950	22 (0;0)	3.9
T100	62	17326	13.6	49.0	19.5	70.3	43.8	61.9	25342	-	-
T130	62	24589	19.3	69.6	27.7	99.8	62.1	87.9	38302	-	-
T150	62	27992	22.0	79.2	31.9	114.8	71.5	101.0	45592	-	-
Slotvents											
Sonoslot®, 275 mm	68	1273	1.0	3.6	1.4	5.0	3.2	3.3	1256	38 (0;0)	1.4
Sonoslot®, 375 mm	68	1607	1.3	4.5	1.7	6.2	4.0	4.2	1885	37 (0;0)	1.4
Sonoslot®, 475 mm	68	2121	1.7	6.0	2.3	8.3	5.3	5.6	2513	36 (0;0)	1.4
Sonoslot®, 700 mm	68	3181	2.5	9.0	3.4	12.4	8.0	8.4	3769	34 (0;0)	1.4
Sonoslot® Max without damping	70	2298	1.8	6.5	2.7	9.7	6.8	6.9	1871	38 (-1;-2)	-
Sonoslot® Max with damping	70	1555	1.2	4.4	1.9	6.8	5.1	7.6	1871	40 (-1;-2)	-
Pyramid 2500	72	2723	2.1	7.6	3.1	10.85	7.0	10.1	2200	36 (0;0)	-
Pyramid 5000	72	5229	4.2	15.1	6.0	21.6	13.6	19.4	4590	33 (-1;0)	-
Pyracoust 2500 + 1 acoustic module	74	2749	2.2	7.9	3.2	11.5	7.6	11.1	2496	42 (-1;-2)	-
Pyracoust 2500 + 2 acoustic modules	74	2736	2.2	7.9	3.1	11.2	7.5	11.0	2496	45 (-2;-3)	-
Pyracoust 5000 + 1 acoustic module	74	5714	4.5	16.2	6.4	23.0	14.4	20.5	4472	39 (-1;-2)	-
Pyracoust 5000 + 2 acoustic modules	74	5596	4.3	15.5	6.2	22.3	14.5	20.8	4472	42 (-2;-4)	-
Combined ventilation and sun shading overframe											
Fixvent® Mono AK ^{EVO}	80										See technical values on page 81
Fixvent® Mono UT ^{EVO}	84										See technical values on page 85

* not for installation at transom • ** other thickness on request • *** 2000 mm glazed-in installation / 2500 mm installation at transom

Self-regulating	i-FLux®	Glass reduction (mm)	Glass thickness (mm)	Finish	Maximum length (mm)	
Overframe flap ventilators						
yes	yes	0	n.a.	anodised / RAL / dual color	6000	INVISIVENT® AIR Light
yes	yes	0	n.a.	anodised / RAL / dual color	6000	INVISIVENT® AIR Basic
yes	yes	0	n.a.	anodised / RAL / dual color	6000	INVISIVENT® AIR High
yes	yes	0	n.a.	anodised / RAL / dual color	6000	INVISIVENT® COMFORT Basic
yes	yes	0	n.a.	anodised / RAL / dual color	6000	INVISIVENT® COMFORT High
yes	yes	0	n.a.	anodised / RAL / dual color	6000	INVISIVENT® COMFORT Ultra
yes	yes	0	n.a.	anodised / RAL / dual color	6000	INVISIVENT® AIR HR Basic
yes	yes	0	n.a.	anodised / RAL / dual color	6000	INVISIVENT® AIR HR High
yes	yes	0	n.a.	anodised / RAL / dual color	6000	INVISIVENT® COMFORT HR Basic
yes	yes	0	n.a.	anodised / RAL / dual color	6000	INVISIVENT® COMFORT HR High
yes	yes	0	n.a.	anodised / RAL / dual color	6000	INVISIVENT® COMFORT HR Ultra
Flap ventilators glazed-in/at transom						
no	no	45	20/24/28	anodised / RAL / dual color	2500	TC45
no	no	60	20/24/28	anodised / RAL / dual color	2500	TC60
yes	yes	60	20/24/28	anodised / RAL / dual color	2500	AR60
no	no	60	20/24/28	anodised / RAL / dual color	2500	THK60
yes	no	75/77	20/24/28/32*/36*/40*/44*	anodised / RAL / dual color	2500	AR75 Small
yes	no	75/77	20/24/28/32*/36*/40*/44*	anodised / RAL / dual color	2500	AR75 Medium
yes	no	75/77	20/24/28/32*/36*/40*/44*	anodised / RAL / dual color	2500	AR75 Large
yes	no	75/77	20/24/28/32*/36*	anodised / RAL / dual color	2500	AR75 Xlarge
yes	no	90	20/24/28	anodised / RAL / dual color	2500 (2000 mm for motorised control)	AR90
no	no	90	20/24/28	anodised / RAL / dual color	2500 (2000 mm for motorised control)	THK90
yes	no	90	20/24/28/33	anodised / RAL / dual color	2500 (2000 mm for motorised control)	THM90 ^{EV0}
yes	no	90	20/24/28	anodised / RAL / dual color	2500 (2000 mm for motorised control)	THM90PB ^{EV0}
yes	no	90	20/24	anodised / RAL / dual color	2500 (2000 mm for motorised control)	THM90TR ^{EV0}
yes	no	130/135	20/24/28/32**	RAL / dual color	2000/2500***	SONOVENT® Small 10
yes	no	130/135	20/24/28/32**	RAL / dual color	2000/2500***	SONOVENT® Small 15
yes	no	130/135	20/24/28/32**	RAL / dual color	2000/2500***	SONOVENT® Small 20
yes	no	130/135	20/24/28/32**	RAL / dual color	2000/2500***	SONOVENT® Small 25
yes	no	130/135	20/24/28/32**	RAL / dual color	2000/2500***	SONOVENT® Medium 10
yes	no	130/135	20/24/28/32**	RAL / dual color	2000/2500***	SONOVENT® Medium 15
yes	no	130/135	20/24/28/32**	RAL / dual color	2000/2500***	SONOVENT® Medium 20
yes	no	130/135	20/24/28/32**	RAL / dual color	2000/2500***	SONOVENT® Medium 25
yes	no	130/135	20/24/28/32**	RAL / dual color	2000/2500***	SONOVENT® Large 10
yes	no	130/135	20/24/28/32**	RAL / dual color	2000/2500***	SONOVENT® Large 15
yes	no	130/135	20/24/28/32**	RAL / dual color	2000/2500***	SONOVENT® Large 20
yes	no	130/135	20/24/28/32**	RAL / dual color	2000/2500***	SONOVENT® Large 25
yes	no	130/135	20/24/28/32**	RAL / dual color	2000/2500***	SONOVENT® XLarge 10
yes	no	130/135	20/24/28/32**	RAL / dual color	2000/2500***	SONOVENT® XLarge 15
yes	no	130/135	20/24/28/32**	RAL / dual color	2000/2500***	SONOVENT® XLarge 20
yes	no	130/135	20/24/28/32**	RAL / dual color	2000/2500***	SONOVENT® XLarge 25
yes	no	78	20/24/28/32/36	RAL / dual color	2000/2500***	SONOVENT® Compact 10
yes	no	78	20/24/28/32/36	RAL / dual color	2000/2500***	SONOVENT® Compact 13
yes	no	78	20/24/28/32/36	RAL / dual color	2000/2500***	SONOVENT® Compact 15
Roller shutter flap ventilator						
yes	yes	n.a.	n.a.	anodised / RAL	2200 (1500 mm for cord control)	Transivent®
Sliding vents						
no	no	129	15*/20/24/28	anodised / RAL / dual color	3500	THL100
no	no	129	15*/20/24/28	anodised / RAL / dual color	3500	THL100V
no	no	n.a.	n.a.	anodised / RAL / dual color	3500	T100
no	no	n.a.	n.a.	anodised / RAL / dual color	3500	T130
no	no	n.a.	n.a.	anodised / RAL / dual color	3500	T150
Slotvents						
yes	yes	n.a.	n.a.	anodised / Renson standard WHITE, 9005, 1247	275	Sonoslot®, 275 mm
yes	yes	n.a.	n.a.	anodised / Renson standard WHITE, 9005, 1247	375	Sonoslot®, 375 mm
yes	yes	n.a.	n.a.	anodised / Renson standard WHITE, 9005, 1247	475	Sonoslot®, 475 mm
yes	yes	n.a.	n.a.	anodised / Renson standard WHITE, 9005, 1247	700	Sonoslot®, 700 mm
yes	no	n.a.	n.a.	Renson standard WHITE / RAL 1247	700	Sonoslot® Max without damping
yes	no	n.a.	n.a.	Renson standard WHITE / RAL 1247	700	Sonoslot® Max with damping
no	no	n.a.	n.a.	anodised / Renson standard WHITE, 9005, 7016	n.a.	Pyramid 2500
no	no	n.a.	n.a.	anodised / Renson standard WHITE, 9005, 7016	n.a.	Pyramid 5000
no	no	n.a.	n.a.	anodised / Renson standard WHITE, 9005, 7016	n.a.	Pyracoust 2500 + 1 acoustic module
no	no	n.a.	n.a.	anodised / Renson standard WHITE, 9005, 7016	n.a.	Pyracoust 2500 + 2 acoustic modules
no	no	n.a.	n.a.	anodised / Renson standard WHITE, 9005, 7016	n.a.	Pyracoust 5000 + 1 acoustic module
no	no	n.a.	n.a.	anodised / Renson standard WHITE, 9005, 7016	n.a.	Pyracoust 5000 + 2 acoustic modules
Combined ventilation and sun shading overframe						
						Fixvent® Mono AK ^{EV0}
						Fixvent® Mono UT ^{EV0}

See technical values on page 81
See technical values on page 85

n.a. : not applicable • airflow based upon aluminiumsize = 1000 mm (except slotvents)



NEED FOR VENTILATION?

Every day, the indoor air is being polluted by its inhabitants (breathing, sweating), through their activities (cooking, showering, heating and smoking), but also by the building itself and its furnishing (radon, volatile organic compounds, paint, detergents,...). Excessive insulation and inadequate ventilation create a dead and stale air which accumulates mites, molds, viruses, bacteria, as well as moisture and harmful chemicals such as CO₂.

VENTILATION: FOR YOU AND YOUR HOME!

Many people think that opening the window from time to time is sufficient. However, the effect of opening a window is only temporary and ventilation through open windows is uncontrollable (and therefore wasted energy).

In addition, opening the window leads to other problems such as noise, the risk of burglary, the intrusion of insects and so on.

Continuous and controlled ventilation is the only effective method to ensure a healthy indoor climate.

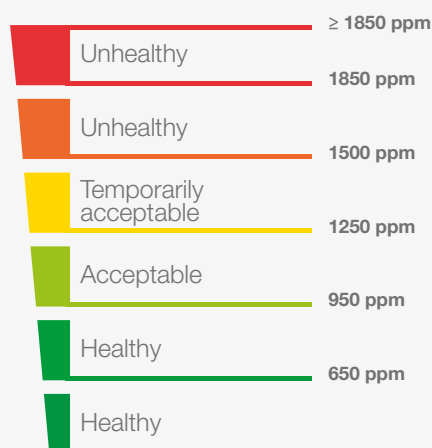

A poor indoor climate may cause breathing problems, dry throat, eye irritation, headaches, allergies, impaired concentration, lack of energy, sleepiness, Moreover, excess moisture in the home can cause odors, condensation and mold growth, hence the importance to properly ventilate on a regular basis.

CO₂ MONITOR

The CO₂ concentration is an important indicator for good indoor air quality and can be measured with the Renson® CO₂-monitor. The air quality becomes expressed in CO₂ particles per million air particles. [ppm = parts per million].

The maximum assumed value is 1200 ppm CO₂. Above this value, people may suffer headache, drowsiness, fatigue or irritation of the mucous membranes at a CO₂ concentrations above 1000 ppm the concentration ability decreases.



REGULATIONS

Brief guide to UK building regulations, part F - ventilation

DOMESTIC BUILDINGS

New Buildings (with any design air permeability)

Previously ventilation area was shown in free area mm² whereas now it is calculated and shown as Equivalent Area (EA) per mm² as in the table shown below based upon 2 occupants in the main bedroom and a single occupant in all other bedrooms.

Total floor area [m ²]	Number of bedrooms				
	1	2	3	4	5
< 50	35000	40000	50000	60000	65000
51 - 60	35000	40000	50000	60000	65000
61 - 70	45000	45000	50000	60000	65000
71 - 80	50000	50000	50000	60000	65000
81 - 90	55000	60000	60000	60000	65000
91 - 100	65000	65000	65000	65000	65000
> 100	add 7000 mm ² for every additional 10 m ² floor area				

The minimum equivalent area (EA) for habitable rooms is 5000 mm² EA and for any wet room 2500 mm² EA.

Please contact Renson® UK for more information regarding basements, habitable rooms with non opening windows, modular or portable buildings and acoustic needs for buildings.

Existing Buildings

Where renovations are being carried out to an existing building then the background ventilation should not be smaller than originally provided, but it must be at least 5000 mm² EA for habitable rooms and 2500 mm² EA for wet rooms.

Please contact Renson® UK for more information regarding connecting to a conservatory, addition of a wet room or addition of a habitable room.

NON-DOMESTIC BUILDINGS

New Offices

10 l/s (litres per second) per person of air supply is needed

Existing offices, hotels, ...

- Floor area under 10 m² - 2500 mm² EA
- Floor area over 10 m² - 250 mm²/m² EA
- Kitchens - 2500 mm² EA
- Bathrooms/showers/WC - 2500 mm² EA per bath, shower or toilet

New schools [according to Building Bulletin 101]

8 l/s (litres per second) per person of air supply is needed.





PRINCIPLES



Due to the application of the i-Flux technology, Renson® can guarantee maximum comfort with minimum energy loss with the window vents. i-Flux technology is based on the following three principles:

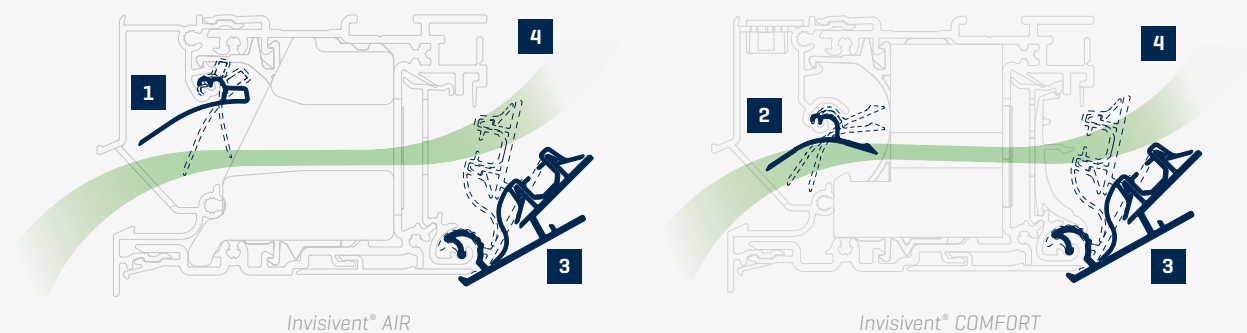

1. AIRFLOW INDEPENDENT OF THE WIND

The use of a self-regulating valve that reacts to changes in pressure makes it possible to maintain a constant airflow even in case of wind gusts, and keeps out draughts. Self-regulation is expressed in different classes, from class P0 [not self-regulating] to P4 [excellent self-regulating].

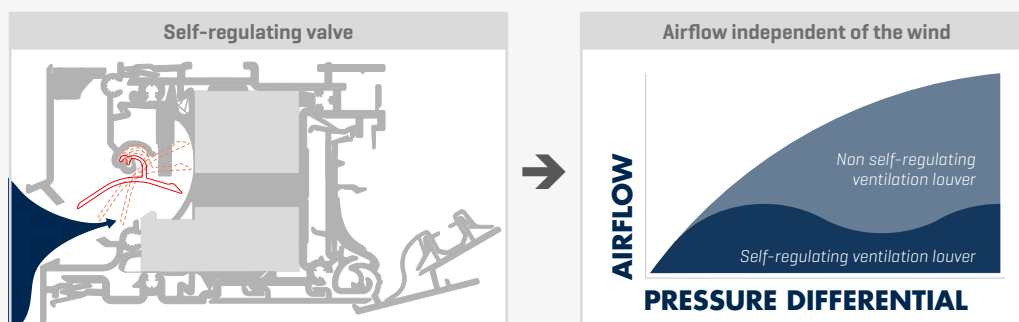

2. MINIMAL ENERGY LOSS DUE TO THE NON-RETURN VALVE

Because the valve of the Invisivent Comfort is a self-regulating non-return valve, any energy loss from the inside out is avoided.

3. AIRFLOW DETERMINED WITH MANUALLY ADJUSTABLE INNER VALVE

The user can determine the desired airflow, e.g. according to the number of people in the room.

4. UPWARD AIRFLOW FOR OPTIMUM COMFORT

The shape of the inner valve conducts the fresh air upwards, leading to optimal air distribution throughout the room and guaranteeing maximum comfort.

OVERFRAME FLAP VENTILATORS



Invisivent® COMFORT



Invisivent® COMFORT



Invisivent® COMFORT

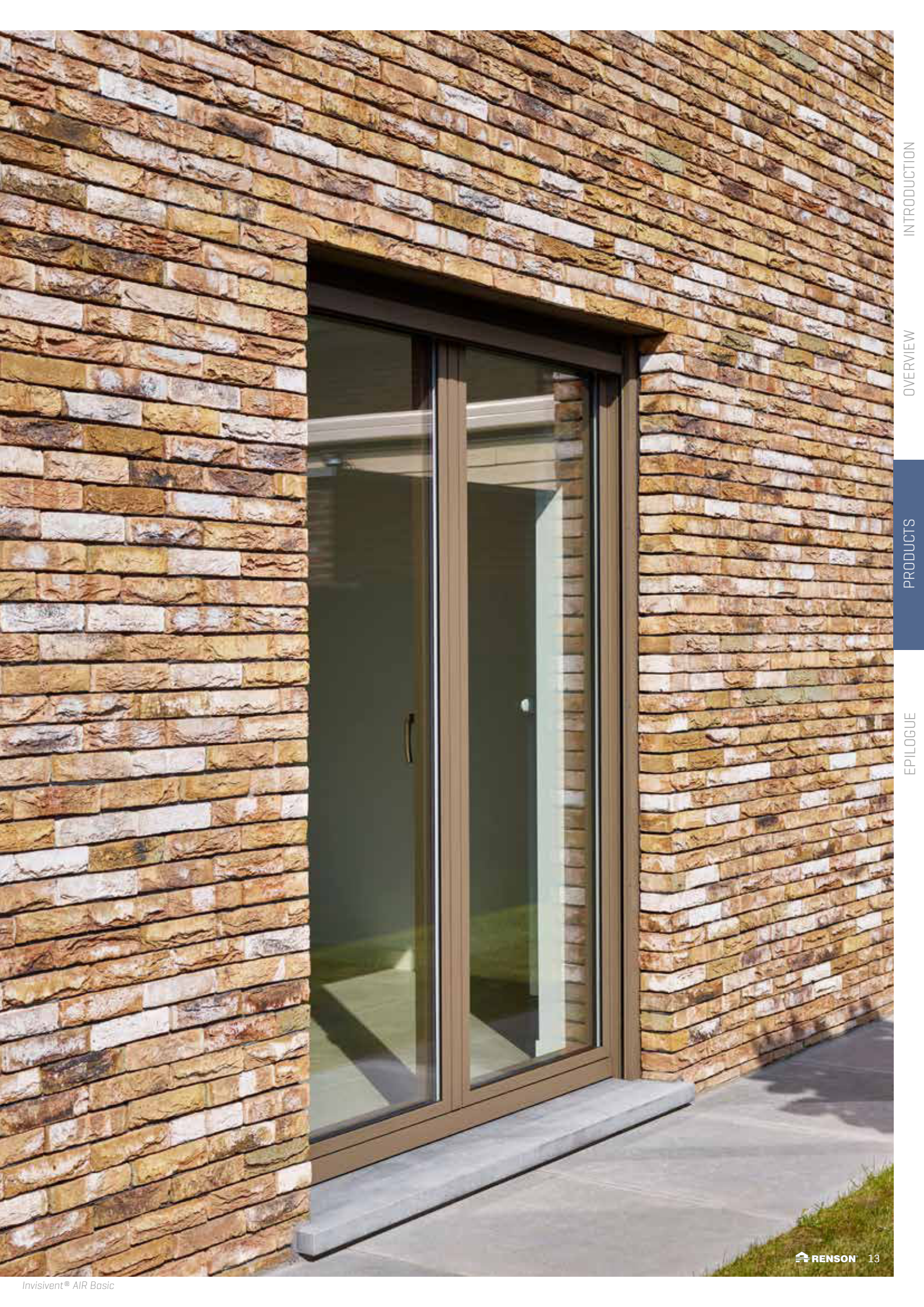

INVISIVENT® AIR LIGHT

TECHNICAL CHARACTERISTICS

Airflow	
Equivalent area	13479 mm ² /m
Q at 1 Pa	10.6 l/s/m
Q at 1 Pa	38.1 m ³ /h/m
Q at 2 Pa	17.2 l/s/m
Q at 2 Pa	62.0 m ³ /h/m
Q at 10 Pa	16.4 l/s/m
Q at 20 Pa	19.2 l/s/m
Comfort	
Sound reduction $D_{n,e,w}$ [C;C _{tr}]	
In open position	31 [-1;-2] dB
In closed position	51 [-1;-3] dB
Technical characteristics	
Controllable internal flap	5 positions
Control options internal flap	Manual, cord, rod
U value	2,0 W/m ² K
Air leakage at 50 Pa	<15% [in closed position]
Watertightness in closed position, up to	900 Pa
Watertightness in open position, up to	150 Pa - 250 Pa [with design exterior cover]
Dimensions	
Glass reduction	0 mm
Height	65 mm
Depths window frame	50 - 202 mm [or more upon request]
Max. length	6000 mm



TECHNICAL DRAWINGS

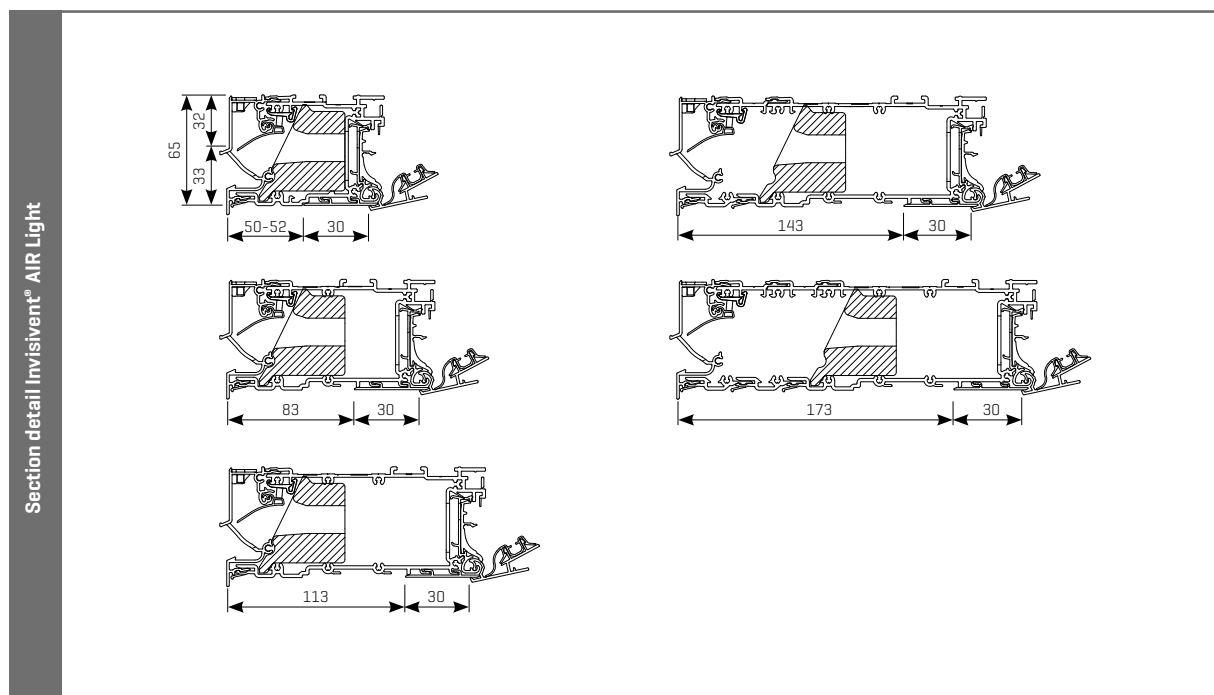

INVISIVENT® AIR BASIC



TECHNICAL CHARACTERISTICS

Airflow	
Equivalent area	13429 mm ² /m
Q at 1 Pa	10.6 l/s/m
Q at 1 Pa	38.0 m ³ /h/m
Q at 2 Pa	17.2 l/s/m
Q at 2 Pa	62.0 m ³ /h/m
Q at 10 Pa	17.6 l/s/m
Q at 20 Pa	17.3 l/s/m
Comfort	
Sound reduction $D_{n,e,w}$ [C;C _{tr}]	
In open position	34 [0;-1] dB
In closed position	51 [-1;-3] dB
Technical characteristics	
Controllable internal flap	5 positions
Control options internal flap	Manual, cord, rod
U value	1,8 W/m ² K
Air leakage at 50 Pa	<15% [in closed position]
Watertightness in closed position, up to	900 Pa
Watertightness in open position, up to	150 Pa - 250 Pa [with design exterior cover]
Dimensions	
Glass reduction	0 mm
Height	65 mm
Depths window frame	50 - 202 mm [or more upon request]
Max. length	6000 mm

TECHNICAL DRAWINGS

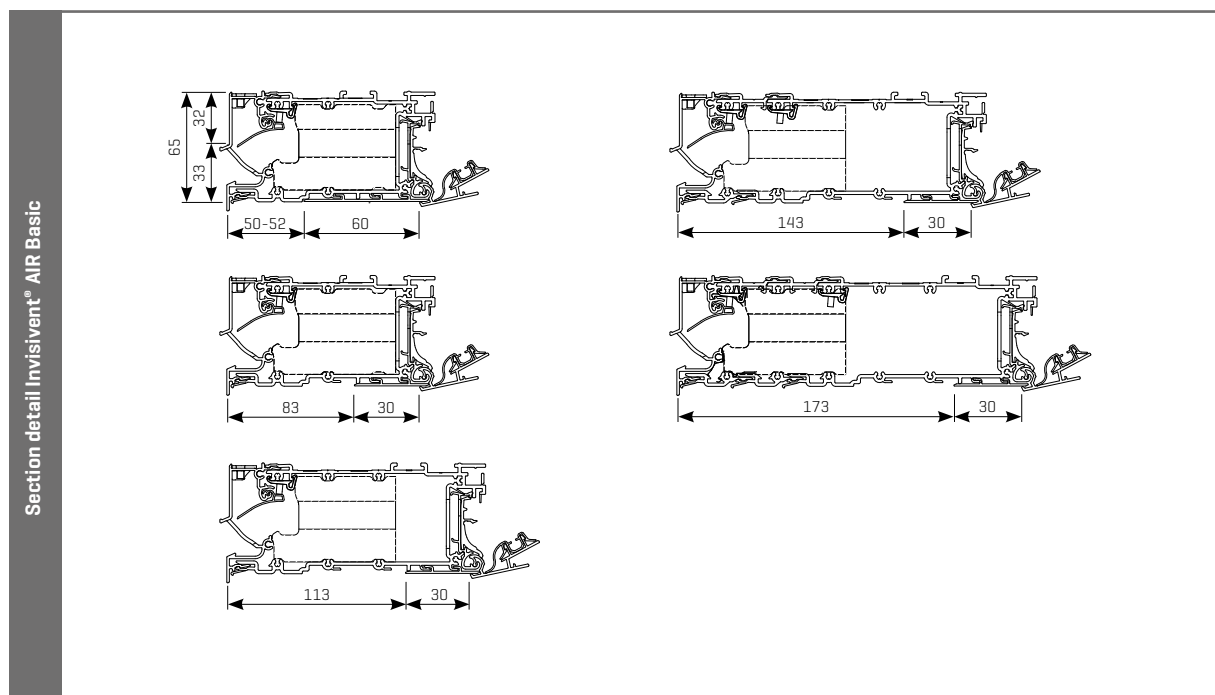

INVISIVENT® AIR HIGH

TECHNICAL CHARACTERISTICS

Airflow	
Equivalent area	11364 mm ² /m
Q at 1 Pa	8.9 l/s/m
Q at 1 Pa	32.2 m ³ /h/m
Q at 2 Pa	12.1 l/s/m
Q at 2 Pa	43.4 m ³ /h/m
Q at 10 Pa	11.9 l/s/m
Q at 20 Pa	14.3 l/s/m
Comfort	
Sound reduction $D_{n,e,w}$ [C;C _{tr}]	
In open position	40 [0;-2] dB
In closed position	51 [-1;-3] dB
Technical characteristics	
Controllable internal flap	5 positions
Control options internal flap	Manual, cord, rod
U value	1,8 W/m ² K
Air leakage at 50 Pa	<15% [in closed position]
Watertightness in closed position, up to	900 Pa
Watertightness in open position, up to	150 Pa - 250 Pa [with design exterior cover]
Dimensions	
Glass reduction	0 mm
Height	65 mm
Depths window frame	50 - 202 mm [or more upon request]
Max. length	6000 mm



TECHNICAL DRAWINGS

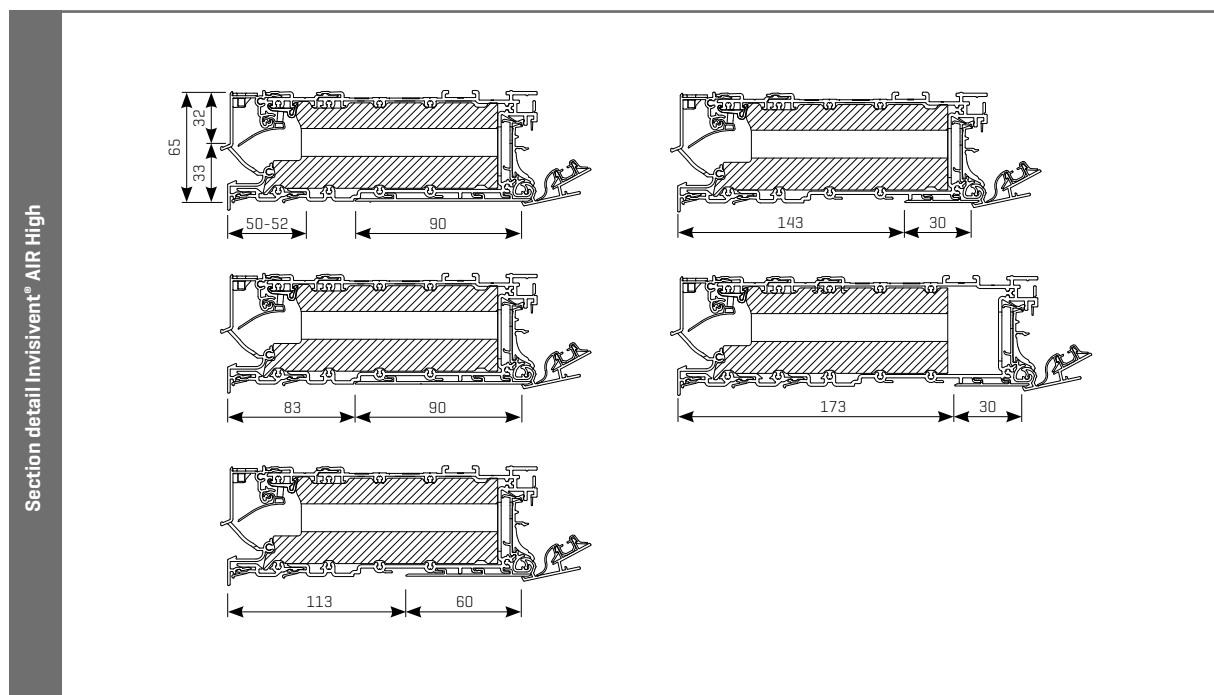

INVISIVENT® COMFORT BASIC

TECHNICAL CHARACTERISTICS

Airflow	
Equivalent area	4311 mm ² /m
Q at 1 Pa	3.4 l/s/m
Q at 1 Pa	12.2 m ³ /h/m
Q at 2 Pa	6.0 l/s/m
Q at 2 Pa	21.6 m ³ /h/m
Q at 10 Pa	18.8 l/s/m
Q at 20 Pa	24.0 l/s/m
Comfort	
Sound reduction $D_{n,e,w}$ [C;C _{tr}]	
In open position	35 [-1;-2] dB
In closed position	51 [-1;-3] dB
Technical characteristics	
Controllable internal flap	5 positions
Control options internal flap	Manual, cord, rod
U value	1,8 W/m ² K
Air leakage at 50 Pa	<15% [in closed position]
Watertightness in closed position, up to	900 Pa
Watertightness in open position, up to	150 Pa - 250 Pa [with design exterior cover]
Dimensions	
Glass reduction	0 mm
Height	65 mm
Depths window frame	50 - 202 mm [or more upon request]
Max. length	6000 mm



TECHNICAL DRAWINGS

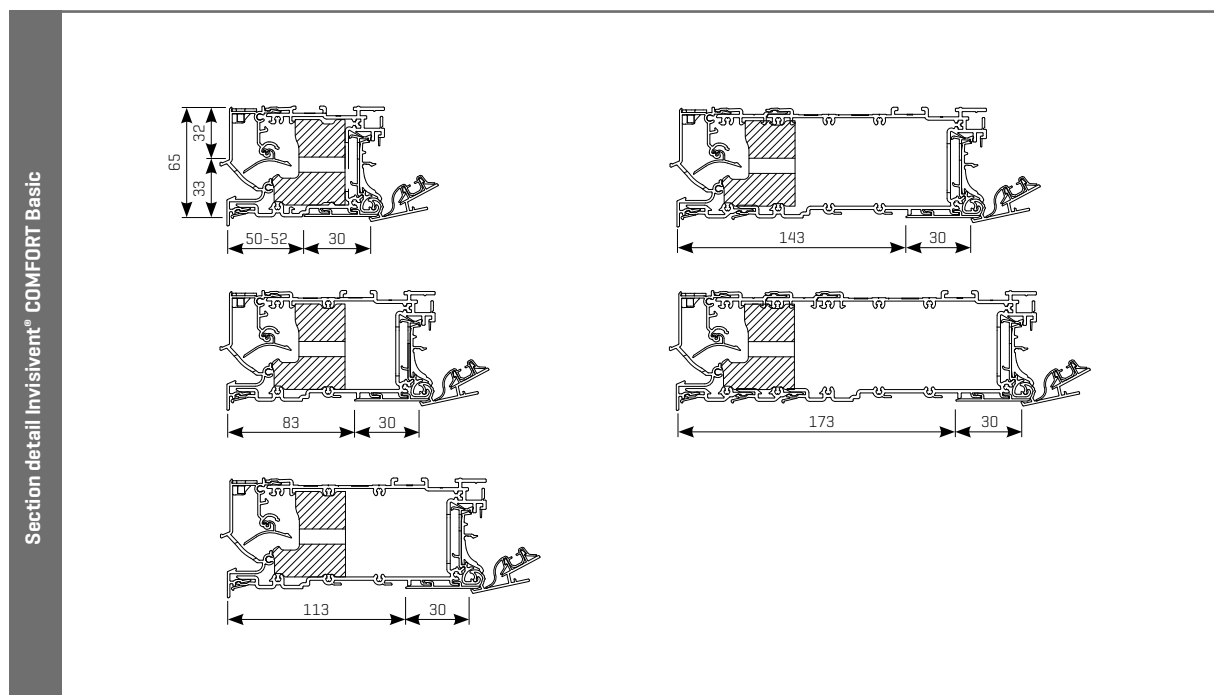

INVISIVENT® COMFORT HIGH



TECHNICAL CHARACTERISTICS

Airflow	
Equivalent area	2936 mm ² /m
Q at 1 Pa	2.3 l/s/m
Q at 1 Pa	8.3 m ³ /h/m
Q at 2 Pa	4.7 l/s/m
Q at 2 Pa	16.8 m ³ /h/m
Q at 10 Pa	12.4 l/s/m
Q at 20 Pa	18.2 l/s/m
Comfort	
Sound reduction $D_{n,e,w}$ [C;C _{tr}]	
In open position	39 [0;-2] dB
In closed position	51 [-1;-3] dB
Technical characteristics	
Controllable internal flap	5 positions
Control options internal flap	Manual, cord, rod
U value	1,8 W/m ² K
Air leakage at 50 Pa	<15% [in closed position]
Watertightness in closed position, up to	900 Pa
Watertightness in open position, up to	150 Pa - 250 Pa [with design exterior cover]
Dimensions	
Glass reduction	0 mm
Height	65 mm
Depths window frame	50 - 202 mm [or more upon request]
Max. length	6000 mm

TECHNICAL DRAWINGS

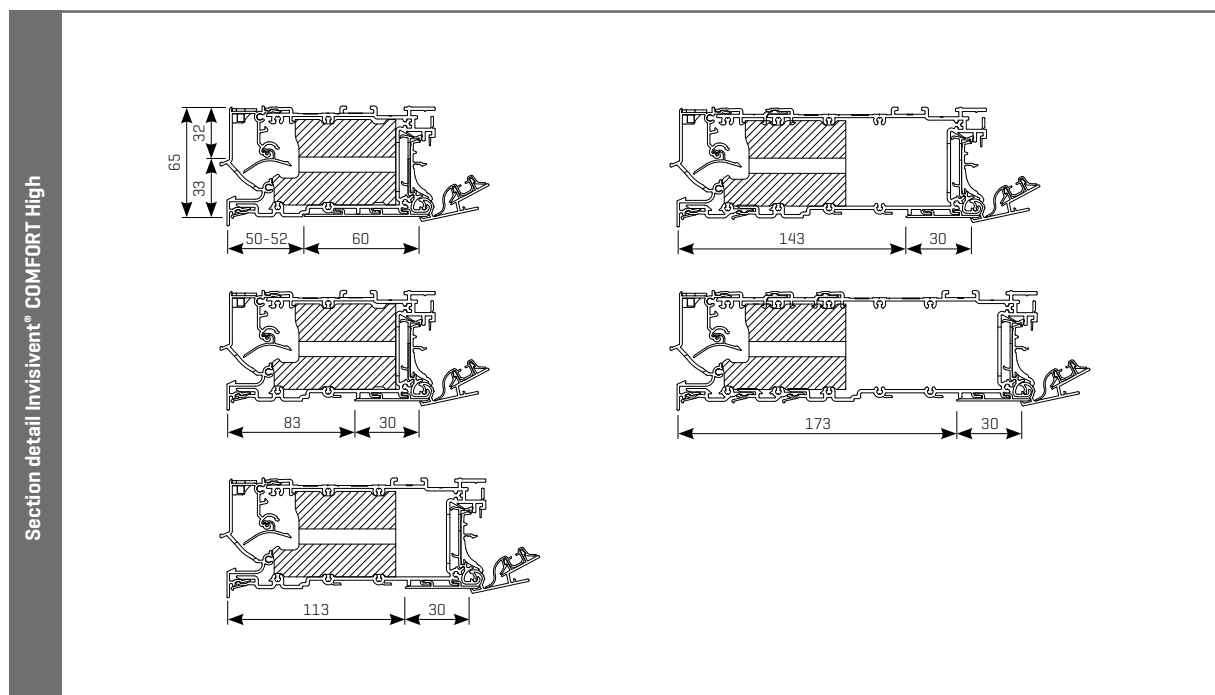

INVISIVENT® COMFORT ULTRA

TECHNICAL CHARACTERISTICS

Airflow	
Equivalent area	2356 mm ² /m
Q at 1 Pa	1.9 l/s/m
Q at 1 Pa	6.7 m ³ /h/m
Q at 2 Pa	3.3 l/s/m
Q at 2 Pa	11.8 m ³ /h/m
Q at 10 Pa	10.0 l/s/m
Q at 20 Pa	14.4 l/s/m
Comfort	
Sound reduction $D_{n,e,w}$ [C;C _{tr}]	
In open position	42 [0;-2] dB
In closed position	51 [-1;-3] dB
Technical characteristics	
Controllable internal flap	5 positions
Control options internal flap	Manual, cord, rod
U value	1,7 W/m ² K
Air leakage at 50 Pa	<15% [in closed position]
Watertightness in closed position, up to	900 Pa
Watertightness in open position, up to	150 Pa - 250 Pa [with design exterior cover]
Dimensions	
Glass reduction	0 mm
Height	65 mm
Depths window frame	50 - 202 mm [or more upon request]
Max. length	6000 mm



TECHNICAL DRAWINGS

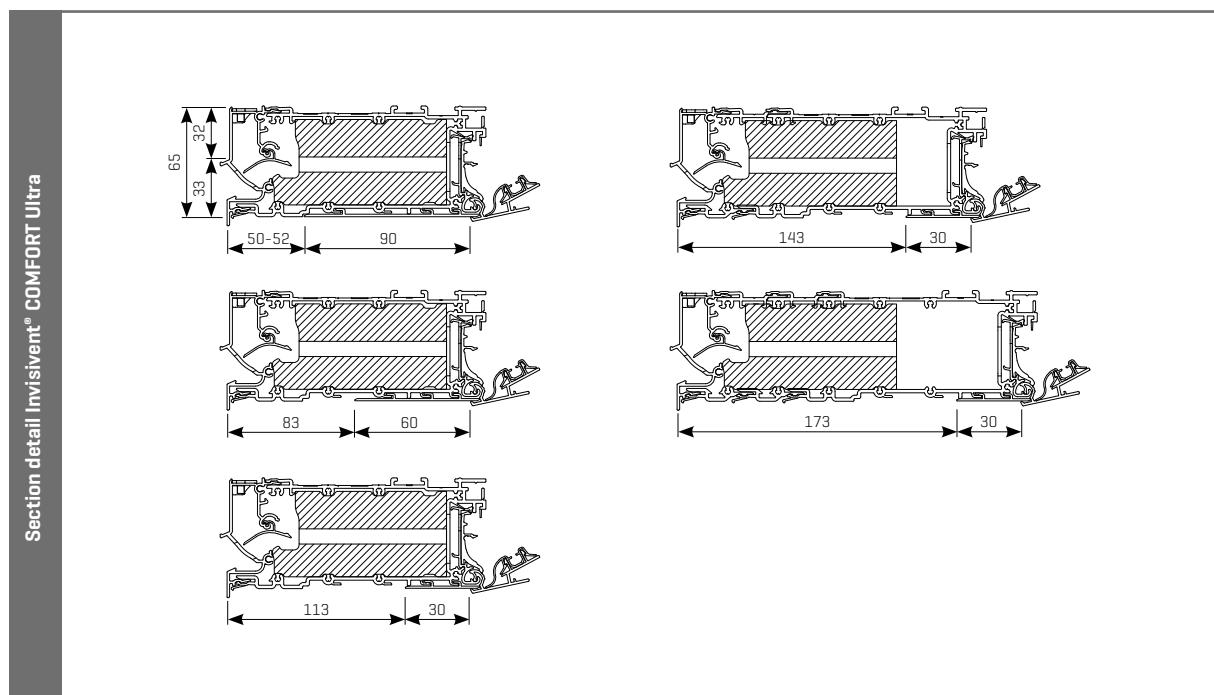

INVISIVENT® AIR / COMFORT HR

Self-regulating, discreet and acoustic window ventilation for high wind loads

ON WINDOW
PROFILE



Invisivent AIR HR Basic

SELF-REGULATING
WITH NON-
RETURN VALVE

ACOUSTIC
DAMPING

APPLICATIONS
THAT ARE
SUSCEPTIBLE
TO WIND

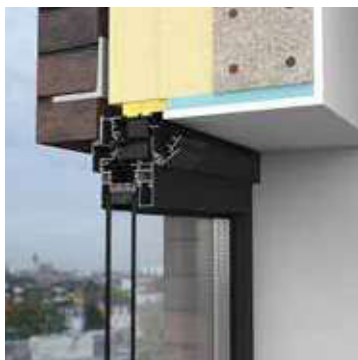

Invisivent COMFORT HR Basic

INTRO

The new Invisivent AIR and COMFORT window ventilation systems are also available in a 'High Rise' model. These window vents are the ideal solution for applications that are susceptible to wind, such as high-rise buildings and blocks of flats near the coast.

The Invisivent AIR HR and COMFORT HR come equipped as standard with a design exterior cover, which ensures optimal water resistance in even the most extreme weather conditions.

Moreover, additional clips guarantee that the inner valve operates with the perfect closing force. Each High Rise model contains acoustic material that dampens external noises to the greatest extent possible, resulting in increased user comfort. The HR model is available in 5 different sound-damping levels [Invisivent AIR Basic/High and Invisivent COMFORT Basic/High/Ultra].

INSTALLATION ON TOP OF THE WINDOW PROFILE

The Invisivent AIR HR/COMFORT HR can be placed behind the wall on top of aluminium, wood, or PVC window profiles. As the glass size remains the same, this almost perfectly concealed installation method guarantees maximum daylight.

PERFECT AIRTIGHT CONNECTION ON WINDOW PROFILE

A coextruded flexible rubber seal that runs across the entire length of the window ventilation [including the end caps] guarantees a perfectly airtight connection between the Invisivent and the window profile.

I-FLUX® WITH NON-RETURN VALVE

Thanks to its self-regulating valve, the Invisivent AIR HR/COMFORT HR ensures that fresh and healthy air is supplied without any draught. Because the self-regulating valve in the Invisivent COMFORT HR comes with a non-return function, any energy loss from the interior towards the outside is prevented.

Moreover, the manually adjustable inner valve pushes the incoming airflow upwards, ensuring optimal distribution of fresh air in your home.

SUPERIOR ACOUSTIC COMFORT

Even in their narrowest versions, Invisivent AIR/COMFORT HR window ventilation systems are fitted with acoustic damping material as standard. An acoustic leak to the cavity offers extra-impressive acoustic performance.

In open position: Invisivent AIR HR Basic: 34 [0;-1] dB
Invisivent AIR HR High: 40 [0;-2] dB
Invisivent COMFORT HR Basic: 35 [-1;-2] dB
Invisivent COMFORT HR High: 39 [0;-2] dB
Invisivent COMFORT HR Ultra: 42 [0;-2] dB

INSECT-PROOF

The perforated inner profile keeps out mosquitoes, flies, and other unwelcome insects.

BURGLAR PROOF

The Invisivent AIR/COMFORT HR range complies with the Class 2 burglar resistance standard, which makes it suitable for a Class WK2 window.

INVISIVENT® AIR HR BASIC

TECHNICAL CHARACTERISTICS

Airflow	
Equivalent area	13429 mm ² /m
Q at 1 Pa	10.6 l/s/m
Q at 1 Pa	38.0 m ³ /h/m
Q at 2 Pa	17.2 l/s/m
Q at 2 Pa	62.0 m ³ /h/m
Q at 10 Pa	17.6 l/s/m
Q at 20 Pa	17.3 l/s/m
Comfort	
Sound reduction $D_{n,e,w}$ [C;C _{tr}]	
In open position	34 [0;-1] dB
In closed position	51 [-1;-3] dB
Technical characteristics	
Controllable internal flap	16 positions
Control options internal flap	Manual, cord, rod
U value	1,8 W/m ² K
Air leakage at 50 Pa	<15% [in closed position]
Watertightness in closed position, up to	1200 Pa
Watertightness in open position, up to	250 Pa
Dimensions	
Glass reduction	0 mm
Height	66,5 mm
Depths window frame	50 - 202 mm [or more upon request]
Max. length	6000 mm



TECHNICAL DRAWINGS

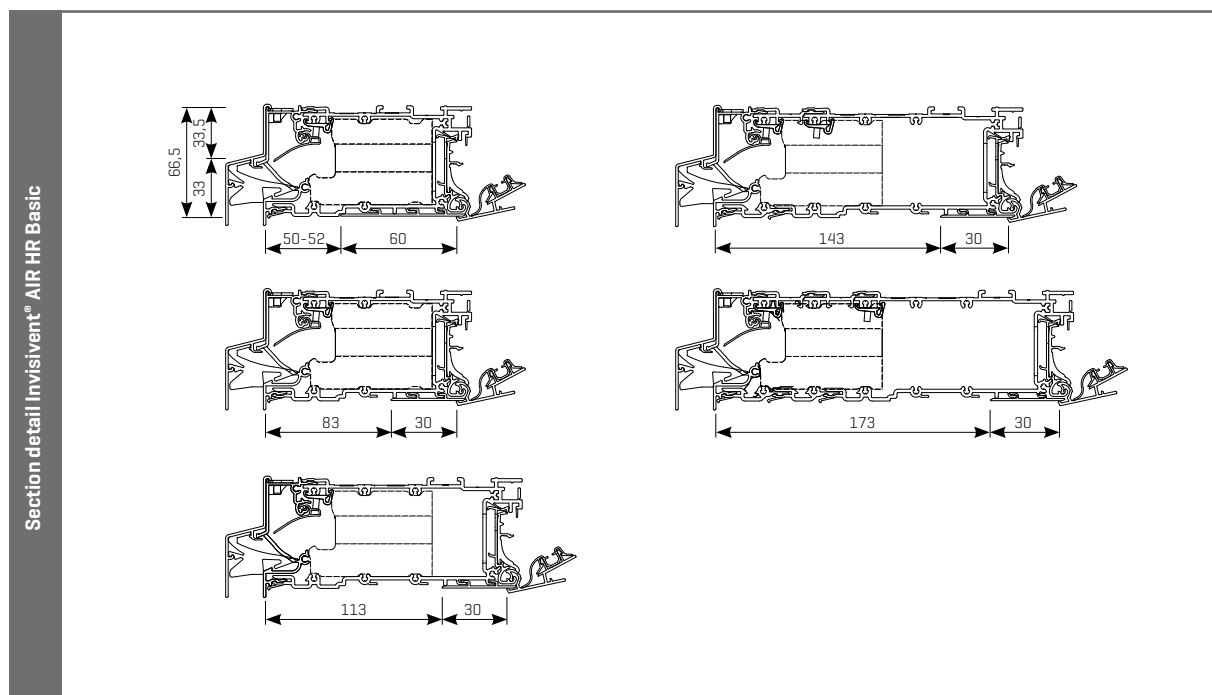

INVISIVENT® AIR HR HIGH



TECHNICAL CHARACTERISTICS

Airflow	
Equivalent area	11364 mm ² /m
Q at 1 Pa	8.9 l/s/m
Q at 1 Pa	32.2 m ³ /h/m
Q at 2 Pa	12.1 l/s/m
Q at 2 Pa	43.4 m ³ /h/m
Q at 10 Pa	11.9 l/s/m
Q at 20 Pa	14.3 l/s/m
Comfort	
Sound reduction D _{n,e,w} [C;C _{tr}]	
In open position	40 [0;-2] dB
In closed position	51 [-1;-3] dB
Technical characteristics	
Controllable internal flap	16 positions
Control options internal flap	Manual, cord, rod
U value	1,8 W/m ² K
Air leakage at 50 Pa	<15% [in closed position]
Watertightness in closed position, up to	1200 Pa
Watertightness in open position, up to	250 Pa
Dimensions	
Glass reduction	0 mm
Height	66,5 mm
Depths window frame	50 - 202 mm [or more upon request]
Max. length	6000 mm

TECHNICAL DRAWINGS

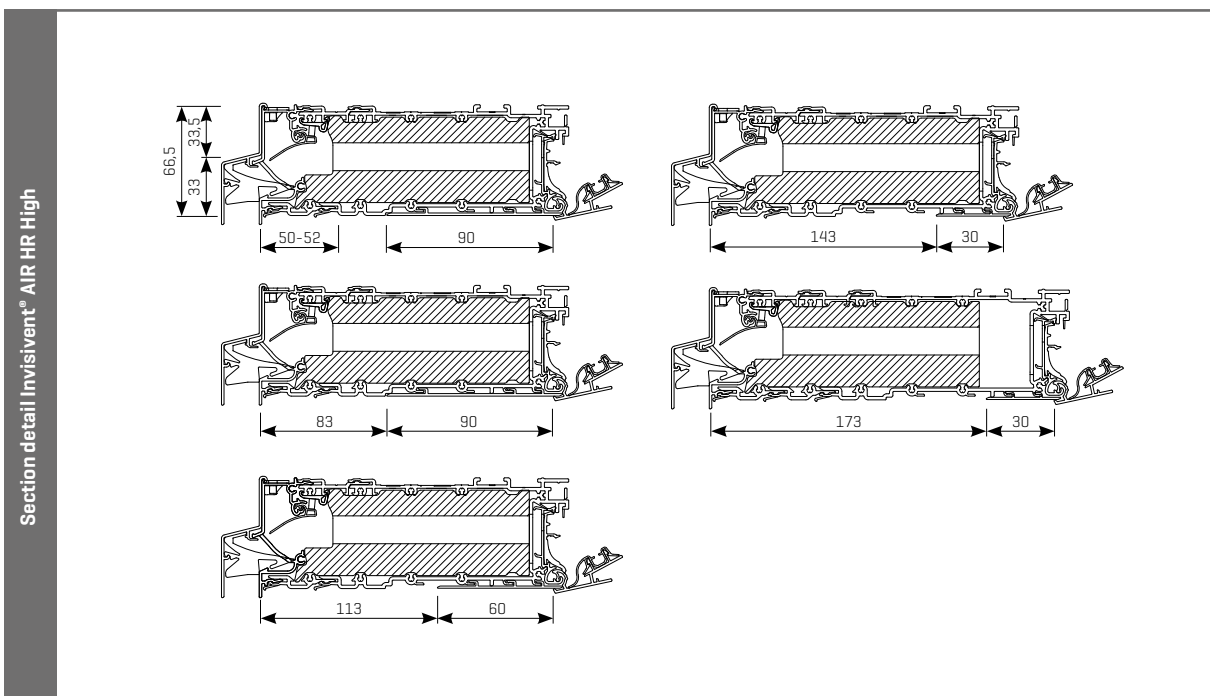

INVISIVENT® COMFORT HR BASIC

TECHNICAL CHARACTERISTICS

Airflow	
Equivalent area	4311 mm ² /m
Q at 1 Pa	3.4 l/s/m
Q at 1 Pa	12.2 m ³ /h/m
Q at 2 Pa	6.0 l/s/m
Q at 2 Pa	21.6 m ³ /h/m
Q at 10 Pa	18.8 l/s/m
Q at 20 Pa	24.0 l/s/m
Comfort	
Sound reduction $D_{n,e,w}$ [C;C _{tr}]	
In open position	35 [-1;-2] dB
In closed position	51 [-1;-3] dB
Technical characteristics	
Controllable internal flap	16 positions
Control options internal flap	Manual, cord, rod
U value	1,8 W/m ² K
Air leakage at 50 Pa	<15% [in closed position]
Watertightness in closed position, up to	1200 Pa
Watertightness in open position, up to	250 Pa
Dimensions	
Glass reduction	0 mm
Height	66,5 mm
Depths window frame	50 - 202 mm (or more upon request)
Max. length	6000 mm



TECHNICAL DRAWINGS

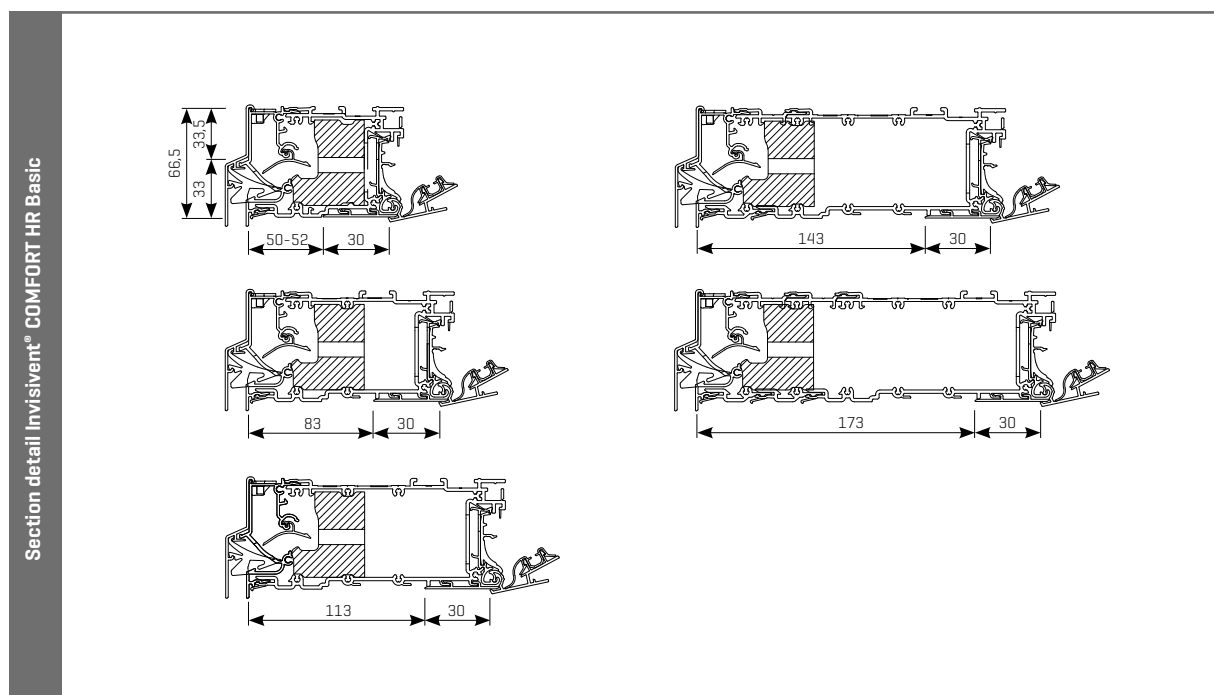

INVISIVENT® COMFORT HR HIGH



TECHNICAL CHARACTERISTICS

Airflow	
Equivalent area	2936 mm ² /m
Q at 1 Pa	2.3 l/s/m
Q at 1 Pa	8.3 m ³ /h/m
Q at 2 Pa	4.7 l/s/m
Q at 2 Pa	16.8 m ³ /h/m
Q at 10 Pa	12.4 l/s/m
Q at 20 Pa	18.2 l/s/m
Comfort	
Sound reduction $D_{n,e,w}$ [C;C _{tr}]	
In open position	39 [0;-2] dB
In closed position	51 [-1;-3] dB
Technical characteristics	
Controllable internal flap	16 positions
Control options internal flap	Manual, cord, rod
U value	1,8 W/m ² K
Air leakage at 50 Pa	<15% [in closed position]
Watertightness in closed position, up to	1200 Pa
Watertightness in open position, up to	250 Pa
Dimensions	
Glass reduction	0 mm
Height	66,5 mm
Depths window frame	50 - 202 mm [or more upon request]
Max. length	6000 mm

TECHNICAL DRAWINGS

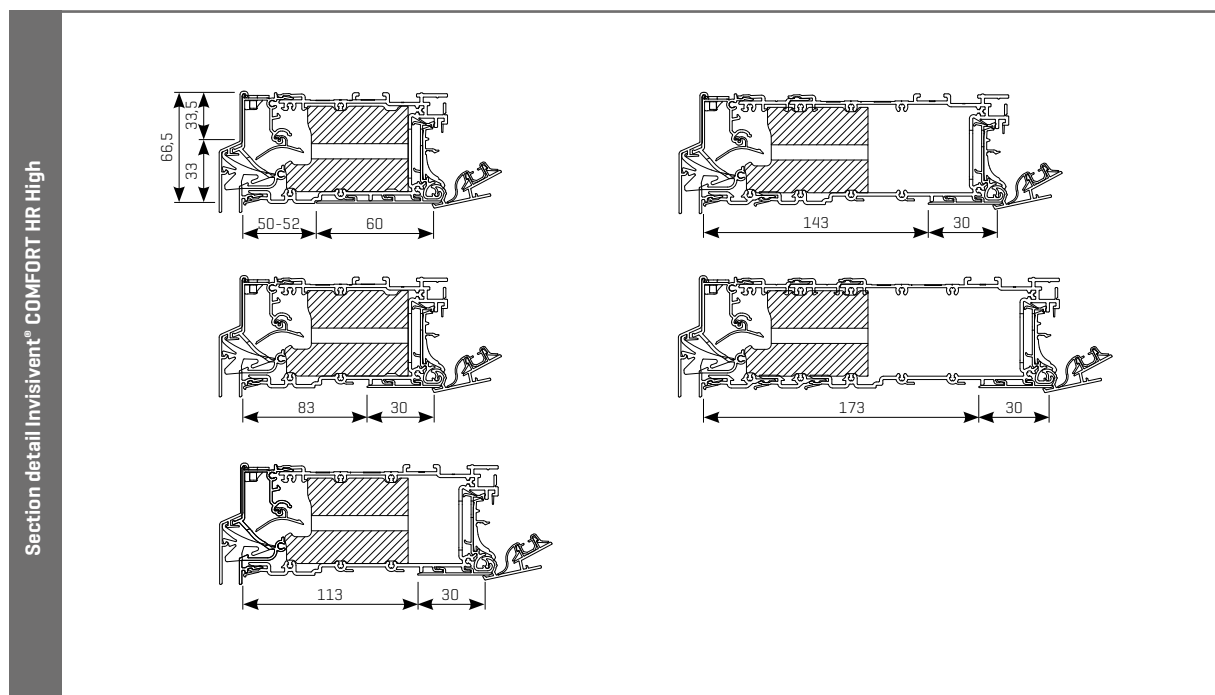

INVISIVENT® COMFORT HR ULTRA

TECHNICAL CHARACTERISTICS

Airflow	
Equivalent area	2356 mm ² /m
Q at 1 Pa	1.9 l/s/m
Q at 1 Pa	6.7 m ³ /h/m
Q at 2 Pa	3.3 l/s/m
Q at 2 Pa	11.8 m ³ /h/m
Q at 10 Pa	10.0 l/s/m
Q at 20 Pa	14.4 l/s/m
Comfort	
Sound reduction $D_{n,e,w}$ [C;C _{tr}]	
In open position	42 [0;-2] dB
In closed position	51 [-1;-3] dB
Technical characteristics	
Controllable internal flap	16 positions
Control options internal flap	Manual, cord, rod
U value	1,7 W/m ² K
Air leakage at 50 Pa	<15% [in closed position]
Watertightness in closed position, up to	1200 Pa
Watertightness in open position, up to	250 Pa
Dimensions	
Glass reduction	0 mm
Height	66,5 mm
Depths window frame	50 - 202 mm (or more upon request)
Max. length	6000 mm



TECHNICAL DRAWINGS

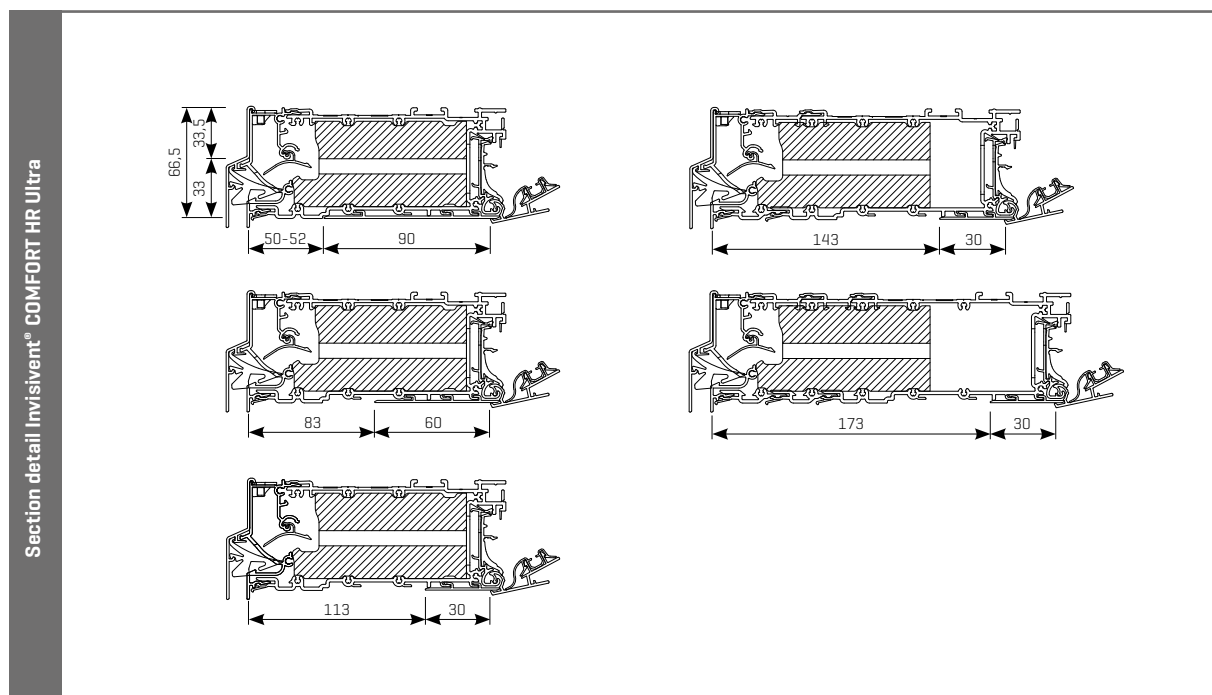

INVISIVENT® AIR / COMFORT RANGE OPTIONS



CONTROL FLAP

For ease of use or at the customer's request, the control flap is split up for lengths above 3000 mm. A special middle piece [3 mm thick] is inserted between the two flaps to give a neat finish.



FINISHING PROFILE

The Invisivent AIR/COMFORT is designed to provide a perfect finish. There is a cut-out at the top of the vent that takes plasterboard or MDF panels up to 10 mm thick, and which allows the plasterer to integrate the vent discreetly into the plastered surface.

The optional aluminium finishing profile should be used with traditional wet plastering. The profile should also be used for a perfect finish when installing a roller shutter box, for example, above the Invisivent AIR/COMFORT. This profile is available in the same finish as the inside of the Invisivent AIR/COMFORT.

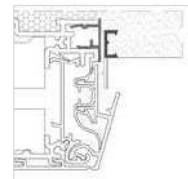
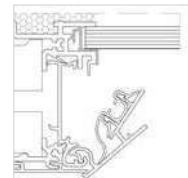

INSTALLATION USING WALL BRACKETS

The Invisivent AIR/COMFORT has a dowel slot so it can be attached quickly and easily to the unfinished structure by using wall brackets.



SPLIT UP MIDDLE PIECE

An Invisivent AIR/COMFORT is available in lengths up to 6 meter. However, it is also possible to install several Invisivent AIR/COMFORT vents next to each other, joined by a split up middle piece for a perfect finish.

RAIN CAP

In case of exposure to extreme weather conditions (rain, sand, high wind loads,...), a rain cap can be added to the Invisivent AIR/COMFORT, ensuring high comfort at all times.



SIDE MOUNTING PLATE

The use of side mounting plates is recommended to ensure that the Invisivent AIR/COMFORT fits securely to the window.

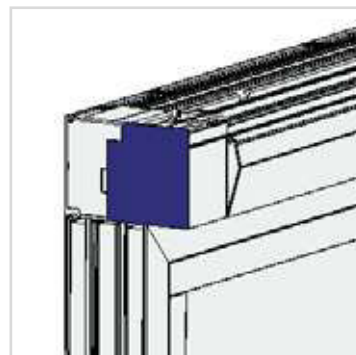

AIRFLOW LIMITERS

Airflow limiters can easily be clipped into the Invisivent AIR Basic and COMFORT. They close the opening by 100 mm so that the maximum flow can be adjusted to suit your needs.



REMOVABLE ACOUSTIC FOAM

The acoustic foam can be removed (and cleaned or substituted) from the Invisivent AIR/COMFORT through the perforated PVC profile.

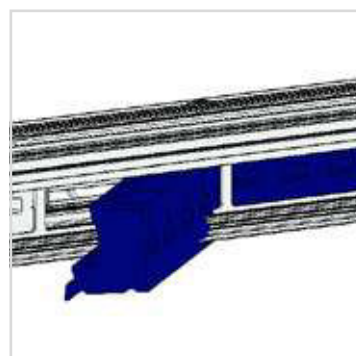

FLAP VENTILATORS GLAZED-IN/AT TRANSOM



Sonovent®



30

TC60



THM90^{EVO}



TC45

Compact flap vent with a good price/quality ratio

GLAZED-IN



AT TRANSOM

COANDA
EFFECT

THERMALLY
BROKEN

INTRODUCTION

The compact TC45 is a non-selfregulating, thermally broken aluminium glazed-in window vent with a soft-line design outer profile. The internal flap directs the incoming airflow upwards and can be placed in 5 positions.

GLAZED-IN INSTALLATION (OR AT TRANSOM)

The TC45 can be installed glazed-in, or at transom using the additional transom profiles.

THERMALLY BROKEN

No cold air transfer from outside to inside.

COANDA EFFECT

The interior profile deflects the incoming air upwards, causing an optimal spread of fresh air in the room.

INSECT MESH

The perforated inside profile acts as an insect mesh.



TECHNICAL CHARACTERISTICS

Airflow	
Equivalent area	10435 mm ² /m
Q at 1 Pa	8,2 l/s/m
Q at 1 Pa	29,5 m ³ /h/m
Q at 2 Pa	11,5 l/s/m
Q at 10 Pa	25,8 l/s/m
Q at 20 Pa	36,5 l/s/m
Comfort	
Sound reduction $D_{n,e,w}$ [C;C _{tr}]	
In open position	27 [0;0] dB
In closed position	37 [-1;-2] dB
Technical characteristics	
Controllable internal flap	5 stepped positions
Control options internal flap	Manual, cord, rod
U value	4,1 W/m ² K
Air leakage at 50 Pa	<15% [in closed position]
Watertightness in closed position, up to	650 Pa
Watertightness in open position, up to	-
Dimensions	
Glass reduction	45 mm
Height	60 mm
Glass thickness	20, 24 or 28 mm
Max. length	2500 mm



TECHNICAL DRAWINGS

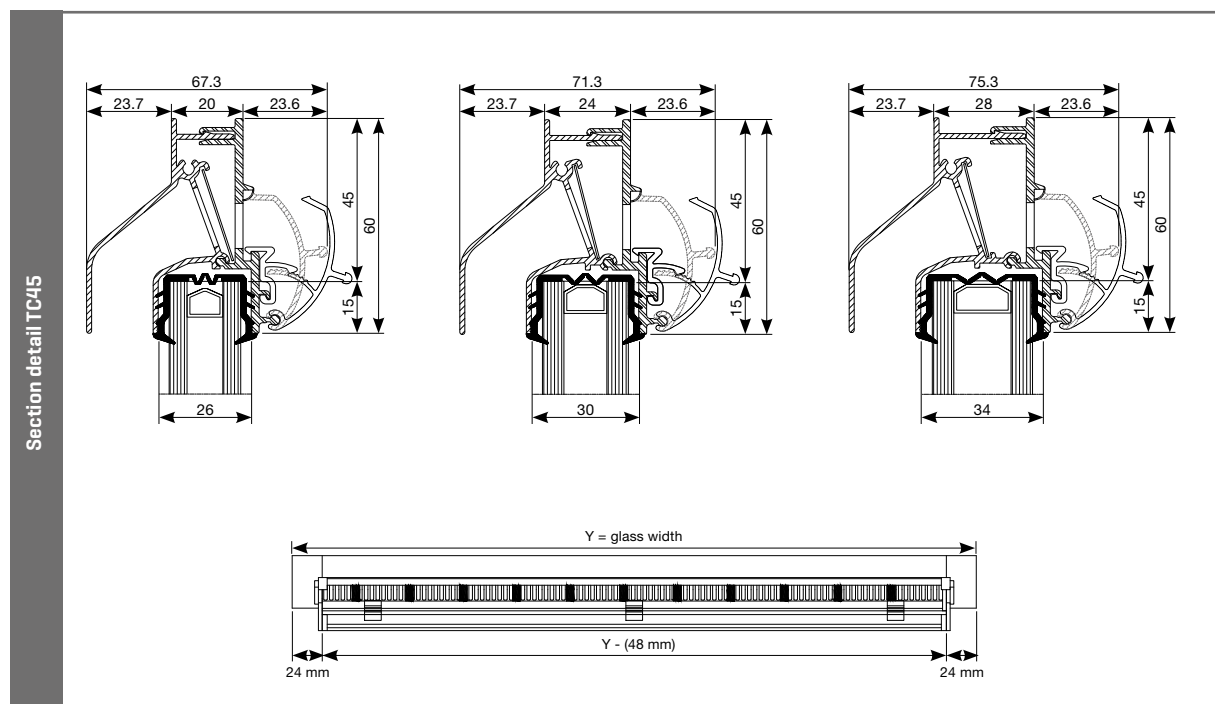

TC60

Compact flap vent with an excellent price/quality ratio

GLAZED-IN



AT TRANSOM

THERMALLY
BROKEN

PRICE
QUALITY RATIO

INTRODUCTION

The TC60 is a non-selfregulating, thermally broken aluminium glazed-in window vent with a soft-line design outer profile, having an excellent price/quality ratio. The internal flap directs the incoming airflow upwards and can be continuously controlled.

GLAZED-IN INSTALLATION (OR AT TRANSOM)

The TC60 has been developed for glazed-in installation, and can be integrated in aluminium, timber and PVC window profiles with a depth of 20, 24 or 28 mm. The TC60 can optionally also be installed at transom, using the additional transom profiles.

THERMALLY BROKEN

No cold air transfer from outside to inside.

EXCELLENT PRICE/QUALITY RATIO

Qualitative and compact window vent, ensuring the supply of fresh air, with an excellent price / quality ratio.

INSECT MESH

The perforated inside profile acts as an insect mesh.



TECHNICAL CHARACTERISTICS

Airflow	
Equivalent area	15652 mm ² /m
Q at 1 Pa	12,3 l/s/m
Q at 1 Pa	44,3 m ³ /h/m
Q at 2 Pa	17,4 l/s/m
Q at 10 Pa	38,9 l/s/m
Q at 20 Pa	55,0 l/s/m
Comfort	
Sound reduction $D_{n,e,w}$ [C;C _{tr}]	
In open position	28 [0;0] dB
In closed position	42 [0;0] dB
Technical characteristics	
Controllable internal flap	continuous adjustment
Control options internal flap	Manual, cord, rod
U value	3,3 W/m ² K
Air leakage at 50 Pa	<15% [in closed position]
Watertightness in closed position, up to	650 Pa
Watertightness in open position, up to	10 Pa
Dimensions	
Glass reduction	60 mm
Height	75 mm
Glass thickness	20, 24 or 28 mm
Max. length	2500 mm



TECHNICAL DRAWINGS

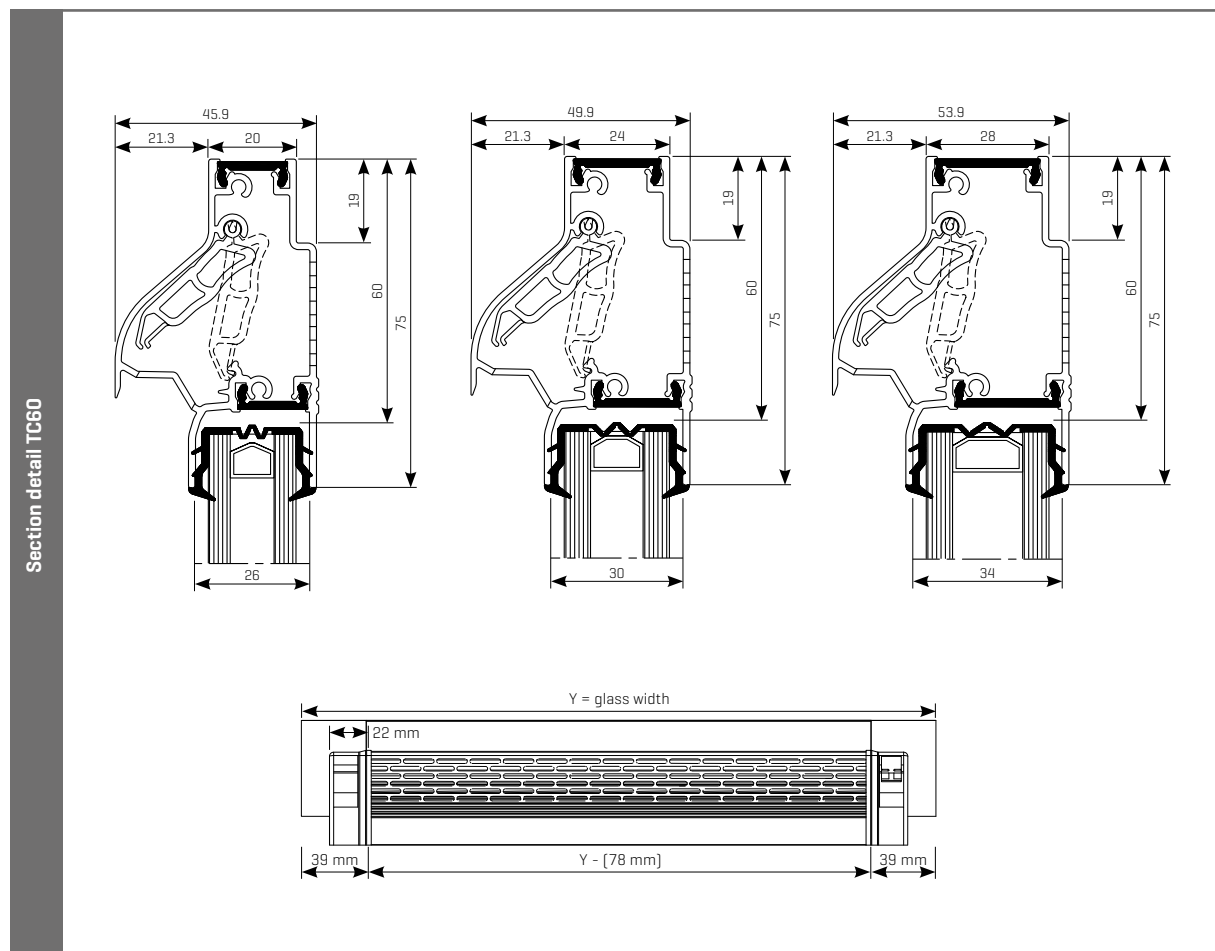

AR60

Self-regulating flap vent with external hood for improved weather protection

GLAZED-IN



AT TRANSOM

SELF-REGULATING

I-FLUX



INTRODUCTION

The interior profile of the AR60 deflects the incoming air upwards so that fresh air is optimally spread in the room. It also has an external hood for additional weather protection. The AR60 is also available with permanently open clips (e.g. for open gas appliances).

GLAZED-IN INSTALLATION (OR AT TRANSOM)

The AR60 has been developed for glazed-in installation, and can be integrated in aluminium, timber and PVC window profiles with a depth of 20, 24 or 28 mm. The AR60 can optionally also be installed at transom, using the additional transom profiles.

THERMALLY BROKEN

No cold air transfer from outside to inside.

I-FLUX®

Thanks to its self-regulating flap, the AR60 ensures the supply of fresh and healthy air without draughts. Moreover, the interior profile deflects the incoming air upwards, causing an optimal spread of fresh air in the room.

INSECT MESH

The perforated inside profile acts as an insect mesh.

TECHNICAL CHARACTERISTICS

Airflow	
Equivalent area	10427 mm ² /m
Q at 1 Pa	8,2 l/s/m
Q at 1 Pa	29,5 m ³ /h/m
Q at 2 Pa	11,8 l/s/m
Q at 10 Pa	19,7 l/s/m
Q at 20 Pa	23,9 l/s/m
Comfort	
Sound reduction $D_{n,e,w}$ [C;C _{tr}]	
In open position	27 [0;0] dB
In closed position	44 [0;0] dB
Technical characteristics	
Controllable internal flap	5 stepped positions
Control options internal flap	Manual, cord, rod
U value	4,5 W/m ² K
Air leakage at 50 Pa	<15% [in closed position]
Watertightness in closed position, up to	650 Pa
Watertightness in open position, up to	100 Pa
Dimensions	
Glass reduction	60 mm
Height	76 mm
Glass thickness	20, 24 or 28 mm
Max. length	2500 mm



TECHNICAL DRAWINGS

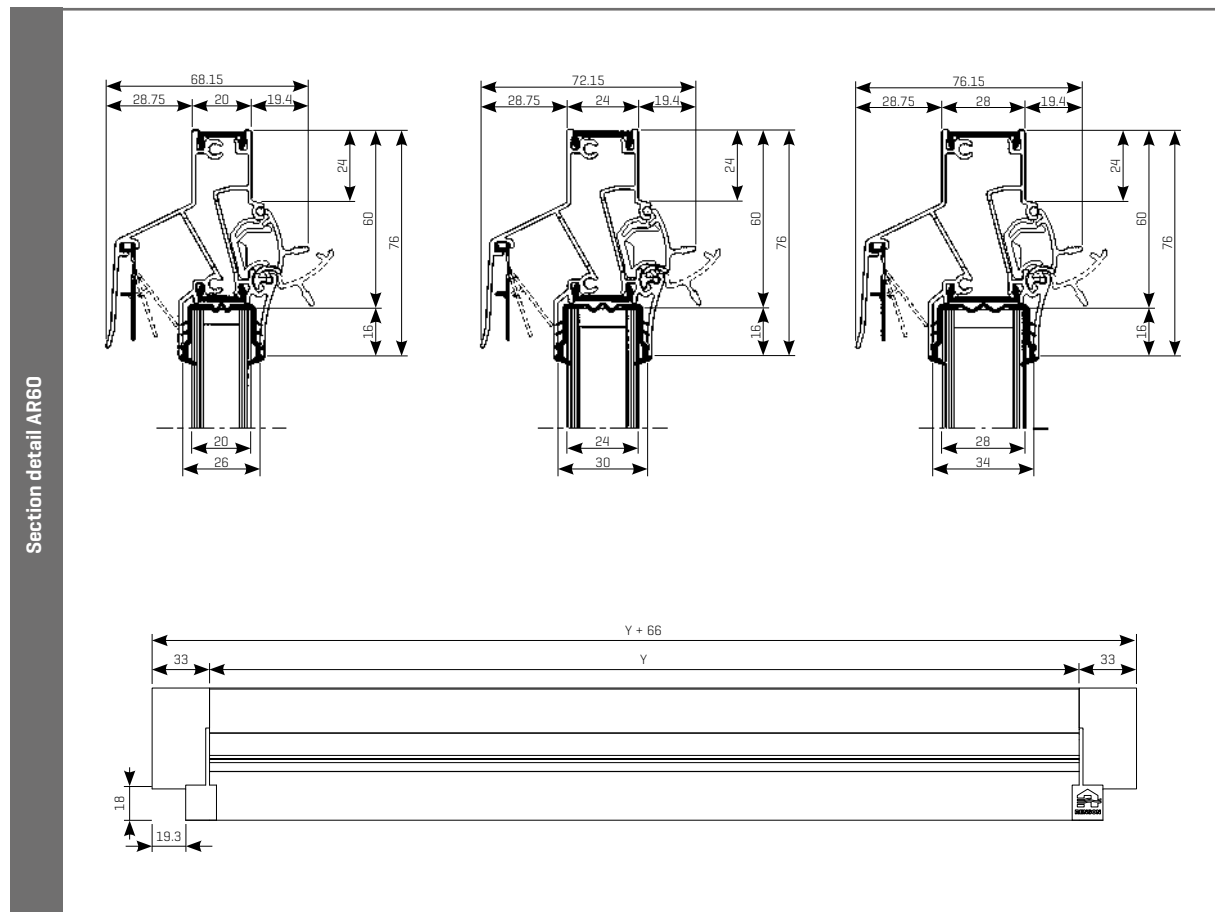

THK60

Flap vent with external hood for improved weather protection

GLAZED-IN



AT TRANSOM

COANDA
EFFECT

THERMALLY
BROKEN

INTRODUCTION

The THK60 is a thermally broken, slimline glazed-in ventilator for application in aluminium, timber and PVC windows. The internal tip directs the flow of incoming air upwards, and can be placed in 5 positions.

The THK60 is also available with permanently open clips (e.g. for open gas appliances).

GLAZED-IN INSTALLATION (OR AT TRANSOM)

The THK60 has been developed for glazed-in installation, and can be integrated in aluminium, timber and PVC window profiles with a depth of 20, 24 or 28 mm. The THK60 can optionally also be installed at transom, using the additional transom profiles.

THERMALLY BROKEN

No cold air transfer from outside to inside.

COANDA EFFECT

The interior profile deflects the incoming air upwards, causing an optimal spread of fresh air in the room.

INSECT MESH

The perforated inside profile acts as an insect mesh.



TECHNICAL CHARACTERISTICS

Airflow	
Equivalent area	11841 mm ² /m
Q at 1 Pa	9,3 l/s/m
Q at 1 Pa	33,5 m ³ /h/m
Q at 2 Pa	13,2 l/s/m
Q at 10 Pa	29,6 l/s/m
Q at 20 Pa	41,8 l/s/m
Comfort	
Sound reduction $D_{n,e,w}$ [C;C _{tr}]	
In open position	27 [0;0] dB
In closed position	44 [0;0] dB
Technical characteristics	
Controllable internal flap	5 stepped positions
Control options internal flap	Manual, cord, rod
U value	4,5 W/m ² K
Air leakage at 50 Pa	<15% [in closed position]
Watertightness in closed position, up to	650 Pa
Watertightness in open position, up to	100 Pa
Dimensions	
Glass reduction	60 mm
Height	76 mm
Glass thickness	20, 24 or 28 mm
Max. length	2500 mm



TECHNICAL DRAWINGS

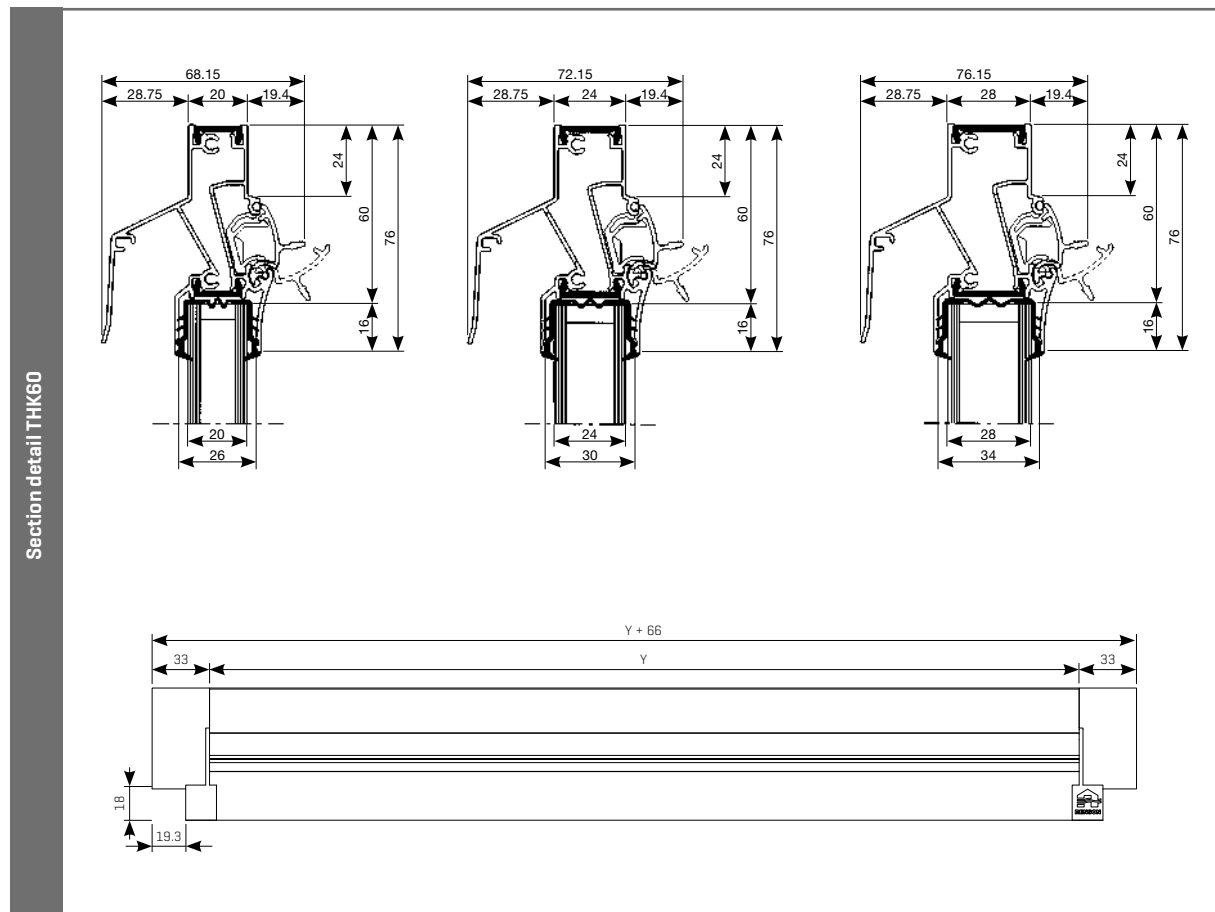

AR75

Excellent self-regulating window vent with 4 different airflows in 1 design

GLAZED-IN



AT TRANSOM

SELF-REGULATING

4 AIRFLOWS
IN 1 DESIGN

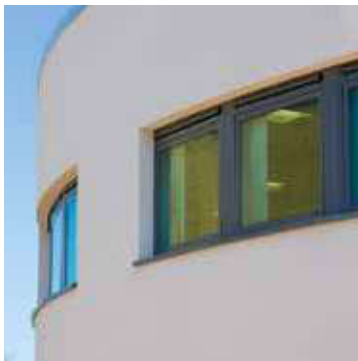

INTRODUCTION

Due to its unique patented inner mechanism, 4 different airflow levels can be reached while the AR75 visually maintains the same look.

GLAZED-IN INSTALLATION (OR AT TRANSOM)

The AR75 has been developed for glazed-in installation, and can be integrated in aluminium, timber and PVC window profiles. This vent can also be installed at transom using an additional transom profile.

THERMALLY BROKEN

No cold air transfer from outside to inside.

SELF-REGULATING

Thanks to its self-regulating flap, the AR75 ensures the supply of fresh and healthy air without draughts.

4 DIFFERENT AIRFLOW LEVELS WITH 1 SINGLE DESIGN

Due to its internal mechanism, the AR75 can obtain 4 different airflow levels. This allows to use the same vent [visually] in order to provide different rooms, each with their specific ventilation needs, with fresh air.

INSECT MESH

The perforated inside profile acts as an insect mesh.

TECHNICAL CHARACTERISTICS

	Small	Medium	Large	XLarge
Airflow				
Equivalent area	14174 mm ² /m	17409 mm ² /m	19034 mm ² /m	24301 mm ² /m
Q at 1 Pa	11,1 l/s/m	13,7 l/s/m	15,0 l/s/m	19,1 l/s/m
Q at 1 Pa	40,1 m ³ /h/m	49,3 m ³ /h/m	53,9 m ³ /h/m	68,8 m ³ /h/m
Q at 2 Pa	15,3 l/s/m	18,8 l/s/m	22,6 l/s/m	29,0 l/s/m
Q at 10 Pa	17,3 l/s/m	21,4 l/s/m	24,5 l/s/m	31,5 l/s/m
Q at 20 Pa	14,7 l/s/m	18,9 l/s/m	21,7 l/s/m	28,0 l/s/m
Comfort				
Sound reduction $D_{n,e,w}$ [C;C _v]				
In open position	26 [-1;-1] dB	26 [-1;-2] dB	26 [-1;-2] dB	26 [-1;-1] dB
In closed position	43 [-1;-1] dB	43 [-1;-1] dB	43 [-1;-1] dB	43 [-1;-1] dB
Technical characteristics				
Controllable internal flap	Continuous adjustment			
Control options internal flap	Manual, cord, rod, motor			
U value	3,0 W/m ² K			
Air leakage at 50 Pa	<15% (in closed position)			
Watertightness in closed position, up to	650 Pa			
Watertightness in open position, up to	50 Pa			
Dimensions				
Glass reduction	75 mm [glass thickness: 20, 24, 28, and 32 mm] / 77 mm [glass thickness 36, 40 and 44 mm]			
Height	92 mm			
Glass thickness	20, 24, 28, 32*, 36*, 40*, 44* mm			20, 24, 28, 32*, 36* mm
Max. length	2500 mm			

* not for installation at transom

TECHNICAL DRAWINGS

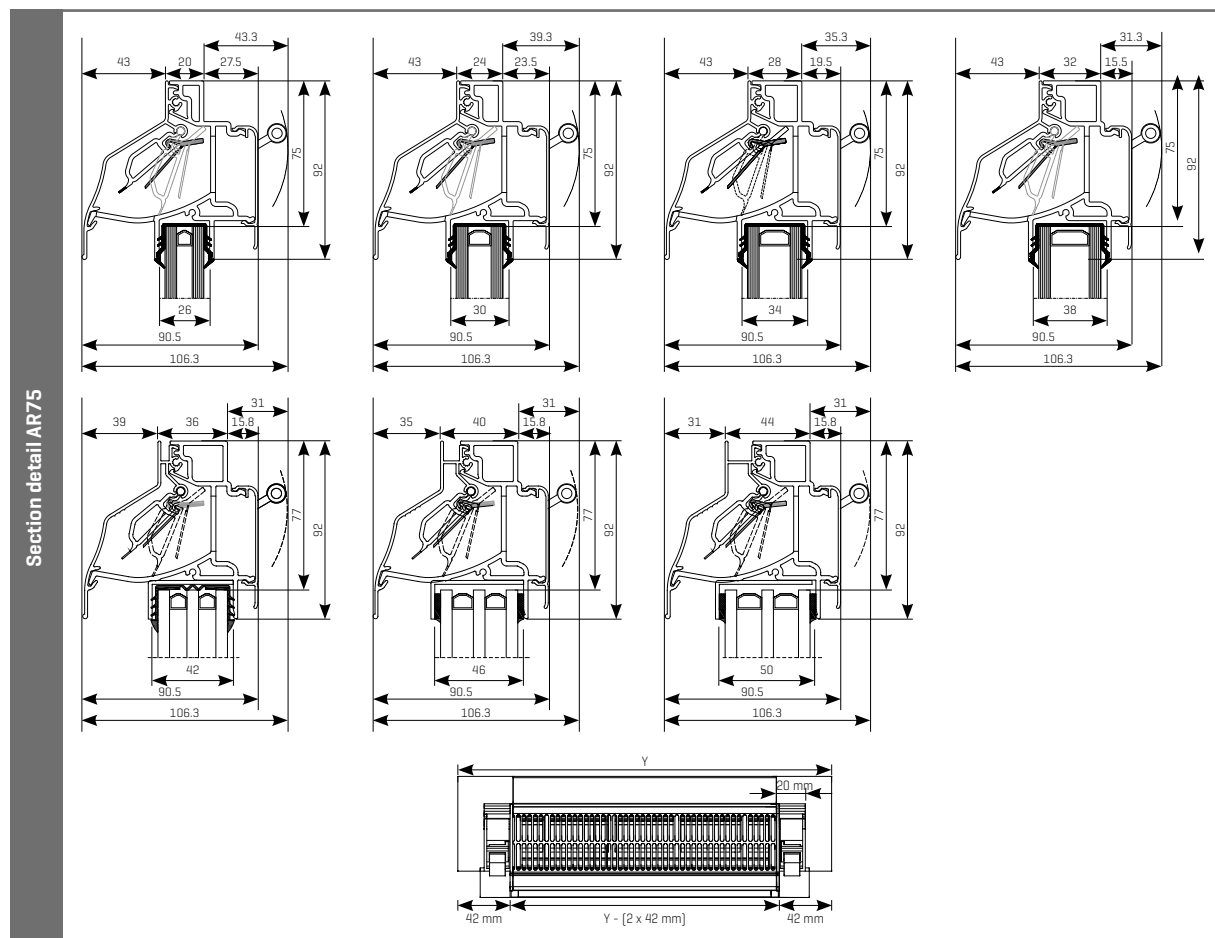

AR90

Self-regulating flap vent with external hood for improved weather protection

- FLAT INTERIOR PROFILE
- SELF-REGULATING
- GLAZED-IN
- AT TRANSOM



INTRODUCTION

The AR90 is the self-regulating version of the THK90. A self-regulating flap is integrated, reacting automatically to various wind pressures and thus preventing draughts. As the THK90, the AR90 has an external hood for additional weather protection.

GLAZED-IN INSTALLATION (OR AT TRANSOM)

The AR90 has been developed for glazed-in installation, and can be integrated in aluminium, timber and PVC window profiles with a depth of 20, 24 or 28 mm. The AR90 can optionally also be installed at transom, using the additional transom profiles.

THERMALLY BROKEN

No cold air transfer from outside to inside.

SELF-REGULATING

Thanks to its self-regulating flap, the AR90 ensures the supply of fresh and healthy air without draughts.

FLAT INTERIOR PROFILE

Thanks to its flat interior profile, the AR90 is the ideal solution for integration in the fixed part of sash windows.

INSECT MESH

The perforated inside profile acts as an insect mesh.

TECHNICAL CHARACTERISTICS

Airflow	
Equivalent area	14252 mm ² /m
Q at 1 Pa	11,2 l/s/m
Q at 1 Pa	40,3 m ³ /h/m
Q at 2 Pa	15,6 l/s/m
Q at 10 Pa	11,4 l/s/m
Q at 20 Pa	9,1 l/s/m
Comfort	
Sound reduction $D_{n,e,w}$ [C;C _{tr}]	
In open position	30 [-1;-2] dB
In closed position	45 [-1;-3] dB
Technical characteristics	
Controllable internal flap	5 stepped positions
Control options internal flap	Manual, cord, rod, motor
U value	3,9 W/m ² K
Air leakage at 50 Pa	<15% [in closed position]
Watertightness in closed position, up to	650 Pa
Watertightness in open position, up to	100 Pa
Dimensions	
Glass reduction	90 mm
Height	105 mm
Glass thickness	20, 24 or 28 mm
Max. length	2500 mm [2000 mm for motorised control]



TECHNICAL DRAWINGS

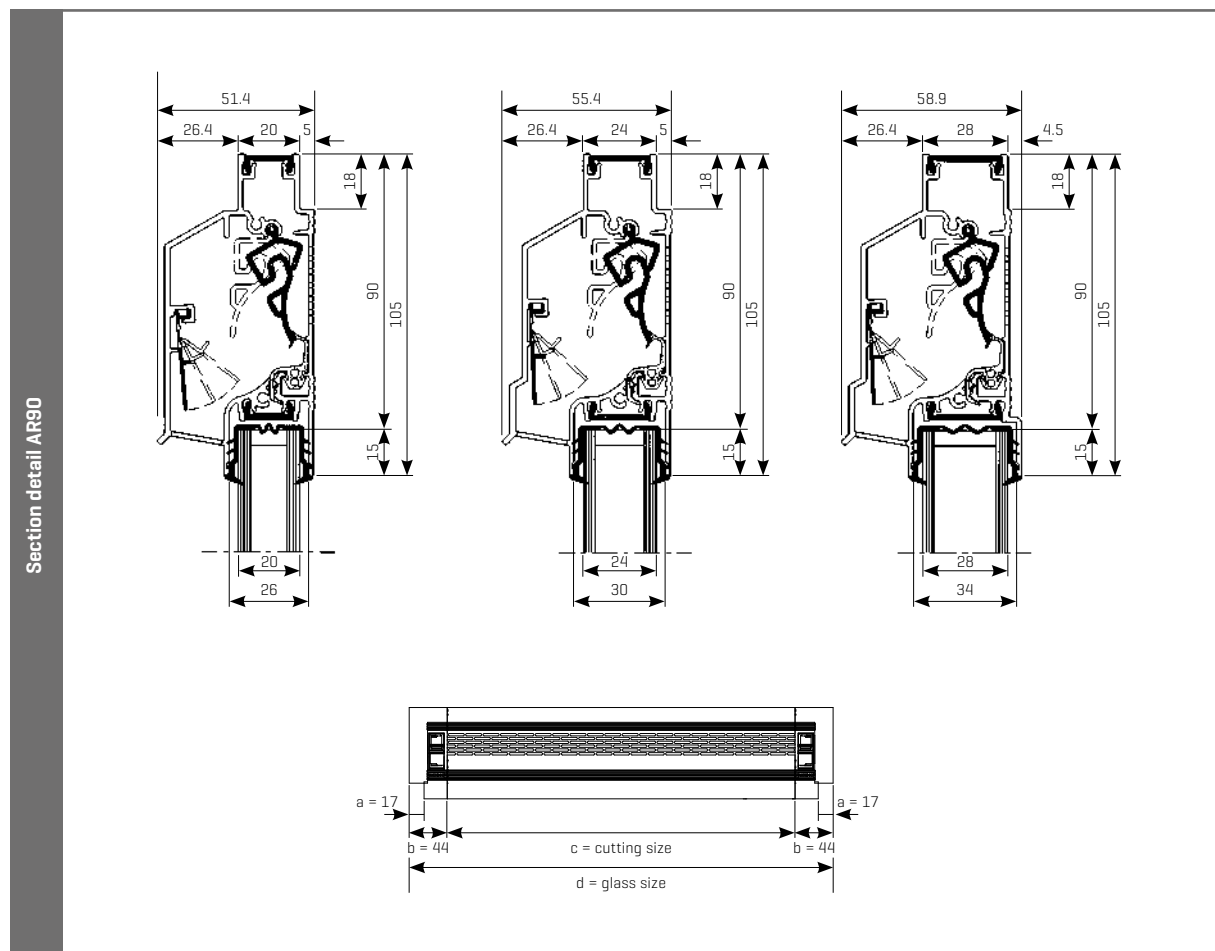

THK90

Flap vent with external hood for improved weather protection

FLAT INTERIOR
PROFILE

GLAZED-IN

AT TRANSOM

THERMALLY
BROKEN



INTRODUCTION

The non self-regulating THK90 has a flat interior profile, which makes it a good solution for the integration in the fixed part of sash windows. The THK90 also has an external hood for additional weather protection.

GLAZED-IN INSTALLATION (OR AT TRANSOM)

The THK90 has been developed for glazed-in installation, and can be integrated in aluminium, timber and PVC window profiles with a depth of 20, 24 or 28 mm. The THK90 can optionally also be installed at transom, using the additional transom profiles.

THERMALLY BROKEN

No cold air transfer from outside to inside.

FLAT INTERIOR PROFILE

Thanks to its flat interior profile, the THK90 is a good solution for integration in the fixed part of sash windows.

INSECT MESH

The perforated inside profile acts as an insect mesh.

TECHNICAL CHARACTERISTICS

Airflow	
Equivalent area	14736 mm ² /m
Q at 1 Pa	11,6 l/s/m
Q at 1 Pa	41,7 m ³ /h/m
Q at 2 Pa	16,1 l/s/m
Q at 10 Pa	34,5 l/s/m
Q at 20 Pa	48,0 l/s/m
Comfort	
Sound reduction $D_{n,e,w}$ [C;C _{tr}]	
In open position	28 [0;-1] dB
In closed position	44 [0;-1] dB
Technical characteristics	
Controllable internal flap	5 stepped positions
Control options internal flap	Manual, cord, rod, motor
U value	3,9 W/m ² K
Air leakage at 50 Pa	<15% (in closed position)
Watertightness in closed position, up to	650 Pa
Watertightness in open position, up to	50 Pa
Dimensions	
Glass reduction	90 mm
Height	105 mm
Glass thickness	20, 24 or 28 mm
Max. length	2500 mm [2000 mm for motorised control]



TECHNICAL DRAWINGS

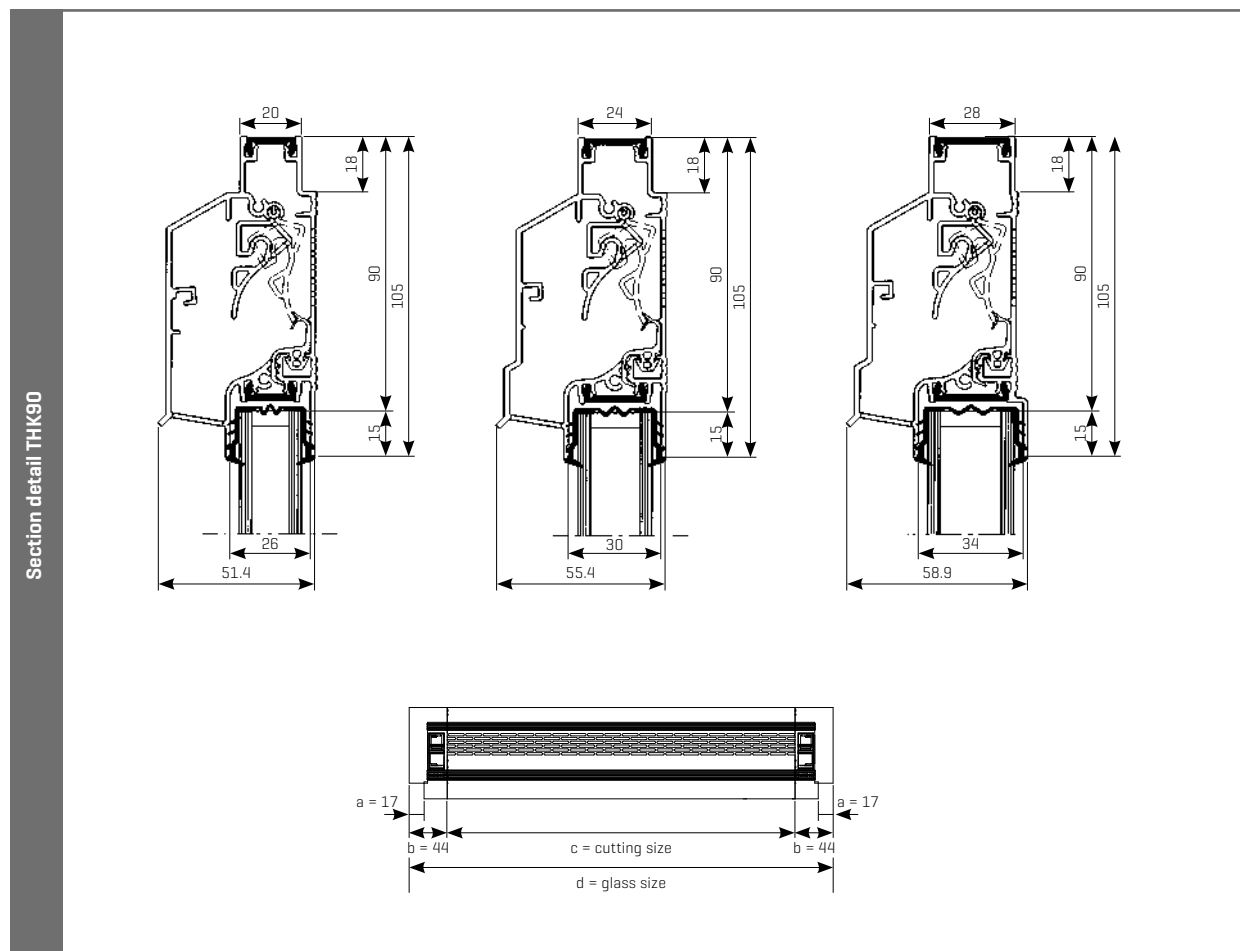

THM90^{EVO}/THM90PB^{EVO}/THM90TR^{EVO}

Self-regulating flush window vent, ideal for sliding doors

ENTIRELY FLAT
PROFILES

GLAZED-IN

AT TRANSOM

SELF-
REGULATING



INTRODUCTION

The THM90^{EVO} is an entirely flat window vent, which makes this the ideal product for integration in sliding doors. Three different types of THM90^{EVO} are available, each for different glass thicknesses: THM90^{EVO} for glazed-in installation, THM90PB^{EVO} for installation at the bottom of the window, and the THM90TR^{EVO} for installation between profiles [at transom].

By combining a THM90PB^{EVO} in the lower part and a THM90^{EVO} in the upper part of a conservatory, the THM90^{EVO} is ideal for natural ventilation by convection.

GLAZED-IN INSTALLATION (OR AT TRANSOM)

The THM90^{EVO} has been developed for glazed-in installation, and can be integrated in aluminium, timber and PVC window profiles. The THM90^{EVO} can be installed on glass, at the bottom of the window [THM90PB^{EVO}], and at transom [THM90TR^{EVO}]. The THM90^{EVO} should only be used for installation on ground floors.

THERMALLY BROKEN

No cold air transfer from outside to inside.

SELF-REGULATING

Thanks to its self-regulating flap, the THM90^{EVO} ensures the supply of fresh and healthy air without draughts.

ENTIRELY FLAT PROFILES

Thanks to its flat profiles, the THM90^{EVO} is the perfect solution for integration in sash windows.

INSECT MESH

The perforated inside profile acts as an insect mesh.

TECHNICAL CHARACTERISTICS

Airflow	
Equivalent area	11841 mm ² /m
Q at 1 Pa	9,3 l/s/m
Q at 1 Pa	33,5 m ³ /h/m
Q at 2 Pa	13,9 l/s/m
Q at 10 Pa	13,5 l/s/m
Q at 20 Pa	15,1 l/s/m
Comfort	
Sound reduction $D_{n,e,w}$ [C;C _{tr}]	
In open position	26 [0;0] dB
In closed position	45 [-1;-1] dB
Technical characteristics	
Controllable internal flap	5 stepped positions
Control options internal flap	Manual, cord, rod, motor
U value	3,8 W/m ² K
Air leakage at 50 Pa	<15% [in closed position]
Watertightness in closed position, up to	650 Pa
Watertightness in open position, up to	100 Pa
Dimensions	
Glass reduction	90 mm
Height	105 mm
Glass thickness	
THM90 ^{EVO}	20, 24, 28 or 33 mm
THM90PB ^{EVO}	20, 24 or 28 mm
THM90TR ^{EVO}	20 or 24 mm
Max. length	2500 mm [2000 mm for motorised control]



TECHNICAL DRAWINGS

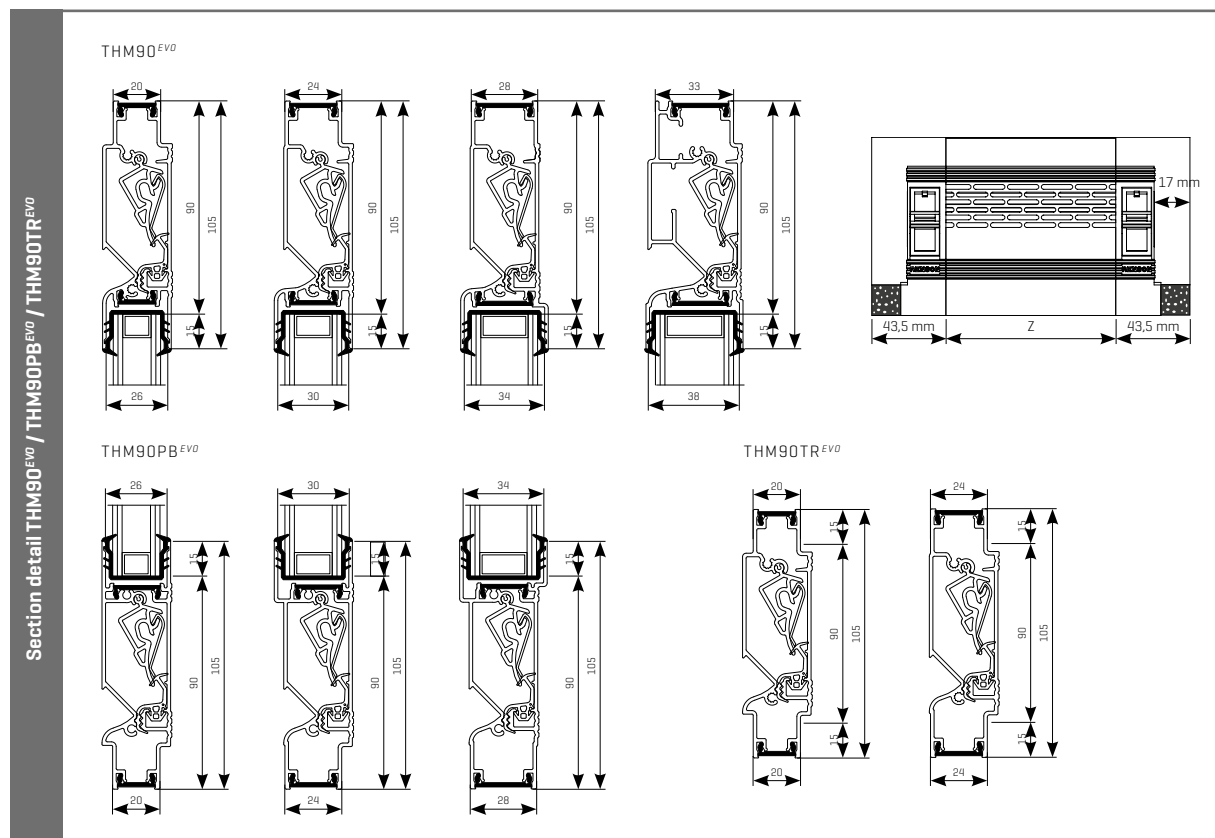

SONOVENT®

Self-regulating flap ventilator with a superior sound absorption

AT TRANSOM

GLAZED-IN

SELF-REGULATING

SOUND ABSORPTION

16 ALTERNATIVES



INTRODUCTION

Renson® has developed the Sonovent range to meet with two aspects of living comfort:

- physical comfort: fresh and healthy air without draughts
- acoustic comfort: up to 56 dB sound reduction

The Sonovent is an extensive range of self-regulating window vents with a superior air sound insulation. Four types of the Sonovent are available; Small, Medium, Large and Xlarge, each model having 4 different air slot possibilities [10, 15, 20 or 25 mm]. This comes up to 16 alternatives in total, each model with a different airflow and sound reduction. Furthermore, thermal breaks can be positioned differently, depending on the model and installation method. The Sonovent range therefore offers an ideal solution for every situation.

GLAZED-IN, AT TRANSOM OR ROOF INSTALLATION

The Sonovent is preferably placed at transom. By adding L-profiles to the upper and lower side, the Sonovent can also be placed on glass. The Sonovent can be used for slant roofs with a minimal slope of 22,5° in order to avoid water infiltration.

Importantly, the entire length of the Sonovent for roof installation has to be covered with ventilation tiles.

CURTAIN WALL SYSTEM

Integration in curtain walls is possible. Our presales team will provide you with the necessary details.

THERMALLY BROKEN

No cold air-transfer from outside to inside. Thermal breaks can be positioned differently depending on the model and installation method.

SELF-REGULATING

Thanks to its self-regulating flap, the Sonovent ensures the supply of fresh and healthy air without draughts.

SOUND ABSORPTION

Various sound reduction levels (depending on the type), from 37dB up to 56 dB.

INSECT MESH

The perforated inside profile acts as an insect mesh.

TECHNICAL DRAWINGS

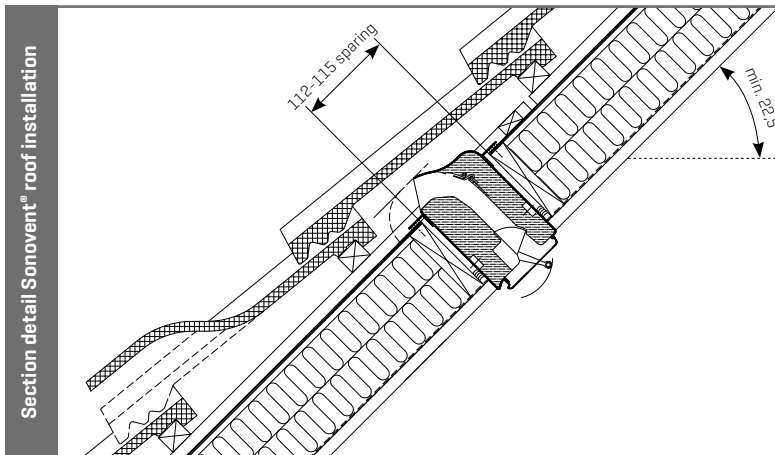
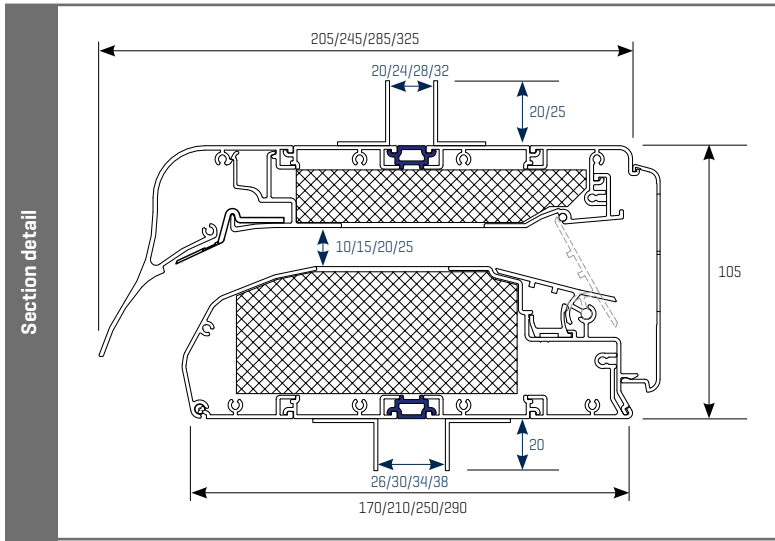

INSTALLATION

The Sonovent is designed to be installed glazed-in or at transom (preferred installation). Hidden installation behind louvres or in a ventilated panel of a curtain wall system is also possible and commonly applied in offices, schools, ...

By choosing the right model of Sonovent and varying the length, the required airflow together with the necessary acoustic performances can be reached.

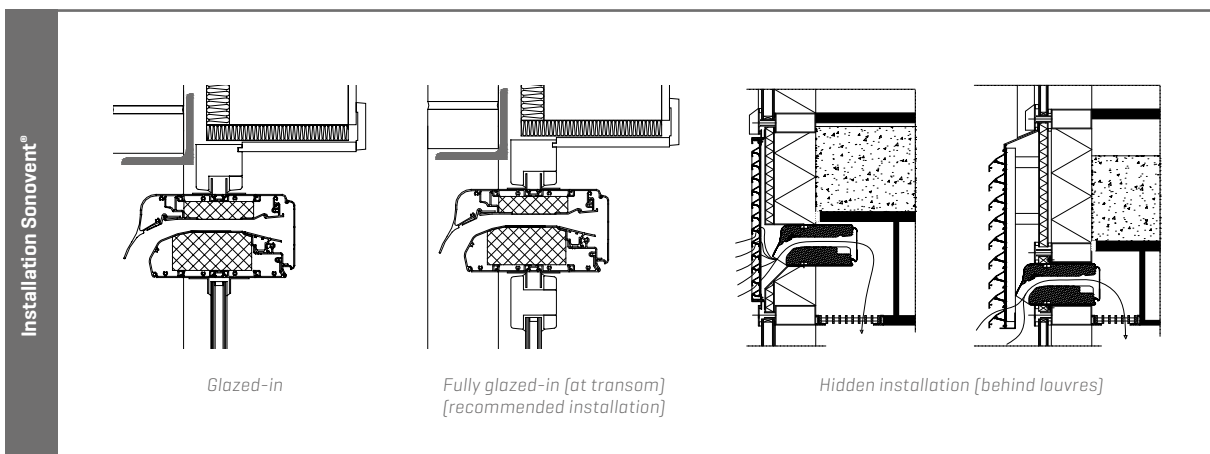

SONOVENT®

Self-regulating flap ventilator with a superior sound absorption

THE VERSATILE SONOVENT® - RANGE

4 different models with different positions of the thermal break

- Models: **Small - Medium - Large - XLarge** [XSmall and XXLarge on demand]
- Thermal break: different positions **1 to 6**

Models Sonovent®

Possible positions of the thermal break			
	Glazed-in	At transom	Hidden installation
Small	1 - 2 - 3	1 - 2 - 3	1 - 2 - 3
Medium	2 - 3 - 4	1 - 2 - 3 - 4	1 - 2 - 3 - 4
Large	2 - 3 - 4	1 - 2 - 3 - 4	1 - 2 - 3 - 4 - 5*
XLarge	3* - 4*	2 - 3 - 4	1 - 2 - 3 - 4 - 5* - 6*

* On demand

Airslot openings

- Airslot opening: **10 - 15 - 20 - 25 mm**

Airslot opening 10 mm
Airslot opening 15 mm
Airslot opening 20 mm
Airslot opening 25 mm

TECHNICAL CHARACTERISTICS

	Small	Medium	Large	XLarge
Airflow				
Equivalent area				
Air slot 10 mm	17756 mm ² /m	17509 mm ² /m	16153 mm ² /m	14427 mm ² /m
Air slot 15 mm	29593 mm ² /m	26511 mm ² /m	25524 mm ² /m	21578 mm ² /m
Air slot 20 mm	31813 mm ² /m	33292 mm ² /m	32059 mm ² /m	31073 mm ² /m
Air slot 25 mm	33786 mm ² /m	34032 mm ² /m	33416 mm ² /m	32676 mm ² /m
Roof installation	31070 mm ² /m			
Q at 1 Pa				
Air slot 10 mm	14,0 l/s/m	13,8 l/s/m	12,7 l/s/m	11,3 l/s/m
Air slot 15 mm	23,3 l/s/m	20,8 l/s/m	20,1 l/s/m	17,0 l/s/m
Air slot 20 mm	25,0 l/s/m	26,2 l/s/m	25,2 l/s/m	24,4 l/s/m
Air slot 25 mm	26,6 l/s/m	26,7 l/s/m	26,3 l/s/m	25,7 l/s/m
Roof installation	24,4 l/s/m			
Q at 1 Pa				
Air slot 10 mm	50,2 m ³ /h/m	49,5 m ³ /h/m	45,7 m ³ /h/m	40,8 m ³ /h/m
Air slot 15 mm	83,7 m ³ /h/m	75,0 m ³ /h/m	72,2 m ³ /h/m	61,0 m ³ /h/m
Air slot 20 mm	90,0 m ³ /h/m	94,2 m ³ /h/m	90,7 m ³ /h/m	87,9 m ³ /h/m
Air slot 25 mm	95,6 m ³ /h/m	96,3 m ³ /h/m	94,5 m ³ /h/m	92,4 m ³ /h/m
Roof installation	87,9 m ³ /h/m			
Q at 2 Pa				
Air slot 10 mm	14,0 l/s/m	13,8 l/s/m	12,7 l/s/m	11,3 l/s/m
Air slot 15 mm	23,3 l/s/m	20,8 l/s/m	20,1 l/s/m	17,0 l/s/m
Air slot 20 mm	25,0 l/s/m	26,2 l/s/m	25,2 l/s/m	24,4 l/s/m
Air slot 25 mm	26,6 l/s/m	26,7 l/s/m	26,3 l/s/m	25,7 l/s/m
Roof installation	28,0 l/s/m			
Q at 10 Pa				
Air slot 10 mm	15,3 l/s/m	15,1 l/s/m	14,0 l/s/m	12,5 l/s/m
Air slot 15 mm	25,6 l/s/m	22,9 l/s/m	22,1 l/s/m	18,7 l/s/m
Air slot 20 mm	27,5 l/s/m	28,8 l/s/m	27,7 l/s/m	26,9 l/s/m
Air slot 25 mm	29,2 l/s/m	29,4 l/s/m	28,9 l/s/m	28,2 l/s/m
Roof installation	30,8 l/s/m			
Q at 20 Pa				
Air slot 10 mm	22,9 l/s/m	-	-	-
Air slot 15 mm	28,5 l/s/m	-	-	-
Air slot 20 mm	29,2 l/s/m	-	-	-
Air slot 25 mm	27,1 l/s/m	27,5 l/s/m	25,0 l/s/m	-
Roof installation	34,8 l/s/m			
Comfort				
Sound reduction $D_{n,e,w}$ [C;C _{tr}] In open position				
Air slot 10 mm	46 [-1;-5] dB	48 [-2;-6] dB	50 [-2;-6] dB	56 [-2;-6] dB
Air slot 15 mm	41 [-1;-2] dB	45 [-2;-6] dB	49 [-2;-7] dB	53 [-2;-6] dB
Air slot 20 mm	40 [-1;-3] dB	43 [0;-3] dB	44 [-2;-6] dB	46 [-2;-6] dB
Air slot 25 mm	37 [-1;-3] dB	39 [-1;-4] dB	41 [-2;-6] dB	45 [-2;-6] dB
Roof installation	37 [-1;-3] dB	39 [-1;-4] dB	41 [-2;-6] dB	45 [-2;-6] dB
Sound reduction $D_{n,e,w}$ [C;C _{tr}] in closed position				
-				
Technical characteristics				
Controllable internal flap	Continuous adjustment			
Control options internal flap	Manual, cord, rod, motor			
U value	4,5 W/m ² K	4,6 W/m ² K	4,6 W/m ² K	4,7 W/m ² K
Air leakage at 50 Pa	<15% [in closed position]			
Watertightness in closed position, up to	650 Pa			
Watertightness in open position, up to	50 Pa			
Dimensions				
Height	105 mm [box height] / 155 mm [total height with flanges]			
Roof thickness	170 mm	210 mm	250 mm	290 mm
Minimal slope	22,5°			
Roof opening	115 mm			
Max. length	1000 mm			

SONOVENT® COMPACT

Compact self-regulating acoustic flap ventilator

GLAZED-IN



AT TRANSOM



SELF-REGULATING

SOUND ABSORPTION

COMPACT

3 AIRFLOWS WITHIN 1 MODEL

INTRODUCTION

The Sonovent Compact is a self-regulating and acoustic window vent for glazed-in installation (or at transom using an additional transom profile). This compact sound absorbing window vent offers an excellent compromise between acoustic performance and airflow. The Sonovent Compact has 3 different air slot possibilities (10, 13 or 15 mm), so three different airflows can be obtained within a single model.

GLAZED-IN INSTALLATION (OR AT TRANSOM)

The Sonovent Compact can be installed glazed-in or at transom (using the additional transom profiles).

THERMALLY BROKEN

No cold air transfer from outside to inside.

SELF-REGULATING

Thanks to its self-regulating flap, the Sonovent Compact ensures the supply of fresh and healthy air without draughts.

THREE DIFFERENT AIRFLOW LEVELS IN ONE MODEL

The Sonovent Compact has 3 different air slot possibilities (10, 13 or 15 mm), so three different airflows can be obtained within a single model.

SOUND ABSORPTION

Various sound reduction levels (depending on the type), from 33 dB up to 36 dB.

INSECT MESH

The perforated inside profile acts as an insect mesh.

TECHNICAL CHARACTERISTICS

Airflow	
Equivalent area	
Air slot 10 mm	15334 mm ² /m
Air slot 13 mm	19278 mm ² /m
Air slot 15 mm	24687 mm ² /m
Q at 1 Pa	
Air slot 10 mm	12,1 l/s/m
Air slot 13 mm	15,2 l/s/m
Air slot 15 mm	19,4 l/s/m
Q at 1 Pa	
Air slot 10 mm	43,4 m ³ /h/m
Air slot 13 mm	54,5 m ³ /h/m
Air slot 15 mm	69,8 m ³ /h/m
Q at 2 Pa	
Air slot 10 mm	16,4 l/s/m
Air slot 13 mm	18,8 l/s/m
Air slot 15 mm	19,9 l/s/m
Q at 10 Pa	
Air slot 10 mm	17,3 l/s/m
Air slot 13 mm	18,8 l/s/m
Air slot 15 mm	18,6 l/s/m
Q at 20 Pa	
Air slot 10 mm	17,8 l/s/m
Air slot 13 mm	18,7 l/s/m
Air slot 15 mm	19,1 l/s/m
Comfort	
Sound reduction $D_{n,e,w}$ [C;C _v] In open position	
Air slot 10 mm	36 [0;-1] dB
Air slot 13 mm	35 [0;-1] dB
Air slot 15 mm	33 [0;-1] dB
Sound reduction $D_{n,e,w}$ [C;C _v] in closed position	
	-
Technical characteristics	
Controllable internal flap	Continuous adjustment
Control options internal flap	Manual, cord, rod, motor
U value	6,0 W/m ² K
Air leakage at 50 Pa	<15% [in closed position]
Watertightness in closed position, up to	650 Pa
Watertightness in open position, up to	150 Pa
Dimensions	
Glass reduction	78 mm
Height	75 mm [box height] / 95 mm [total height with flanges]
Glass thickness	20, 24, 28, 32 or 36 mm
Max. length	2000 mm [glazed-in] or 2500 mm [at transom]



TECHNICAL DRAWINGS

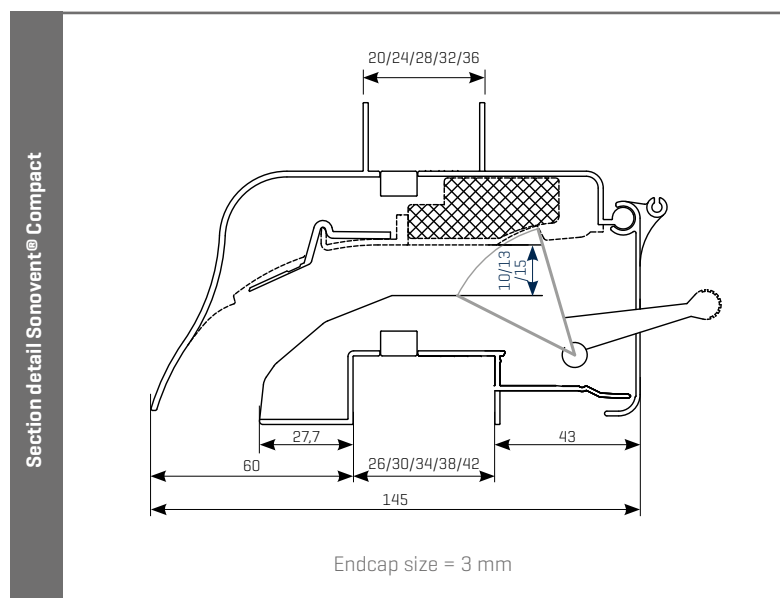

ROLLER SHUTTER FLAP VENTILATOR





TRANSIVENT®

Self-regulating ventilator for installation in roller shutters

FOR ROLLER SHUTTERS

SELF-REGULATING

THERMALLY BROKEN

I-FLUX



INTRODUCTION

The Transivent is a self-regulating, thermally broken ventilator with an attractive design, for mounting in a traditional roller shutter housing. The curved aluminium inner profile deflects the incoming air upwards into the room.

THE IDEAL SOLUTION FOR RENOVATION

The Transivent, which can be easily integrated in roller shutters, has been developed for situations in which initially no ventilation solution has been foreseen, though in which ventilation is needed.

THERMALLY BROKEN

No cold air transfer from outside to inside.

I-FLUX®

Thanks to its self-regulating flap, the Transivent ensures the supply of fresh and healthy air without draughts. Moreover, the interior profile deflects the incoming air upwards, causing an optimal spread of fresh air in the room.

INSECT MESH

The perforated inside profile acts as an insect mesh.

TECHNICAL CHARACTERISTICS

Airflow	
Equivalent area	13748 mm ² /m
Q at 1 Pa	10,8 l/s/m
Q at 1 Pa	38,9 m ³ /h/m
Q at 2 Pa	15,2 l/s/m
Q at 10 Pa	20,1 l/s/m
Q at 20 Pa	19,9 l/s/m
Comfort	
Sound reduction $D_{n,e,w}$ [C;C _{tr}]	
In open position	28 [-1;-2] dB
In closed position	44 [-1;-2] dB
Technical characteristics	
Controllable internal flap	5 stepped positions
Control options internal flap	Manual, cord, rod, motor
U value	3,0 W/m ² K
Air leakage at 50 Pa	<15% [in closed position]
Watertightness in closed position, up to	650 Pa
Watertightness in open position, up to	150 Pa
Dimensions	
Installation height	91 mm
Fitted height	48 mm
Slot height	50 mm
Depth	60 mm
Max. length	2200 mm [1500 mm for cord control]

TECHNICAL DRAWINGS

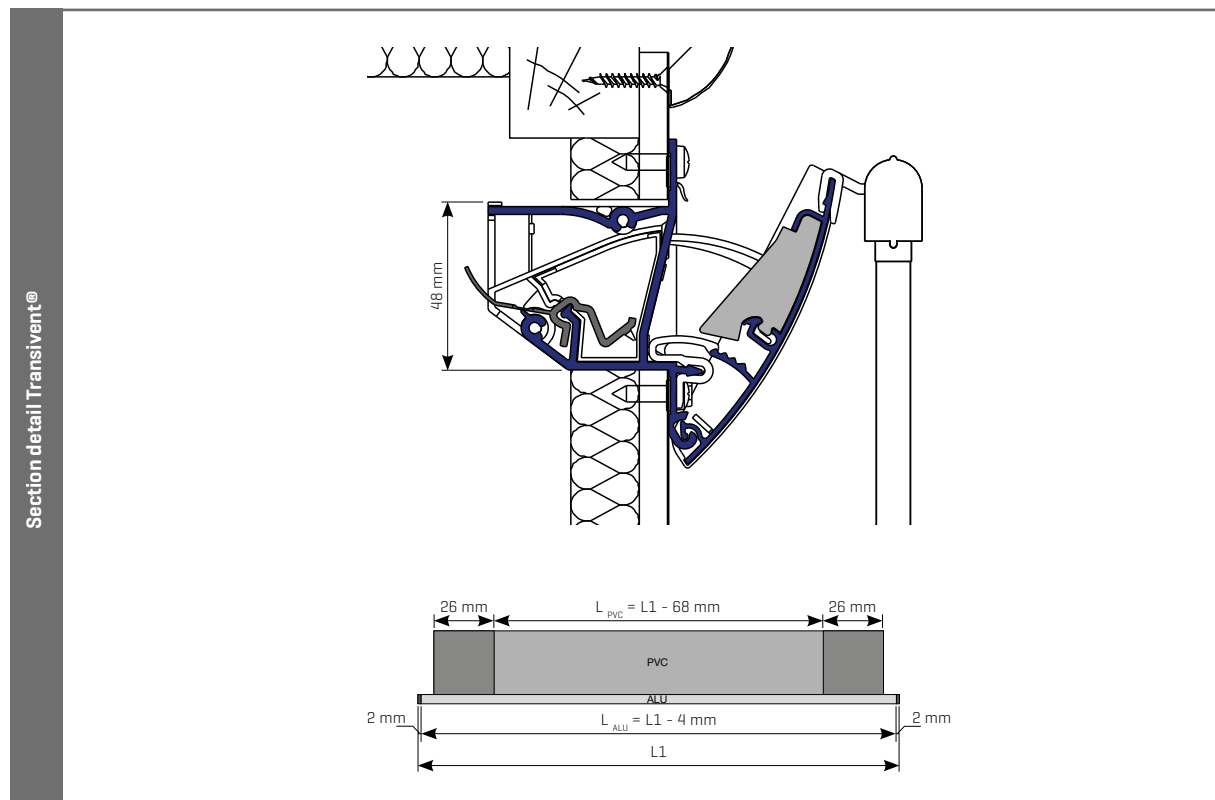

SLIDING VENTS



TH100



58

THL100V



THL100



THL100 – THL100V

Sliding vent

GLAZED-IN



AT TRANSOM

THERMALLY
BROKEN



INTRODUCTION

The THL100 is a thermally broken louvred ventilator, made to measure, installed in a vertical (THL100V) or horizontal (THL100) position.

The THL100V creates a natural air circulation: incoming fresh air at the bottom and outgoing humid warm air at the top of the ventilator.

GLAZED-IN INSTALLATION OR INSTALLATION AT TRANSOM

THL100 or THL100V for glazed-in installation (glass thickness 15, 20, 24, 28 mm)

THL100-TR or THL100V-TR for installation at transom (glass thickness 20, 24, 28 mm)

Not suitable for installation in coastal environments or near the beach.

THERMALLY BROKEN

No cold air transfer from outside to inside.

LOUVRES AT THE OUTSIDE, A SLIDER AT THE INSIDE

INSECT MESH

The perforated inside profile acts as an insect mesh.

EASY AND EFFICIENT

TECHNICAL CHARACTERISTICS

	THL100	THL100V
Airflow		
Equivalent area	16759 mm ² /m	12770 mm ² /m
Q at 1 Pa	13,2 l/s/m	10,0 l/s/m
Q at 1 Pa	47,4 m ³ /h/m	36,1 m ³ /h/m
Q at 2 Pa	18,7 l/s/m	14,2 l/s/m
Q at 10 Pa	41,6 l/s/m	32,1 l/s/m
Q at 20 Pa	58,9 l/s/m	45,5 l/s/m
Comfort		
Sound reduction $D_{n,e,w}$ [C;C _v]		
In open position	22 [0;-0] dB	
In closed position	42 [-1;-2] dB	
Technical characteristics		
Controllable internal flap	Continuous adjustment	
Control options internal flap	Manual, cord, rod, chain, motor	
U value	3,9 W/m ² K	
Air leakage at 50 Pa	-	
Watertightness in closed position, up to	400 Pa	-
Watertightness in open position, up to	-	
Dimensions		
Glass reduction	129 mm	
Height	144 mm	
Glass thickness	20, 24 or 28 mm	
Max. length	3500 mm	

TECHNICAL DRAWINGS

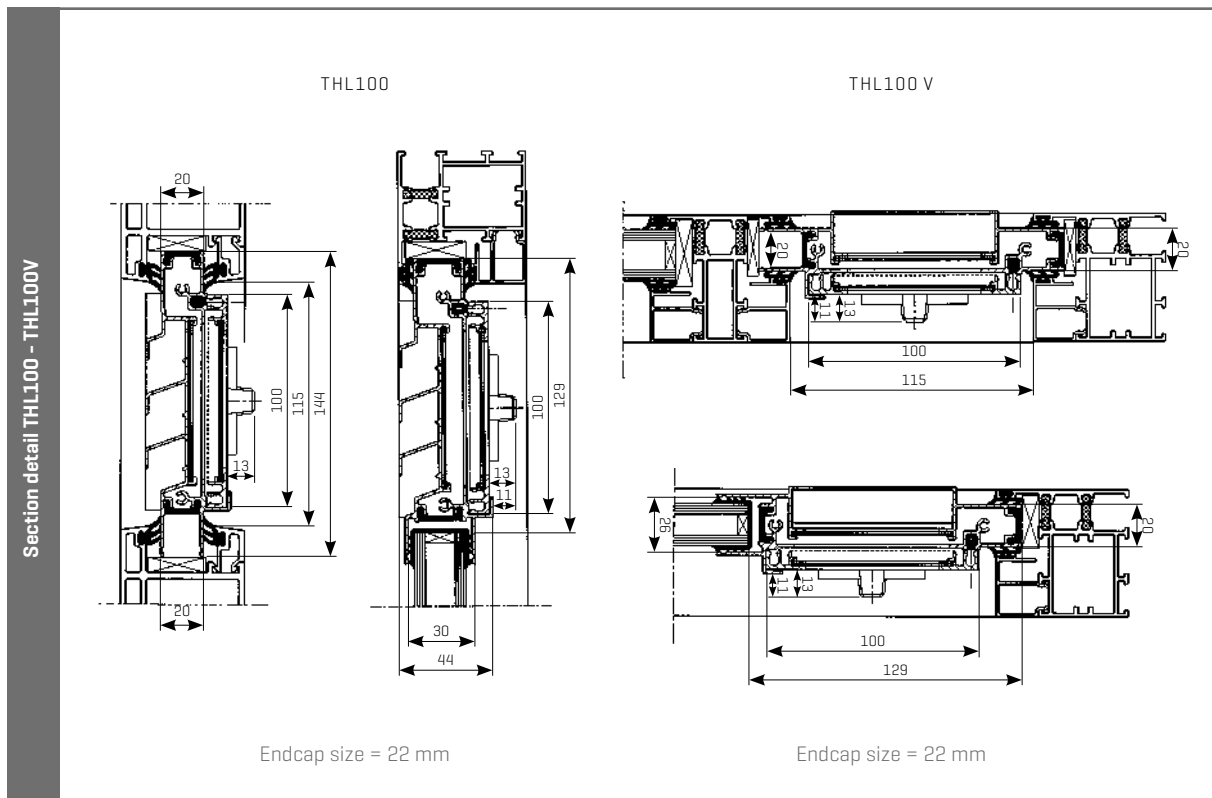

T100 – T130 – T150

Horizontal sliding vents in two parts for installation at transom

AT TRANSOM



INTRODUCTION

The T100, T130 en T150 are aluminium sliding vents without thermal break, to be installed at transom. These types are composed of two unattached parts; the outer part is a decorative louvre with inclined blades to ensure rain protection, the inside part is an aluminium slider that can be adjusted to control the airflow.

INSTALLATION AT TRANSOM

The T100, T130 en T150 can be installed at transom.

Not suitable for installation in coastal environments or near the beach.

INSECT MESH

The perforated inside profile acts as an insect mesh.



TECHNICAL CHARACTERISTICS

	T100	T130	T150
Airflow			
Equivalent area	17326 mm ² /m	24589 mm ² /m	27992 mm ² /m
Q at 1 Pa	13,6 l/s/m	19,3 l/s/m	22,0 l/s/m
Q at 1 Pa	49,0 m ³ /h/m	69,6 m ³ /h/m	79,2 m ³ /h/m
Q at 2 Pa	19,5 l/s/m	27,7 l/s/m	31,9 l/s/m
Q at 10 Pa	43,8 l/s/m	62,1 l/s/m	71,5 l/s/m
Q at 20 Pa	61,9 l/s/m	87,9 l/s/m	101,0 l/s/m
Comfort			
Sound reduction D _{n,e,w} [C;C _v]			
In open position		-	
In closed position		-	
Technical characteristics			
Controllable internal flap	Continuous adjustment		
Control options internal flap	Manual, chain, cord, rod, motor		
U value	-		
Air leakage at 50 Pa	-		
Watertightness in closed position, up to	-		
Watertightness in open position, up to	-		
Dimensions			
Height	100 mm	130 mm	150 mm
Max. length	3500 mm		

TECHNICAL DRAWINGS

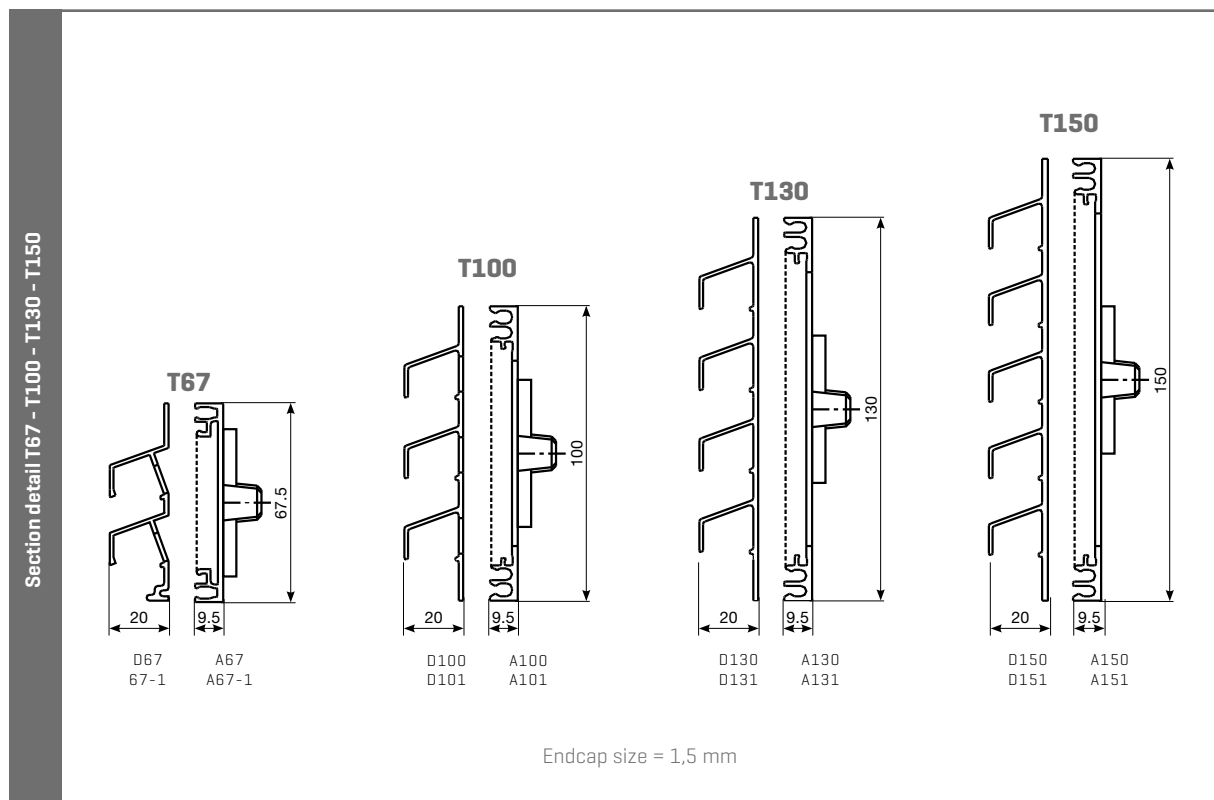

SLOTVENTS



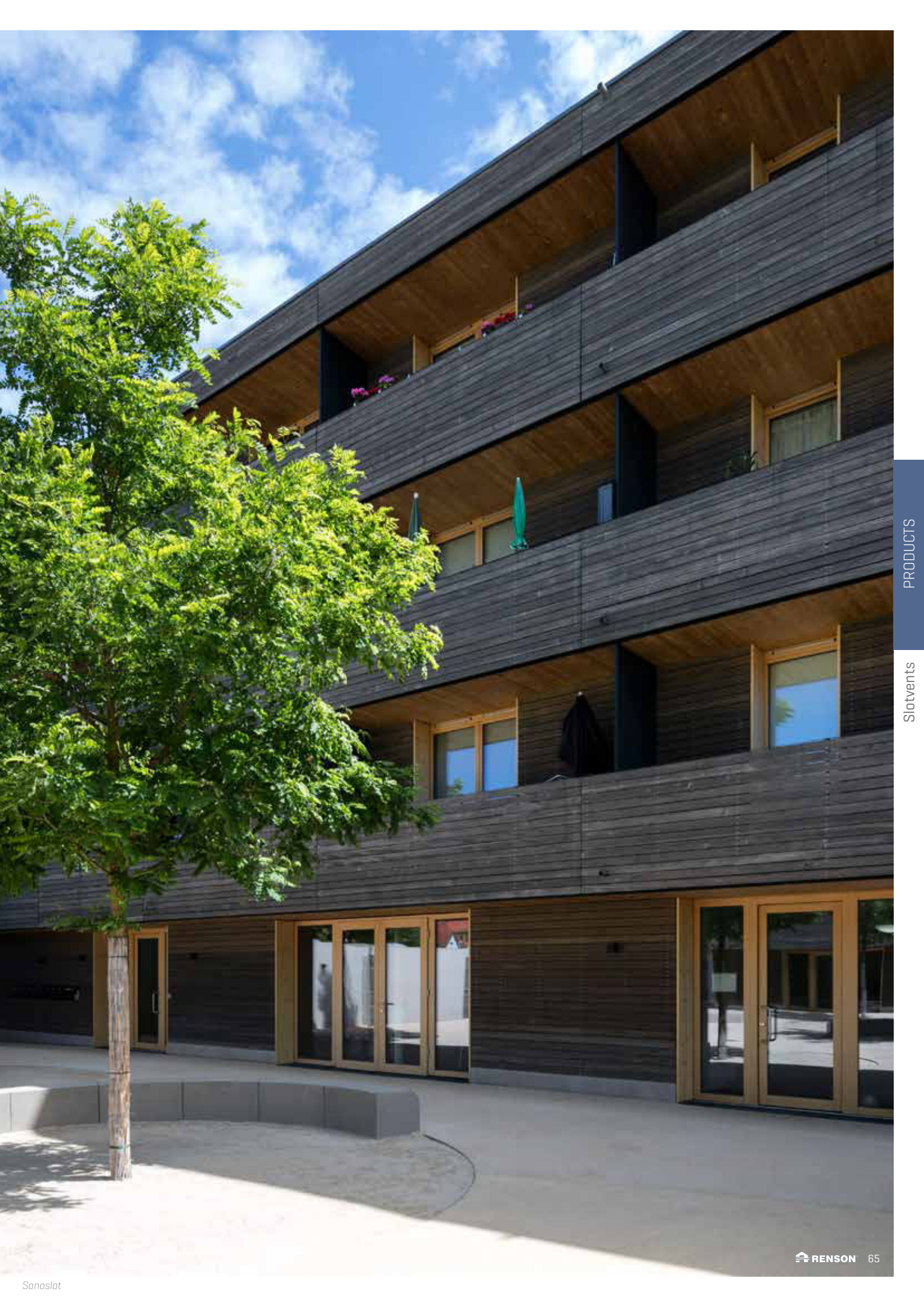



Sonoslot

SLOTVENTS

Introduction



Renson® has developed an extensive range of slotvents. The Renson® slotvents are manufactured in aluminium, this to ensure the highest possible quality and durability. These aluminium slotvents can be powdercoated in any color making a perfect integration possible on wooden, uPVC and aluminium window frames. Renson® proposes some standard lengths for the slotvents but most of the types can be made to measure.

SLOTSIZE OPENINGS

Slotvents are installed on window frames where a slot [10, 12, 16 or 25 mm] is routed through the frame. For long slotvents, enforcement bridges must be taken into account between the gaps, in order to prevent weakening the window frame.

When combining an exterior and an interior slotvent, use the smallest slotsize opening indicated [airflow might be affected].

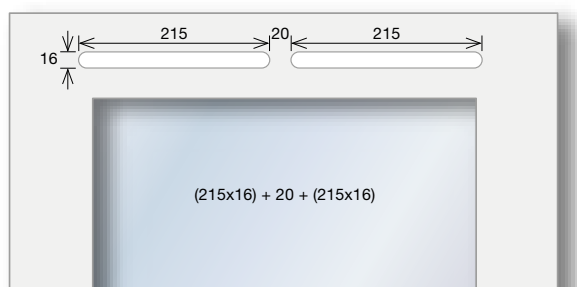
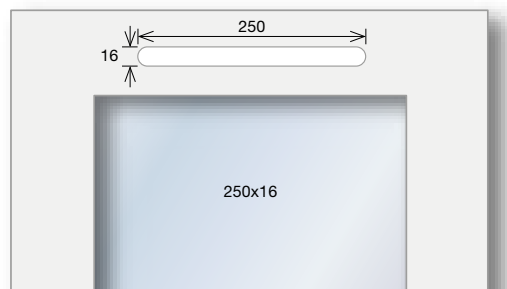

SONOSLOT®

Self-regulating acoustic slotvent kit

SELF-
REGULATING

I-FLUX

SOUND
ABSORBING



INTRODUCTION

The Sonoslot is a self-regulating, sound absorbing slotvent kit consisting of an external slotvent, internal slotvent and a plastic sleeve with integrated sound absorbing baffle in-between. The Sonoslot is available in 4 sizes: 275 mm, 375 mm, 475 mm and 700 mm.

The aluminium external slotvent is self-regulating. This keeps the airflow fairly uniform in strong winds and prevents draughts. Moreover, the external slotvent is perforated and also acts as an insect mesh screen. The noise-damping baffle, made of sound absorbing foam, is standard 70 mm thick and the plastic sleeve is standard 90 mm thick, but both can be easily adapted to suit different window frame depths. The small, narrow and discrete aluminium internal slotvent is manually adjustable and deflects the airflow upwards to prevent direct draughts. Optionally, the Sonoslot can also be installed in permanently open position, by clicking a special clip in the interior slotvent.

The Sonoslot is also available with permanently open clips.

I-FLUX®

Thanks to the self-regulating flap in its exterior slotvent, the Sonoslot ensures the supply of fresh and healthy air without draughts. Moreover, the interior profile deflects the incoming air upwards, causing an optimal spread of fresh air in the room.

SOUND ABSORBING

Sonoslot: up to 38 [0;0] dB in open position

INSECT MESH

The perforated inside profile acts as an insect mesh.

TECHNICAL CHARACTERISTICS

	Sonoslot® 275 mm	Sonoslot® 375 mm	Sonoslot® 475 mm	Sonoslot® 700 mm
Airflow				
Equivalent area	1273 mm ²	1607 mm ²	2121 mm ²	3181 mm ²
Q at 1 Pa	1,0 l/s	1,3 l/s	1,7 l/s	2,5 l/s
Q at 1 Pa	3,6 m ³ /h	4,5 m ³ /h	6,0 m ³ /h	9,0 m ³ /h
Q at 2 Pa	1,4 l/s	1,7 l/s	2,3 l/s	3,4 l/s
Q at 10 Pa	3,2 l/s	4,0 l/s	5,3 l/s	8,0 l/s
Q at 20 Pa	3,3 l/s	4,2 l/s	5,6 l/s	8,4 l/s
Comfort				
Sound reduction D _{n,w} [C;C _{tr}]				
In open position	38 [0;0] dB	37 [0;0] dB	36 [0;0] dB	34 [0;0] dB
In closed position			-	
Technical characteristics				
Controllable internal flap	Continuous adjustment			
Control options internal flap	Manual			
U value	1,4 W/m ² .K			
Air leakage at 50 Pa	< 15 % in closed position			
Watertightness in closed position, up to	-			
Watertightness in open position, up to	-			
Dimensions				
Height	35 mm			
Length	275 mm	375 mm	475 mm	700 mm
Slotsize opening	(105,5 x 16) + 24 + (105,5 x 16)	(105,5 x 16) + 14,3 + (105,5 x 16) + 14,3 + (105,5 x 16)	(105,5 x 16) + 7,5 + (105,5 x 16) + 7,5 + (105,5 x 16) + 7,5 + (105,5 x 16)	(105,5 x 16) + 7,5 + (105,5 x 16) + 7,5 + (105,5 x 16) + 7,5 + (105,5 x 16) + 7,5 + (105,5 x 16) + 7,5 + (105,5 x 16)
Length acoustic foam	2 x 103 mm	3 x 103 mm	4 x 103 mm	6 x 103 mm
Depth acoustic foam	70 mm			
Depth plastic sleeve	90 mm			

TECHNICAL DRAWINGS

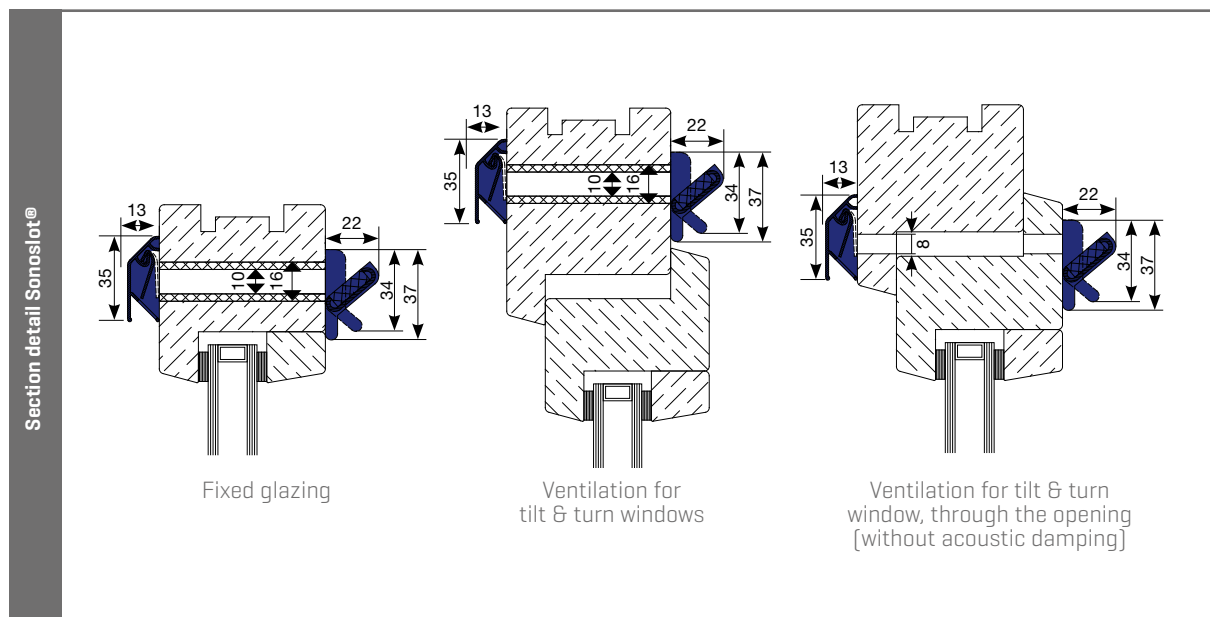

SONOSLOT® MAX

Self-regulating slotvent kit with high acoustic damping

HIGH ACOUSTIC
DAMPING

SELF-
REGULATING

I-FLUX



INTRODUCTION

Sonoslot Max is a self-regulating slotvent kit offering a higher sound absorption than the Sonoslot, existing of an external slotvent, an internal slotvent and a plastic sleeve with integrated sound absorbing baffle in-between.

The aluminium external slotvent is self-regulating, which keeps the airflow fairly uniform in strong winds and prevents draughts. Moreover, the external slotvent is perforated and also acts as an insect mesh screen.

The internal slotvent of the Sonoslot Max is permanently open and includes extra acoustic damping. The noise-damping baffle is standard 70 mm thick and the plastic sleeve is standard 90 mm thick, but both can easily be adapted to suit different window frame depths.

This slotvent combination suits for all window depths. It can be used for both new-built and renovation projects.

SELF-REGULATING

Thanks to the self-regulating flap in its exterior slotvent, the Sonoslot Max ensures the supply of fresh and healthy air without draughts.

SOUND ABSORBING

Up to 40 [-1;-2] dB in open position.

INSECT MESH

The perforated inside profile acts as an insect mesh.

TECHNICAL CHARACTERISTICS

	Without acoustic foam	With acoustic foam
Airflow		
Equivalent area	2298 mm ²	1555 mm ²
Q at 1 Pa	1,8 l/s	1,2 l/s
Q at 1 Pa	6,5 m ³ /h	4,4 m ³ /h
Q at 2 Pa	2,7 l/s	1,9 l/s
Q at 10 Pa	6,8 l/s	5,1 l/s
Q at 20 Pa	6,9 l/s	7,6 l/s
Comfort		
Sound reduction $D_{n,e,w}$ [C;C _{tr}]		
In open position	38 [-1;-2] dB	40 [-1;-2] dB
In closed position		-
Technical characteristics		
Controllable internal flap		no
Control options internal flap		n.a.
U value		-
Air leakage at 50 Pa		-
Watertightness in closed position, up to		-
Watertightness in open position, up to		-
Dimensions		
Height	35 mm [exterior part] / 45 mm [interior part]	
Length	700 mm	
Ausschnittmaß	[105,5 x 16] + 7,5 + [105,5 x 16] + 7,5 + [105,5 x 16] + 7,5 + [105,5 x 16] + 7,5 + [105,5 x 16]	
Length acoustic foam	n.a.	6 x 103 mm
Depth acoustic foam	n.a.	70 mm
Depth plastic sleeve	90 mm	

TECHNICAL DRAWINGS

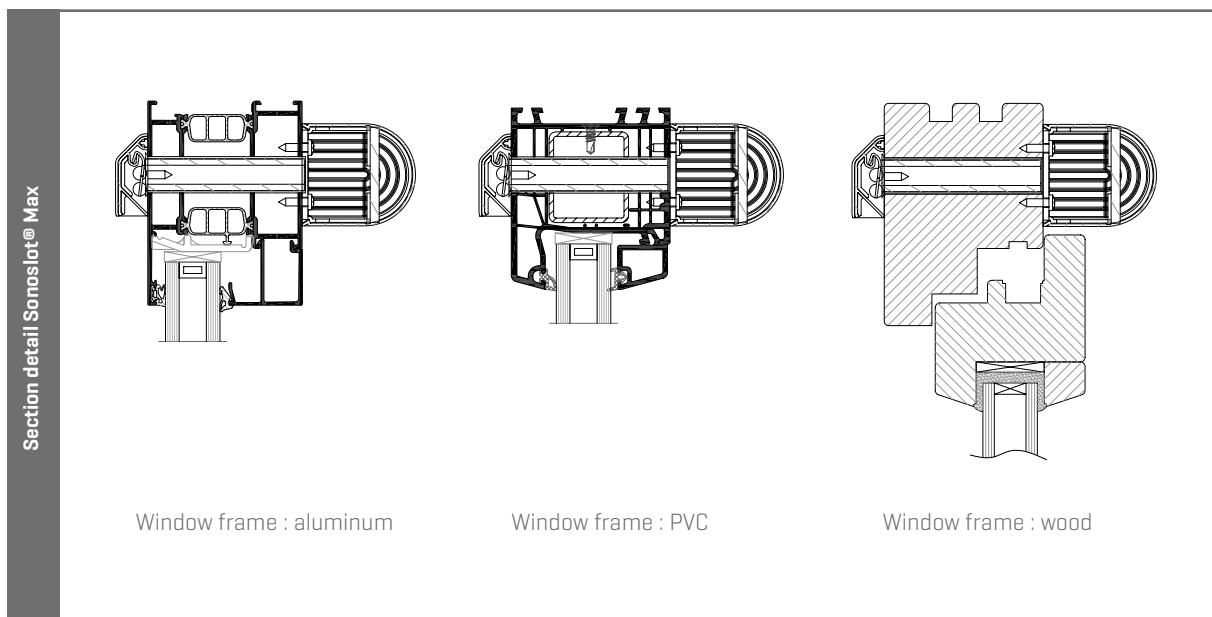

PYRAMID

Smallest vent on the market that provides 5000 mm² EA airflow

HIGH AIRFLOW

COANDA EFFECT

INSECT MESH



INTRODUCTION

The Pyramid is a non-self-regulating compact slotvent kit. It is the smallest vent on the market responding to the ventilation regulation Part F [England & Wales] providing an Equivalent Area of 5000 mm². The Pyramid ventilator is surface mounted on uPVC, Timber and Aluminium windows and is compatible with slot heights from 13 up to 16 mm.

The external canopy offers excellent weather protection and incorporates a stainless steel fly screen. The vent is easy to open and to control.

The internal slotvent deflects, in open position, the incoming air upwards for air optimal spread of fresh air in the room. The Pyramid is available in 2 types: 2500 EA or 5000 EA [other lengths on demand]

The Pyramid Vent is available in black, grey or white. Other colours on demand.

COANDA EFFECT

The interior profile deflects the incoming air upwards, causing an optimal spread of fresh air in the room.

TECHNICAL CHARACTERISTICS

	2500	5000
Airflow		
Equivalent area	2723	5229
Q at 1 Pa	2,1 l/s	4,2 l/s
Q at 1 Pa	7,6 m ³ /h	15,1 m ³ /h
Q at 2 Pa	3,1 l/s	6,0 l/s
Q at 10 Pa	7,0 l/s	13,6 l/s
Q at 20 Pa	10,1 l/s	19,4 l/s
Comfort		
Sound reduction $D_{n,e,w}$ [C;C _v]		
in open position	36 [0; 0] dB	33 [-1; 0] dB
in closed position	51 [-2; -3] dB	51 [-1; -3] dB
Technical characteristics		
Controllable internal flap	Continuous adjustment	
Control options internal flap	Manual	
U value	-	
Air leakage at 50 Pa	-	
Watertightness in closed position, up to	-	
Watertightness in open position, up to	-	
Dimensions		
Height	25 mm	
Length*	248 mm	410 mm
Slotsize opening	192 x 13	[172 x 13 to 16] + 10 + [172 x 13 to 16]

* other lengths on demand

TECHNICAL DRAWINGS

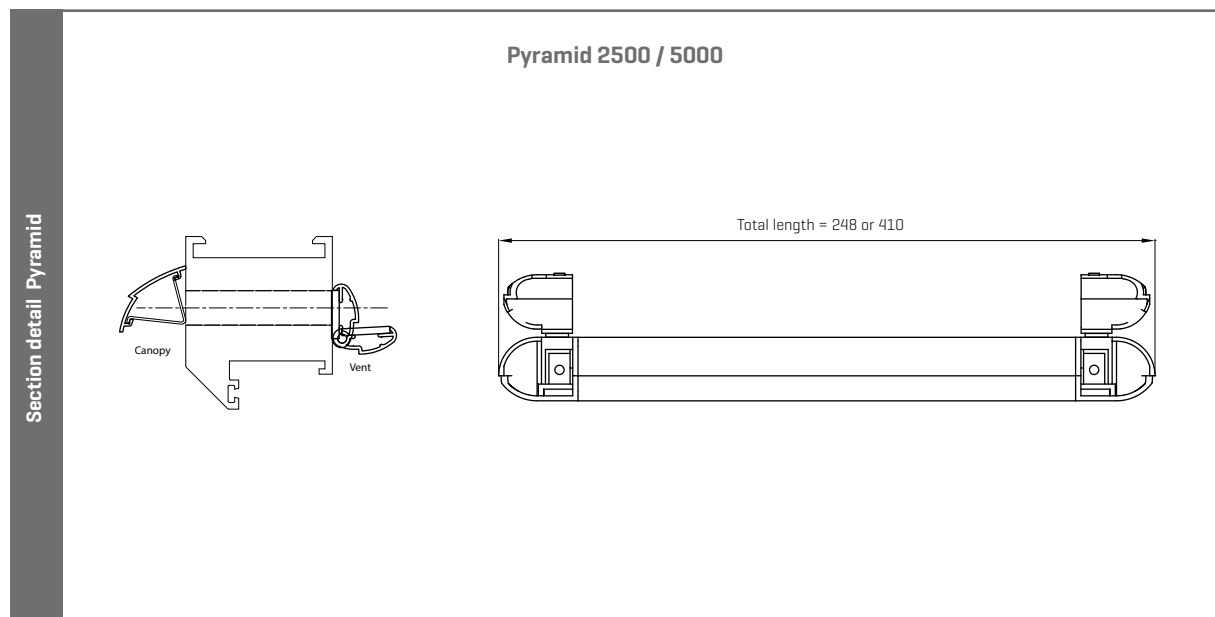

PYRACOUST

Smallest acoustic window vent providing 2500 mm² or 5000 mm² EA

SOUND
ABSORBING

COANDA EFFECT

INSECT MESH



INTRODUCTION

Based on our Pyramid vent, the PyrAcoust is the smallest acoustic window vent (non-self-regulating) providing 2500 mm² or 5000 mm² Equivalent Area with the best acoustic performances for window ventilators available in the UK: up to 45 dB in open position.

SOUND ABSORBING

The modularity of the acoustic sets provides flexibility for installation and acoustic performance.

Sets comprise of:

- 1 Pyramid (2500 or 5000) + 1 acoustic module (for internal or external installation): providing noise reduction with discreet internal aesthetics
- 1 Pyramid (2500 or 5000) + 2 acoustic modules (for internal and external installation): providing maximum noise reduction

The external canopy offers excellent weather protection and incorporates a stainless steel fly screen. The vent is easy to open and control. The PyrAcoust is designed for use with Timber, uPVC and Aluminium

COANDA EFFECT

The interior profile deflects the incoming air upwards, causing an optimal spread of fresh air in the room.

SLOTVENTS

Interior

478 - Flat grille

Type	Length [mm]	Height [mm]	Slotsize opening [mm]	Airflow			
				1 Pa [l/s]	2 Pa [l/s]	2 Pa [m³/h]	Equivalent Area [mm²]
478/1	275	20	230 x 16	1,9	2,8	9,9	2453
478/2	375	20	330 x 16	2,8	3,9	14,2	3512
478/3	475	20	[205 x 16] + 20 + [205 x 16]	3,7	5,4	19,3	4753
478/4	700	20	[315 x 16] + 25 + [315 x 16]	5,6	8,0	28,8	7119



485 - Hit and miss vent

Type	Length [mm]	Height [mm]	Slotsize opening [mm]	Airflow			
				1 Pa [l/s]	2 Pa [l/s]	2 Pa [m³/h]	Equivalent Area [mm²]
485/1	275	22	230 x 16	1,2	1,8	6,4	1551
485/2	375	22	330 x 16	1,9	2,7	9,9	2438
485/3	475	22	[210 x 16] + 20 + [200 x 16]	2,5	3,6	13,1	3214
485/4	700	22	[310 x 16] + 20 + [325 x 16]	4,1	6,0	21,6	5203

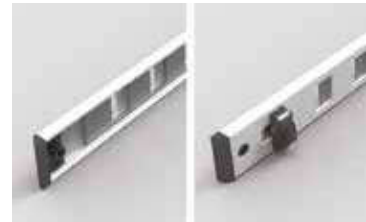

488 - Patio grille

Type	Length [mm]	Height [mm]	Slotsize opening [mm]	Airflow			
				1 Pa [l/s]	2 Pa [l/s]	2 Pa [m³/h]	Equivalent Area [mm²]
488/1	275	30	250 x 25	3,1	4,3	15,5	3899
488/2	375	30	[165 x 25] + 20 + [165 x 25]	4,3	5,9	21,4	5423
488/3	475	30	[215 x 25] + 20 + [215 x 25]	4,5	6,8	24,6	5787
488/4	700	30	[325 x 25] + 25 + [325 x 25]	8,5	12,1	43,5	10839



489 - Bar grille

Type	Length [mm]	Height [mm]	Slotsize opening [mm]	Airflow			
				1 Pa [l/s]	2 Pa [l/s]	2 Pa [m³/h]	Equivalent Area [mm²]
489/1	275	24	237 x 18	1,7	2,5	8,9	2202
489/2	375	24	337 x 18	2,2	3,2	11,7	2822
489/3	475	24	[210 x 18] + 17 + [210 x 18]	3,0	4,3	15,3	3807
489/4	700	24	[320 x 18] + 22 + [320 x 18]	5,1	7,2	25,8	6477

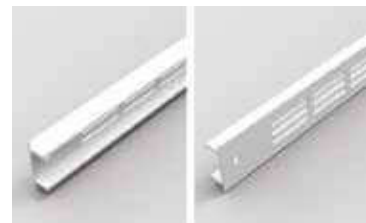

787AK - Tipvent

Type	Length [mm]	Height [mm]	Slotsize opening [mm]	Airflow			
				1 Pa [l/s]	2 Pa [l/s]	2 Pa [m³/h]	Equivalent Area [mm²]
787AK/1	275	28	245 x 16	3,2	4,6	16,7	4127
787AK/2	375	28	345 x 16	4,0	5,7	20,5	5108
787AK/3	475	28	[215 x 16] + 20 + [215 x 16]	5,1	7,3	26,3	6525
787AK/4	700	28	[325 x 16] + 25 + [325 x 16]	9,0	12,9	46,5	11455



SLOTVENTS

Exterior

471 - Self regulating canopy

Type	Length [mm]	Height [mm]	Slotsize opening [mm]	Airflow			
				1 Pa [l/s]	2 Pa [l/s]	2 Pa [m³/h]	Equivalent Area [mm²]
471/1	275	35	250 x 25	1,4	2,0	7,3	1785
471/2	375	35	350 x 25	2,0	3,0	10,8	2527
471/3	475	35	[215 x 25] + 20 + [215 x 25]	2,3	3,7	13,2	2951
471/4	700	35	[325 x 25] + 20 + [325 x 25]	4,0	6,0	21,5	5055



TECHNICAL DRAWINGS

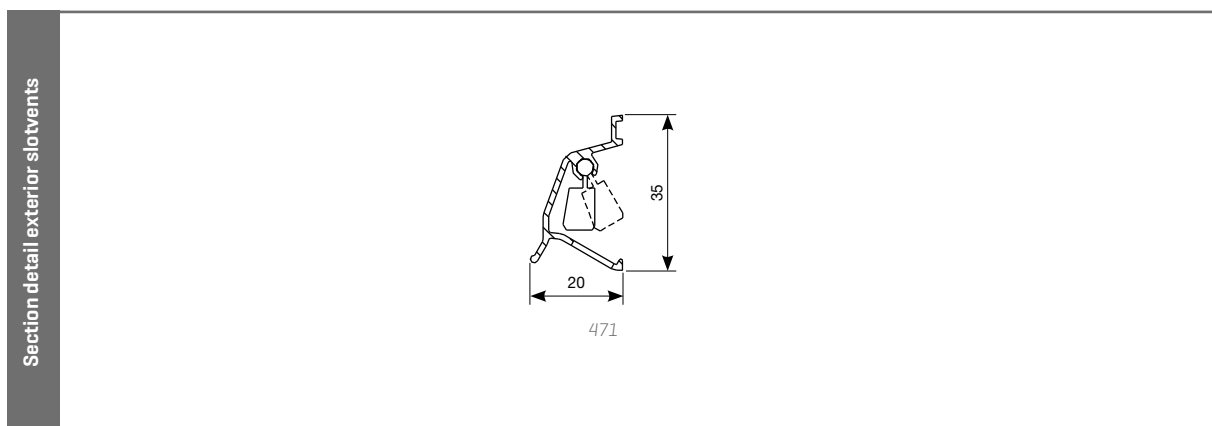
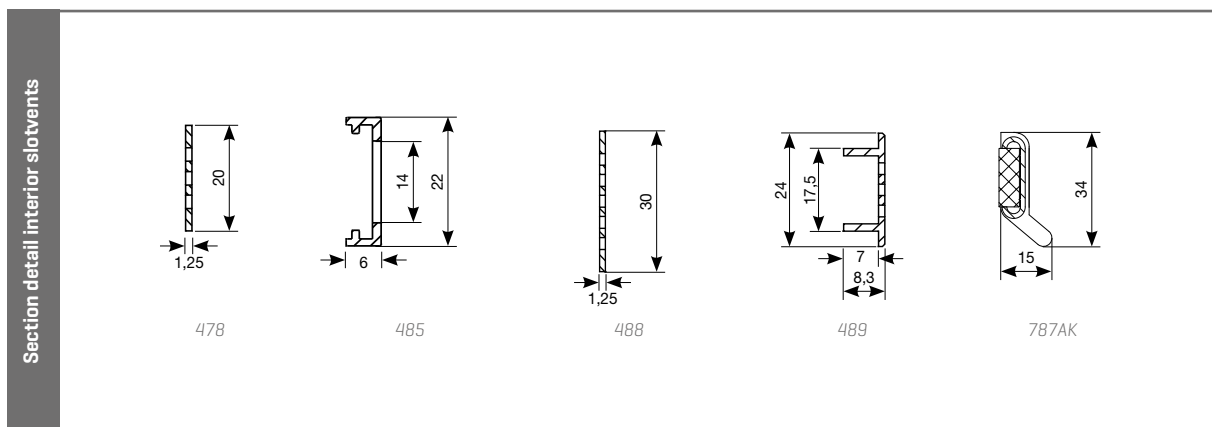

COMBINED VENTILATION AND SUN SHADING OVERFRAME





FIXVENT® MONO AK^{EVO}

The perfect combination of ventilation, windproof sun protection and insect resistance

OVERFRAME

SELF-REGULATING I-FLUX

SOUND ABSORBING

VENTILATION + WINDPROOF SUNPROTECTION



INTRODUCTION

Renson® brings with Fixvent Mono AK^{EVO} an aesthetical and comfortable solution that combines ventilation, windproof sun protection and insect resistance. This product, which is installed as a monobloc, can perfectly be used in both new-built and renovation. Fixvent Mono AK^{EVO} can, thanks to the same 'look & feel', be perfectly combined with Fixscreen Mono AK^{EVO}, combining windproof sun protection and insect resistance in one product.

INSTALLATION ON TOP OF THE WINDOW FRAME

Fixvent Mono AK^{EVO} is installed on top of the window frame, with fully finished box. This product can easily be installed on all window profiles [alu, PVC, wood] from 50 up to 215 mm.

THERMALLY BROKEN

No cold air transfer from outside to inside.

I-FLUX®

Thanks to its self-regulating flap, the Fixvent Mono AK^{EVO} ensures the supply of fresh and healthy air without draughts. Moreover, the interior profile deflects the incoming air upwards, causing an optimal spread of fresh air in the room.

SOUND ABSORBING

3 levels of sound reduction in open position:

- Fixvent Mono AK^{EVO}: up to 40 [-1; -4] dB
- Fixvent Mono AK^{EVO} Ultra: up to 45 [-1; -5] dB
- Fixvent Mono AK^{EVO} Extreme: up to 48 [-2; -5] dB

CONNECT&GO AND CLICK&SAFE

Thanks to the patented Connect&Go and Click&Safe technology, an easy [dis]mounting of the screen tube can be guaranteed.

WINDTIGHT UP TO 130 KM/H

The Fixscreen technology provides a tight and windproof screen up to 130 km/h [screen placed in closed position before a window construction].

SMOOTH AND SILENT

Thanks to the Smooth technology, which provides the zipper guides of a patented wear-resistant layer, the screen goes up and down smoothly and silently.

INSECT MESH

The perforated inside profile acts as an insect mesh.

INTEGRATION IN SYSTEM C+®

This window vent guarantees an optimal indoor air quality in combination with Healthbox 3.0.

TECHNICAL CHARACTERISTICS

	Small	Medium	Large	X-Large	XX-Large
Airflow					
Equivalent Area					
Fixivent® Mono AK ^{EVO}			18324 mm ² /m		
Fixivent® Mono AK ^{EVO} ULTRA			4836 mm ² /m		
Fixivent® Mono AK ^{EVO} EXTREME			2800 mm ² /m		
Q at 1 Pa					
Fixivent® Mono AK ^{EVO}			12,8 l/s/m		
Fixivent® Mono AK ^{EVO} ULTRA			3,7 l/s/m		
Fixivent® Mono AK ^{EVO} EXTREME			2,1 l/s/m		
Comfort					
Sound reduction $D_{n,w}$ [C;C _{tr}] in open position [screen up]					
Fixivent® Mono AK ^{EVO}	33 [0;-2] dB	35 [0;-3] dB	36 [-1;-4] dB	37 [-1;-4] dB	40 [-1;-4] dB
Fixivent® Mono AK ^{EVO} ULTRA	n.a.	38 [0;-2] dB	40 [-1;-4] dB	43 [-1;-4] dB	45 [-1;-5] dB
Fixivent® Mono AK ^{EVO} EXTREME	n.a.	43 [0;-3] dB	43 [0;-3] dB	46 [-1;-4] dB	48 [-2;-5] dB
Technical characteristics					
Self-regulating at 2Pa			Yes		
Thermally broken			Yes		
U-value [W/m ² K]					
Fixivent® Mono AK ^{EVO}	1,47 W/m ² K	0,98 W/m ² K	0,80 W/m ² K	0,77 W/m ² K	0,72 W/m ² K
Fixivent® Mono AK ^{EVO} ULTRA	n.a.	0,70 W/m ² K	0,55 W/m ² K	0,46 W/m ² K	0,41 W/m ² K
Fixivent® Mono AK ^{EVO} EXTREME	n.a.	0,62 W/m ² K	0,47 W/m ² K	0,38 W/m ² K	0,32 W/m ² K
Airflow leakage in closed position			< 15% at 50 Pa		
Insect mesh			Yes		
Control					
Screen			motor control		
Ventilation flap			manual, rod, motor		
Dimensions					
Box					
Box height [mm]			132 mm		
Box width [mm]	167 mm	197 mm	227 mm	257 mm	287 mm
Compatible window depths [mm]	50-94 mm	95-124 mm	125-154 mm	155-184 mm	185-215 mm
Screen: max. WxH [mm]+max. surface					
Single [1 screen - 1 control]			4000 x 3000 [12 m ²]		
Coupled [2 parts - 2 motors]			6000 x 3000 mm [18 m ²]		
Bottom bar [DxH] [mm]			30 x 57 mm		

FIXVENT® MONO AK^{EVO}

The perfect combination of ventilation, windproof sun protection and insect resistance

VENTILATION
+ WINDPROOF
SUNPROTECTION

SELF-
REGULATING
I-FLUX

SOUND
ABSORBING

OVERFRAME

TECHNICAL DRAWINGS

Section detail Fixvent Mono AK^{EVO}

Small
[for window depths 50-94 mm]

Finished height

CF1 CF2

Medium
[for window depths 95-124 mm]

Finished height

CF1 CF2

Large
[for window depths 125-154 mm]

Finished height

CF1 CF2

X-Large
[for window depths 155-184 mm]

Finished height

CF1 CF2

XX-Large
[for window depths 185-215 mm]

Finished height

CF1 CF2

Optional: deeper box size compared to the standard window frame group (e.g. for a better U-value or acoustic comfort)

Example 1: Type 'Medium' on smaller window

Finished height

CF1 CF2

[+ extra extension profile 30 mm]

Example 2: Type 'Large' on smaller window

Finished height

CF1 CF2

[+ extra extension profile 60 mm]

➔ Direction demounting fabric roller

Box type	Dimension optional extension profile
Small	no extension profile
Medium	extension profile 30 mm
Large	extension profile 60 mm
X-Large	extension profile 90 mm
XX-Large	extension profile 120 mm

Direction demounting fabric roller defines the position of the motor left or right



FIXVENT® MONO UT^{EVO}

The perfect combination of ventilation, windproof sun protection and insect resistance for utility

OVERFRAME

SELF-REGULATING I-FLUX

SOUND ABSORBING

VENTILATION + WINDPROOF SUNPROTECTION



INTRODUCTION

Fixvent Mono UT^{EVO} combines, just as Fixvent Mono AK^{EVO} does, ventilation, windproof sun protection and insect-resistance in one and the same product. This UT-version has specifically been developed for utility, which makes this the perfect solution for e.g. schools or offices in which large amounts of airflow are required.

UTILITY BUILDINGS

INSTALLATION ON TOP OF THE WINDOW FRAME

Fixvent Mono UT^{EVO} is installed on top of the window frame, with fully finished box. This product can easily be installed on all window profiles [alu, PVC, wood] from 50 up to 215 mm.

I-FLUX®

Thanks to its self-regulating flap, the Invisivent^{EVO} UT ensures the supply of fresh and healthy air without draughts. The self-regulating flap only starts working at a wind pressure of 10 Pa [instead of 2 Pa].

SOUND ABSORBING

2 levels of sound reduction in open position:

- Fixvent Mono UT^{EVO}: up to 40 [-1; -4] dB
- Fixvent Mono UT^{EVO} Ultra: up to 45 [-1; -5] dB

CONNECT&GO AND CLICK&SAFE

Thanks to the patented Connect&Go and Click&Safe technology, an easy [dis]mounting of the screen tube can be guaranteed.

WINDTIGHT UP TO 130 KM/H

The Fixscreen technology provides a tight and windproof screen up to 130 km/h [screen placed in closed position before a window construction].

SMOOTH AND SILENT

Thanks to the Smooth technology, which provides the zipper guides of a patented wear-resistant layer, the screen goes up and down smoothly and silently.

INSECT MESH

The perforated inside profile acts as an insect mesh.

INTEGRATION IN SYSTEM C+®

This window vent guarantees an optimal indoor air quality in combination with Healthbox 3.0.

TECHNICAL CHARACTERISTICS

	Small	Medium	Large	X-Large	XX-Large
Airflow					
Equivalent Area					
Fixivent® Mono UT ^{EVO}	19724 mm ² /m				
Fixivent® Mono UT ^{EVO} ULTRA	4836 mm ² /m				
Q at 1 Pa					
Fixivent® Mono UT ^{EVO}	15,5 l/s/m				
Fixivent® Mono UT ^{EVO} ULTRA	3,7 l/s/m				
Comfort					
Sound reduction $D_{n,e,w}$ [C;C _{tr}] in open position [screen up]					
Fixivent® Mono UT ^{EVO}	33 [0;-2] dB	35 [0;-3] dB	36 [-1;-4] dB	37 [-1;-4] dB	40 [-1;-4] dB
Fixivent® Mono UT ^{EVO} ULTRA	n.a.	38 [0;-2] dB	40 [-1;-4] dB	43 [-1;-4] dB	45 [-1;-5] dB
Technical characteristics					
Self-regulating at 10 Pa	Yes				
Thermally broken	Yes				
U-value [W/m ² K]					
Fixivent® Mono UT ^{EVO}	1,47 W/m ² K	0,98 W/m ² K	0,80 W/m ² K	0,77 W/m ² K	0,72 W/m ² K
Fixivent® Mono UT ^{EVO} ULTRA	n.a.	0,70 W/m ² K	0,55 W/m ² K	0,46 W/m ² K	0,41 W/m ² K
Airflow leakage in closed position	< 15% at 50 Pa				
Insect mesh	Yes				
Control					
Screen	motor control				
Ventilation flap	manual, rod, motor				
Dimensions					
Box					
Box height [mm]	132 mm				
Box width [mm]	167 mm	197 mm	227 mm	257 mm	287 mm
Compatible window depths [mm]	50-94 mm	95-124 mm	125-154 mm	155-184 mm	185-215 mm
Screen: max. WxH [mm]+max. surface					
Single [1 screen - 1 control]	4000 x 3000 [12 m ²]				
Coupled [2 parts - 2 motors]	6000 x 3000 mm [18 m ²]				
Bottom bar [DxH] [mm]	30 x 57 mm				

FIXVENT® MONO UT^{EVO}

The perfect combination of ventilation, windproof sun protection and insect resistance for utility

TECHNICAL DRAWINGS

- OVERFRAME
- SELF-REGULATING I-FLUX
- SOUND ABSORBING
- VENTILATION + WINDPROOF SUNPROTECTION

Section detail Fixvent Mono AK^{EVO}

Small
[for window depths 50-94 mm]

Medium
[for window depths 95-124 mm]

Large
[for window depths 125-154 mm]

X-Large
[for window depths 155-184 mm]

XX-Large
[for window depths 185-215 mm]

Optional: deeper box size compared to the standard window frame group (e.g. for a better U-value or acoustic comfort)

Example 1: Type 'Medium' on smaller window

[+ extra extension profile 30 mm]

Example 2: Type 'Large' on smaller window

[+ extra extension profile 60 mm]

Direction demounting fabric roller

Box type	Dimension optional extension profile
Small	no extension profile
Medium	extension profile 30 mm
Large	extension profile 60 mm
X-Large	extension profile 90 mm
XX-Large	extension profile 120 mm

Direction demounting fabric roller defines the position of the motor left or right



EPILOGUE

GLAZING GASKETS

Renson® advises the use of special designed glazing gaskets;

- Nr 019, colour: black, for glass thickness 36 - 40 - 44 mm
- Nr 029, colour: black, for glass thickness 28 - 36 mm
- Nr 034, colour: grey, for glass thickness 20 - 28 mm
- Nr 039, colour: black, for glass thickness 20 - 28 mm

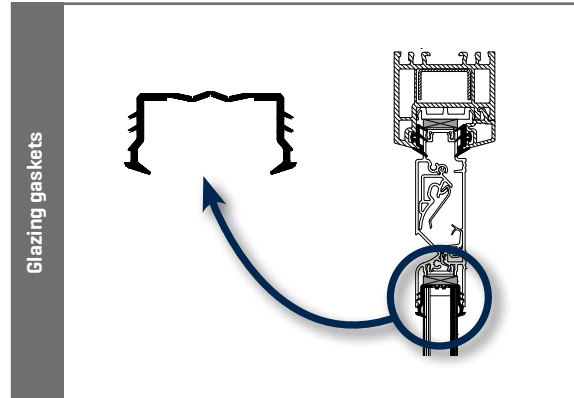

CONTROLS

- Manual: possible through manually opening/closing of the flap (eg. Invisivent EVO range), knob (e.g. THM90EVO), lever (e.g. AR75). Standard lever is 30 mm, but longer levers (40, 50, 60 and 70 mm) are available upon request.

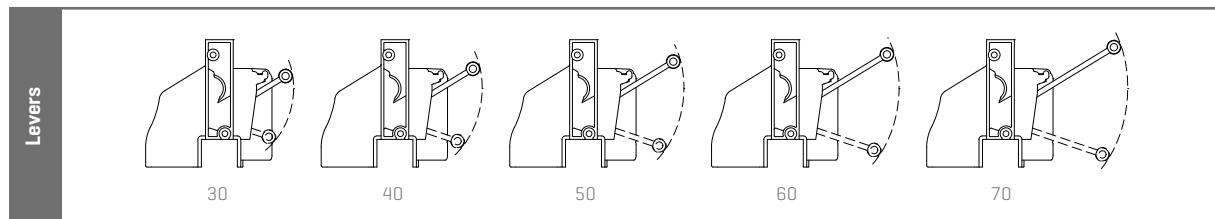

- Cord: standard length for cord control is 1000 mm, other dimensions are available upon request.
- Rod: standard length for rod control is 1000 mm, other dimensions are available upon request. The rod can be powdercoated in any RAL or Syntha Pulvin colour upon request. Also rod control with hook-up, with transmission and with sliding knob are available for certain vents (e.g. THM90EVO).
- Motor: possible by means of an 'On/Off' or a '0-10V' (for home automation) switch. Standard cable length: 3 m (except THL100(V), TL67-100-100PB, T67-100-130-150). The position of the cable exit for a Sonovent with motor control can be top left, top right, bottom left or bottom right.
- Not all control options are possible for all vents.

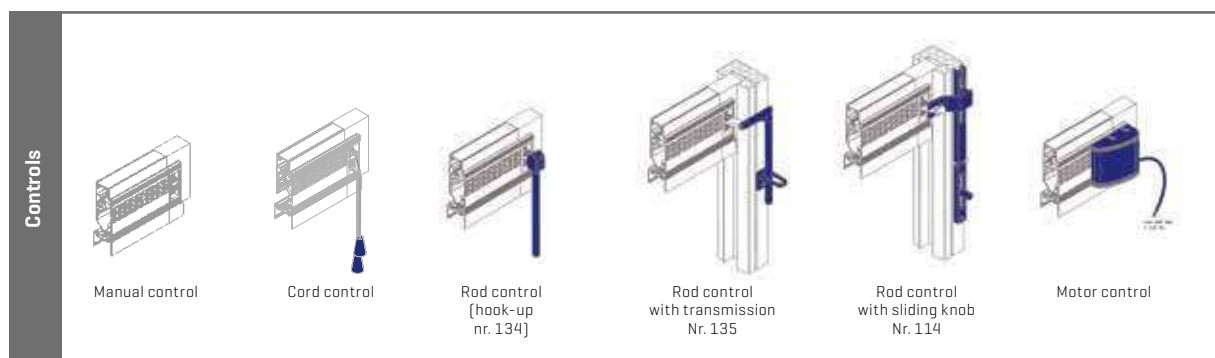

FINISHING

- Material internal and external profile: extruded AlMgSi 0.5 aluminium [according to EN 12020-2 and EN AW-6063]
- Finishing internal and external profile: bronze or satin anodized [E6/EV1-SAA, except for Oxyvent and Sonovent range] or powdercoated in any RAL or Syntha Pulvin colour [dual colour possible]. Pre-treatment is recommended when used in an aggressive [in accordance with the standard Seaside Quality A] or a very aggressive [pre-anodisation] environment like sea-side, chemical industry, ...]
- Thermal bridge: extruded PVC [according to DIN 16941]
- Material end caps: ASA polymer type Luran S [colour-fast, weather- and UV-resistant]
- Colour end caps:
 - Overframe flap ventilators: available in any colour upon request [dual colour possible], dyed in the mass or painted
 - Other flap ventilators: black or white [and for AR75 also 1013, 1015, 7016, 7021, 7030, 7035, 7039, 8019, 9001, 9007], other colours available upon request
 - Sliding vents: black
 - Slot vents: black or white, depending on the type of slotvent

MAINTENANCE

Almost all the Renson® window vents have a removable inner part for ease of maintenance.

Maintenance must be performed at least once a year. Clean the inside using a vacuum cleaner and/or damp cloth. Remove leaves and other dirt from the outside of the window vent. Clean the outside aluminium part with a damp cloth and a non-abrasive cleaner. Rinse the window vent thoroughly with clean water.

EPILOGUE

TRANSOM PROFILES

Two different transom profiles [height 35 mm or 62 mm] are available for the ventilators installed at transom. The transom profiles have been developed for easy and swift fabrication from bar lengths and are also available made to measure. These profiles can be satin anodised or powdercoated in any RAL or Syntha Pulvin colour.

For the THM90^{EVO} Renson® has developed special types which do not require transom profiles; the THM90PB^{EVO} for installation at the bottom of a window and the THM90TR^{EVO} for fully glazed-in installation between profiles [at transom].

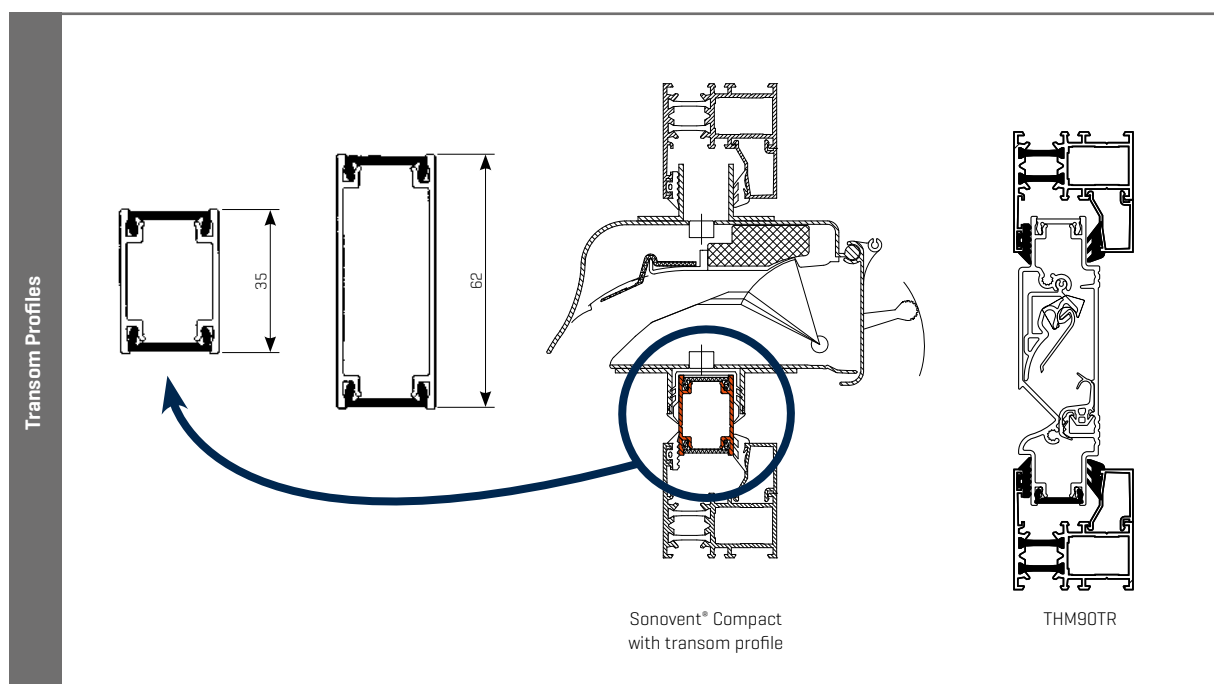

POLLUX®: OPTIONAL FINE DUST AND POLLEN FILTER

If you live in a strongly fine dust-loaded environment (such as near a highway or an industrial area), or if you suffer from hay fever (caused by pollen), the supply of fresh and healthy air can still be guaranteed by installing the Pollux in your Renson® window ventilator.

The Pollux can be installed in these Renson® window vents:

- The Invisivent AIR/COMFORT-range
- AR60 / THK60
- AR75
- Sonovent / Sonovent Compact

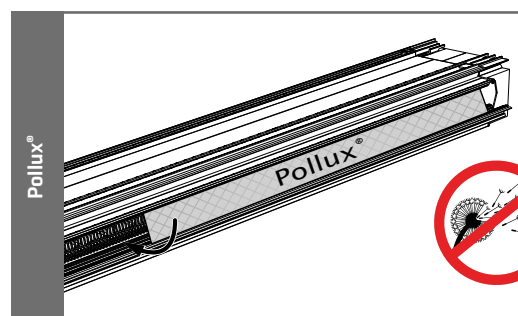

TECHNICAL SPECIFICATIONS

Water- and windtightness is tested accordingly to EN 1027 and EN 1026.

The Renson® products are manufactured according to, complies with and/or has been tested according to:

EN ISO 140-10, EN ISO 717-1, EN 1026, EN 1027, EN 13141-1, EN 12020-2, EN AW 6063 T66, NBN D50-001, EN 10077-2, DIN 16491, prEN 1627, prEN 1628, prEN 1629, prEN 1630.

PATENTED TECHNOLOGY

Most products in our standard range have unique features protected by patents, trademarks and worldwide intellectual property laws. Imitators and copycats will be prosecuted.

DISCLAIMER

Syntha Pulvin is a registered trademark of Valspar Powder Coatings Limited.

Renson® Ventilation nv preserves the right to make technical changes without prior notice.

Technical drawings and section details are not represented at scale 1:1.

Colours, photos, technical drawings and specifications may deviate from the actual product. The latest version of this brochure can be downloaded from www.renson.eu.







Get inspired in our showroom
EXIT5 at Waregem along the E17

E X I T 5

EXPERIENCE, INNOVATION & TECHNOLOGY @ RENSON

WE'D BE HAPPY TO HELP YOU!

Our head office - the elegant building designed by the late architect Jo Crepain, which has been the visiting card of our company for many years now - is now being renovated. The bottom part of the building now has an imposing glass façade. Behind the façade, there is a new 'Customer Centre' with reception rooms for customers, conference rooms, and an auditorium, where large groups of more than 300 people can participate in presentations. In case of smaller groups, this auditorium can also be divided into 3 separate rooms.

The highlight of the project is the new showroom of 1250 m², where professional customers as well as private individuals can be accommodated. Apart from a showroom for Renson's various innovative solutions and concepts, it is planned to make this room a knowledge centre, where customers can walk in and ask questions about ventilation, heating, sun protection, ventilative cooling, acoustics, interior, etc., In short: everything to provide the home with all the necessary comfort. There is also the possibility to view the solutions in practice in show houses located nearby.

For more information about the network of Renson® ambassadors, please visit our website at: www.renson.eu

RENSON®: YOUR PARTNER IN VENTILATION, SUN PROTECTION AND OUTDOOR CONCEPTS

Creating healthy spaces

From 1909, we've been developing energy efficient solutions assuring a healthy and comfortable indoor climate. Our headquarters - built according to the 'Healthy Building Concept' - is a beautiful example portraying our corporate mission.

No speed limit on innovation

A multidisciplinary team of more than 90 R&D employees continually optimize our products and develop new and innovative concepts.

Strong in communication

Contact with the customer is of the utmost importance. A group of 100 in-the-field employees worldwide and a powerful international distribution network are ready to advise you on site. EXIT 5 at Waregem gives you the possibility to experience our products on your own and provides necessary training for installers.

A reliable partner in business

We can guarantee our customers optimal quality and service thanks to our environmentally friendly and modern production sites [with automated powder coating line, anodisation line, uPVC injection molding machinery and mold making shop] covering an area of 95.000 m².





RENSON® Headquarters
Maalbeekstraat 10, IZ 2 Vijverdam, B-8790 Waregem, Belgium
Tel. +32 56 30 30 00
info@renson.eu
www.renson.eu

