

FR 311

SLIDE TYPE:	Regular-Extension Drawer Slide for shelves and drawers
MOUNTING:	Top Mount

WIDTH:	14 mm (0.55 in.)
LOAD CAPACITY:	dynamic up to 45 kg (100 lbs.)



MATERIAL:	steel, white powder coated
------------------	----------------------------

FEATURES	delrin* encased steel ball bearings and solid delrin* rollers
-----------------	---

SPECIFICATIONS:
<ul style="list-style-type: none"> ▶ attaches to the underside of a work surface ▶ the overrun clip in the cabinet profile prevents the drawer or shelf from accidentally disengaging ▶ stop in the cabinet profile

NOTE:
<ul style="list-style-type: none"> ▶ the ideal drawer slide for adding drawers or shelves under an existing work surface

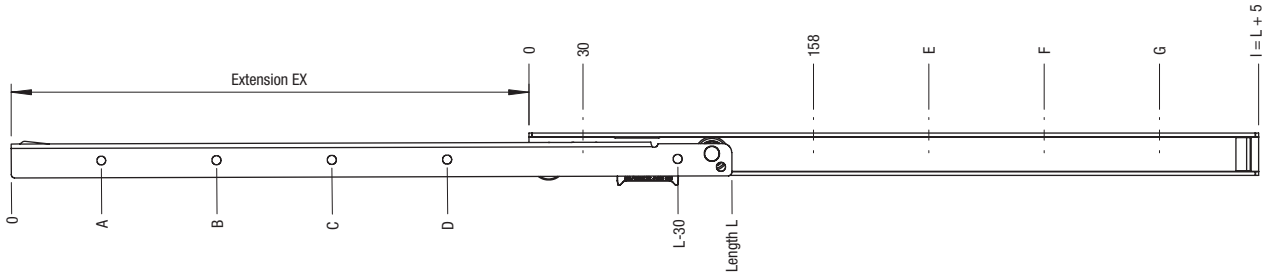
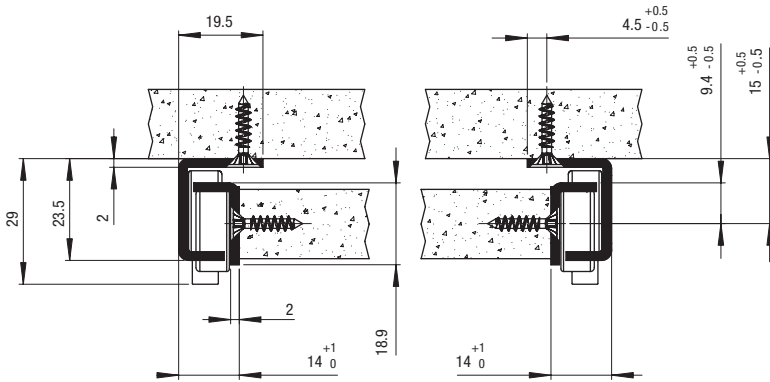

Length L	EX		A		B		C	D		I	E		F	G		Weight		Order No.	Order No.			
	mm	in	mm	in	mm	in		mm	in		mm	in		mm	in	mm	in	kg	lbs	zinc	black	
300	11.81	192	7.56	46	1.81	142	5.59			305	12.01	254	10.00			0.76	1.68	3093	*			
350	13.78	242	9.53	32	1.26	192	7.56			355	13.98	286	11.26			0.87	1.92	3094	80589			
400	15.75	287	11.30	50	1.97	242	9.53			405	15.94	350	13.78			0.97	2.14	3095	89007			
450	17.72	337	13.27	36	1.42	292	11.50			455	17.91	350	13.78			1.10	2.43	3096	80590			
500	19.69	387	15.24	22	0.87	150	5.91	342	13.46	505	19.88	350	13.78	446	17.56	1.22	2.69	3097	80591			
550	21.65	437	17.20	40	1.57	200	7.87	392	15.43	555	21.85	350	13.78	478	18.82	1.34	2.95	3098	80592			
600	23.62	487	19.17	26	1.02	250	9.84	442	17.40	605	23.82	350	13.78	542	21.34	1.45	3.20	3099	*			
650	25.59	537	21.14	76	3.00	300	11.81	492	19.37	655	25.79	350	13.78	542	21.34	*	*	*	*			
700	27.56	577	22.72	30	1.18	158	6.22	350	13.78	542	21.34	705	27.76	350	13.78	542	21.34	670	26.38	*	*	*
750	29.53	627	24.69	16	0.63	176	6.93	400	15.75	592	23.31	755	29.72	350	13.78	542	21.34	702	27.64	*	*	*

Packing Unit: 10 pair per box

* on request

*DuPont (TM) Delrin®