

FR 506.B

SLIDE TYPE:	Regular-Extension, Heavy Duty Slide
MOUNTING:	Bottom Mount

WIDTH:	min. 89 mm (3.50 in.)
LOAD CAPACITY:	dynamic up to 100 kg (225 lbs.)



MATERIAL: steel, powder coated

FEATURES: solid delrin* rollers

- SPECIFICATIONS:**
- ▶ ideally suited for displays, exhibits and store fixtures
 - ▶ absolute lateral stability provided by specially shaped profiles
 - ▶ light, rigid and silent movement via special roller assembly
 - ▶ simple assembly of the pullout unit via countersunk fixing holes for M6 countersunk screws.

- NOTES:**
- ▶ available with top guide on request
 - ▶ special designs available on request

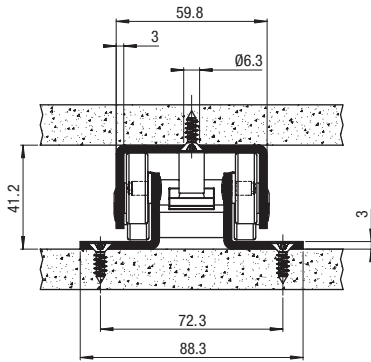
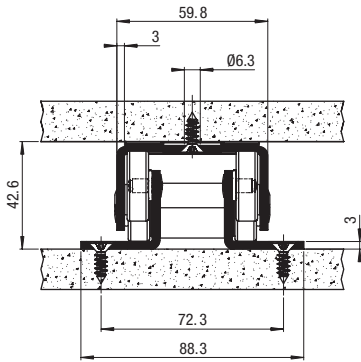

version A with roll-out prevention, lengths: 450-700 mm

version B without roll-out prevention, lengths: 400-1050 mm

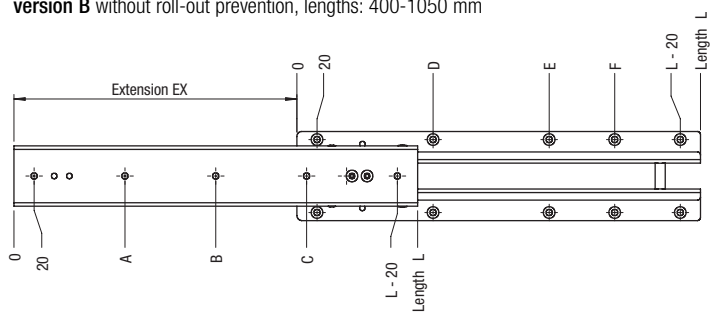
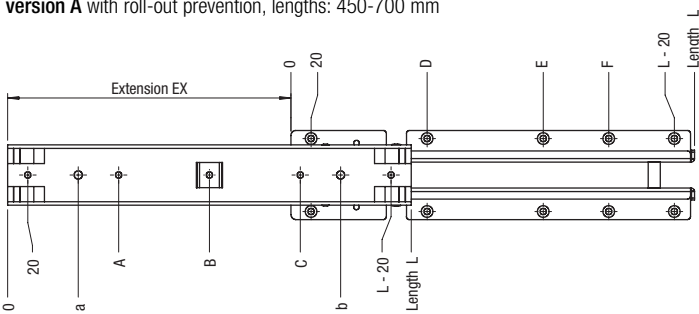

Length L	EX	A	B	C	a	b	D	E	F	Weight per pair	Order No. Version A	Order No. Version B										
mm	in	mm	in	mm	in	mm	in	mm	in	kg												
400	15.75	280	11.02			200	7.87			250	9.84	*	*	1270								
450	17.72	330	12.99			225	8.86	70	2.76	373	14.69	*	1701	1271								
500	19.69	380	14.96			250	9.84	70	2.76	373	14.69	*	1702	*								
550	21.65	430	16.93			275	10.83	70	2.76	373	14.69	*	1703	*								
600	23.62	480	18.90			300	11.81	126	4.96	467	18.39	*	1704	*								
650	25.59	520	20.47	172.5	6.79	325	12.80	477.5	18.80	126	4.96	467	18.39	197.5	7.78	375	14.76	502.5	19.78	*	1705	*
700	27.56	560	22.05	185	7.28	350	13.78	515	20.28	126	4.96	467	18.39	210	8.27	400	15.75	540	21.26	*	1706	1276
750	29.53	600	23.62	197.5	7.76	375	14.76	552.5	21.75					222.5	8.76	425	16.73	577.5	22.74	*	*	*
800	31.50	640	25.20	210	8.27	400	15.75	590	23.23					235	9.25	450	17.72	615	24.21	*	*	1278
850	33.46	680	26.77	222.5	8.76	425	16.73	627.5	24.70					247.5	9.74	475	18.70	652.5	25.69	*	*	*
900	35.43	720	28.35	235	9.25	450	17.72	665	26.18					260	10.24	500	19.69	690	27.17	*	*	*
950	37.40	760	29.92	247.5	9.74	475	18.70	702.5	27.66					272.5	10.73	525	20.67	727.5	28.64	*	*	*
1000	39.37	800	31.50	260	10.24	500	19.69	740	29.13					285	11.22	550	21.65	765	30.12	*	*	*
1050	41.34	840	33.07	272.5	10.73	525	20.67	777.5	30.61					297.5	11.71	575	22.64	802.5	31.59	*	*	*

Packing Unit: on request

* on request

*DuPont (TM) Delrin®

